

# XGT7020-12

## 塔式起重机安装手册

设备型号规格:	QTZ250t.m
总图图号:	XGT7020-12
出厂编号 (PIN 码):	
出厂日期:	年                      月
说明书版本号:	XGT7020-12-20231123
产品说明书是产品的一部分，应始终放在手边以备查阅。 安装、验收、操作、维护保养产品前请仔细阅读该说明书。	

### 版权所有

未经徐工集团的书面许可，不允许对此出版物的任何部分通过任何方法以任何形式进行复制或使用，包括复印、录像、录音或信息贮存及检索系统。

### 注意

永远使用由原始制造商为此机器生产的备件。如果使用了非原始备件，徐工对机器的任何损坏或损失的操作时间不承担责任。

目 录	章 节
前言	
记录、技术参数	第一章
基本安全说明	第二章
技术数据	第三章
总体安装说明	第四章
塔机安装	第五章
安全装置	第六章
起重机使用与操作	第七章
塔机维护保养 故障与排除	第八章
电气设备	第九章
塔机顶升	第十章
附图	第十一章
Content	Chapter
Preface	
Record and Technical parameters	chapter 1
Basic safety illustration	chapter 2
Technical data	chapter 3
General installation instruction	chapter 4
Tower crane installation	chapter 5
Safety device	chapter 6
Tower crane use and operation	chapter 7
Tower crane maintenance, breakdowns and troubleshooting	chapter 8
Electric equipment	chapter 9
Tower crane jacking operation	chapter 10
Appendix	chapter 11

<b>记录、技术参数</b>	<b>第 1 章</b>
<b>Record and technical parameters</b>	<b>Chapter 1</b>
1.1 主页 Homepage	1-3
1.2 说明 statement	1-3
1.3 EC-制造商的声明 EC manufacturer's statement	1-4
1.4 技术参数 parameters	1-5
<b>第二章 —— 基本安全说明</b>	
2.1 警告和符号	2-3
2.2 基本操作与指定用途	2-3
2.3 组织措施	2-4
2.4 人员的选择和资历、基本职责	2-4
2.5 操作阶段的安全说明	2-5
2.6 塔机运输	2-6
2.7 塔机的维护	2-7
2.8 特殊危险警告	2-8
2.9 液压和气动设备	2-8
2.10 噪音	2-9
2.11 油、油脂及其它化学物质	2-9
2.12 计量单位	2-9
<b>Basic safety illustration</b>	<b>Chapter 2</b>
2.1 Symbols and their meanings	2-3
2.2 Basic operations and the development of purpose	2-3
2.3 Organizational measures	2-4
2.4 Selection and qualification of the operator or basic duties	2-4
2.5 Operating Procedures safety instructions	2-5
2.6 Tower crane transportation	2-6
2.7 Tower crane maintenance	2-7
2.8 Special hazard warnings (power)	2-8
2.9 Hydraulic and Pneumatic Equipment	2-8
2.10 Noise	2-9
2.11 Oil, grease and other chemicals	2-9
2.12 Units of measurement	2-9

### 第三章 —— 技术数据

3.1	总则	3-3
3.1.1	塔机部件	3-3
3.1.2	起重臂长度二 / 四倍率载荷图	3-3
3.1.3	塔机配置, 吊钩高度	3-5
3.1.4	不同组合起重臂的平衡重配置	3-9
3.1.5	平衡重制作配筋圈	3-9
3.1.6	钢丝绳规格、结构	3-12
3.1.7	部件运输、吊装单元	3-13
3.2	塔机的基础设置	3-18
3.2.1	塔机的基础载荷	3-18
3.2.2	混凝土基础准备	3-18
3.2.3	混凝土基础配筋图	3-18
3.2.4	接地	3-20
3.2.5	电源	3-21

### Technical data

### Chapter 3

3.1	Overview	3-3
3.1.1	Tower crane parts	3-3
3.1.2	Jib length with 2/4 fall load	3-3
3.1.3	Tower crane configuration and hook height	3-5
3.1.4	Counterweight configuration for different jib length	3-9
3.1.5	Counterweight steel-bar	3-9
3.1.6	Rope specification	3-12
3.1.7	Part transportation and Installation	3-13
3.2	Foundation configuration	3-18
3.2.1	Foundation load	3-18
3.2.2	Concrete foundation preparation	3-18
3.2.3	Concrete foundation steel-bar	3-18
3.2.4	Grounding	3-20
3.2.5	Power supply	3-21

## 第四章 —— 安装总体说明

4.	施工现场的准备	4-3
4.1	准备	4-3
4.2	地面承载力	4-3
4.3	塔机安装区	4-3
4.4	多台塔机的运行	4-3
4.5	施工现场的条件	4-4
4.6	塔机安装队伍与作业人员的条件	4-4
4.7	安全警示标识	4-5

### **Installation Instruction**

### **chapter 4**

4.	Site preparation	4-3
4.1	Preparation	4-3
4.2	Ground endurance	4-3
4.3	Tower crane installation site	4-3
4.4	Operation of multi-crane	4-3
4.5	Situation of construction site	4-4
4.6	Installation team and personnel requirement	4-4
4.7	Safety warning	4-5

## 第五章 —— 塔机安装

5.1	安装注意事项	5-3
5.2	塔机安装	5-8
5.2.1	安装前的准备	5-8
5.2.2	安装步骤	5-10

### **Tower crane installation**

### **Chapter 5**

5.1	Announcements	5-3
5.2	Tower crane installation	5-8
5.2.1	Preparations before installation	5-8
5.2.2	Installation procedures	5-10

## 第六章 —— 安全装置

6.1 起重力矩限制器的调整	6-3
6.2 起重量限制器的调整	6-6
6.3 幅度限位器的调整	6-7
6.4 起升高度限位器的调整	6-7
6.5 变幅制动器	6-8
6.6 回转制动器	6-8
6.7 注意事项	6-9

### **Safety device**

### **Chapter 6**

6.1 Adjustment of lifting moment limiter	6-3
6.2 Adjustment of lifting weight limiter	6-6
6.3 Adjustment of radius stopper	6-7
6.4 Adjustment of lifting height stopper	6-7
6.5 Luffing brake	6-8
6.6 Slewing brake	6-8
6.7 Announcements	6-9

## 第七章 —— 起重机的使用与操作

7.1 一般说明	7-3
7.2 起重机的操作	7-3

### **Tower crane operation**

### **Chapter 7**

7.1 Instruction	7-3
7.2 Crane operation	7-5

## 第八章 —— 起重机的维护与保养 故障与排除

8.1 机械设备维护与保养	8-3
8.2 液压顶升系统的维护与保养	8-3
8.3 金属结构的维护与保养	8-3
8.4 电气系统的维护与保养	8-4
8.5 钢丝绳	8-4
8.6 回转支撑	8-5
8.7 起重机维修时间的规定	8-12
8.8 起重机常见故障与排除	8-14

### **Tower crane repair and maintenance**

### **Chapter 8**

8.1 Mechanical equipment maintenance	8-3
8.2 Hydraulic control system Maintenance	8-3
8.3 Metal structure Maintenance	8-4
8.4 Electric system Maintenance	8-4
8.5 Steel rope	8-4
8.6 Slewing bearing	8-5
8.7 Tower crane Maintenance time	8-12
8.8 Common breakdowns and trouble-shooting	8-14

## 第九章 —— 电气设备

9.1 工作机构	9-3
9.1.1 起升机构	9-3
9.1.2 回转机构	9-4
9.1.3 小车牵引机构	9-5
9.1.4 液压顶升机构	9-5
9.2 电气控制与操纵系统	9-6
9.2.1 起重机的电气操作	9-6
9.2.2 安全装置	9-7
9.2.3 安装注意事项	9-9

### Electric equipment

### Chapter 9

9.1 Working mechanism	9-3
9.1.1 Lifting mechanism	9-3
9.1.2 Slewing mechanism	9-4
9.1.3 Trolley traction mechanism	9-5
9.1.4 Hydraulic jacking mechanism	9-5
9.2 Electric control system	9-6
9.2.1 Electricity operation	9-6
9.2.2 Safety device	9-7
9.2.3 Attention during installation	9-9

## 第十章 —— 塔机顶升

10.1 液压顶升装置	10-3
10.2 顶升数据	10-7

10.3 塔机的平衡	10-7
10.4 标准节的顶升与拆卸	10-7
10.5 塔机准备作业	10-10
10.6 顶升套架的落下	10-18
<b>Jacking and demounting of tower crane</b>	<b>Chapter 10</b>
10.1 Hydraulic jacking device	10-3
10.2 Jacking data	10-7
10.3 Tower crane balance	10-7
10.4 Jacking preparation	10-7
10.5 Jacking procedure	10-10
10.6 Removal of climbing frame	10-18
<b>第十一章 —— 附图</b>	
附录一	11-1
附录二	11-2
<b>Appendix</b>	<b>Chapter 11</b>
Appendix 1	11-1
Appendix 2	11-2
<b>第十二章 —— 首次安装及性能试验记录表</b>	<b>12-1</b>
<b>Chapter 12 Initial installation and performance testing record</b>	<b>12-22</b>

# 前 言

## Foreword

尊敬的用户：

您好！

感谢您选用徐州建机工程机械有限公司生产的 XGT7020-12 塔式起重机。在安装和使用 XGT7020-12 塔机之前，请仔细阅读本说明书的有关内容，如果您在安装使用过程中遇到问题，请及时与我公司联系。

本说明书中介绍了 XGT7020-12 塔机各部件结构，安装、操作、维护等用户使用所需资料。在您使用徐州建机生产的 XGT7020-12 塔机之前，请认真阅读该说明书！操作者要特别注意说明书中标注“注意”、“警告”、“危险”的内容。



**警告** 只有经过严格培训并经考试合格取得相关资质证书的专业操作人员能操作该塔机！

必须严格执行有关的操作说明、相关的法规和行政指令。忽视任何有关的要求都有可能导致事故和伤害！

在操作塔机前，应了解使用说明书中规定的说明和程序。若有疑问，可求助应急技术服务。



**注意** 安装在塔机上的所有安全装置，必须定期检查确保使其处于良好的工作状态。当塔机出现故障或已经不能保证可靠使用时，应立即停止使用该塔机！

本说明书版权属于徐州建机工程机械有限公司，徐工塔机保留更改的权利，如有变更，届时恕不另行通知。本说明书中可能部分图文与实物略有不符，但是不影响您正常使用，产品状态以实物为准。

**Dear users:**

Thank you for choosing XGT7020-12 tower crane of Xuzhou Construction Machinery Co., Ltd. Before installing and using XGT7020-12 tower crane, please read the contents of this instruction. If you encounter any problems in the installation process, please contact our company timely.

This instruction introduces each part of the XGT7020-12 tower crane, as well as the information users require, such as installation, operation, maintenance information and so on. Before you use the XGT7020-12 tower crane of Xuzhou Construction Machinery Engineering Machinery Co., Ltd. please read the instructions carefully. Pay particular

attention to the mark of "Caution", "Warning", and "Danger" in this instruction.



**Operators must be adequately trained and qualified to use the machine!**

Strictly implement the relevant instructions, regulations and administrative instructions. Any ignorance to the relevant requirements likely leads to accidents and injuries!

Before operating the tower crane, you should understand the instructions and procedures specified in the instructions. If there are any doubts, you should seek help from the emergency technical services.



**All safety devices installed on the tower must be checked regularly to ensure that it is in good working condition. When the tower fails or cannot ensure reliable function, you should immediately stop using the tower crane!**

The instruction (Version code: XCMG-TC-20170101) copyright belongs to Xuzhou Construction Machinery Co., Ltd.(i.e. Tower Crane company of XCMG). Our company reserves the right to change, and, are subject to change without notice then. There may be some difference between the description and the physical machine and that would not affect your normal use of the product. The product state depends on the physical machine.

**时刻谨记：规范操作，安全第一！**

**Remember: keep standard operation and safety first!**

公司地址：徐州市经济技术开发区徐海路 80 号


公司电话：0516—83058265


Company Address: No. 80 Xuhai Road, Economic and Technological Development Zone, Xuzhou, Jiangsu Province, China


Tel: 0516-83058265


### 符号及其含义:

- 在操作塔机前, 应了解使用说明书中规定的说明和程序。若有疑问, 可求助应急技术服务。

 ——警告词“危险”表示即将发生的危险状况。如果不能避免, 将导致死亡或重伤。


 ——警告词“警告”表示潜在的危险状况。如果不能避免, 可能会导致死亡或重伤。


 ——警告词“注意”表示潜在的危险情况。如果不能避免, 可能导致轻伤或者中度等程度的伤害。


 ——需要根据要求进行相关检查

### Symbols and their meanings:

Before operating the tower crane, you should understand the instructions and procedures specified in the instructions. If in doubt, seek help emergency Technical services.

 - "Danger" indicates imminent dangerous situation. If not avoided, it will result in death or serious injury.

 - "Warning" indicates a potentially dangerous situation. If not avoided, it could result in death or serious injury.

 - "Caution" indicates a potentially dangerous situation. If not avoided, it could result in minor or moderate degree injuries.

 - Needs to be checked in accordance with the relevant requirements

徐工塔机系列产品为满足市场及客户的增值需求将不断优化和完善，随机文件也会同步更新。该编号的随机文件与该编号的塔机一一对应，客户在安装使用的过程中如需进一步了解相关内容，敬请与本公司联系。

XCMG Tower crane products will continue to optimize and improve to meet market demand and customer's requirements, the attached file will be synchronized. The attached file is correspondent to the same number of tower crane. If any customers want more information related to the content in the installation process, please contact us.

<b>记录</b>	<b>技术参数</b>	<b>第一章</b>
1.1	主页	1-3
1.2	说明	1-3
1.3	EC-制造商的声明	1-4
1.4	技术参数	1-5
<b>Record and technical parameters</b>		<b>Chapter 1</b>
1.1	Homepage	1-3
1.2	Statement	1-3
1.3	EC manufacturer's statement	1-4
1.4	Parameters	1-5



## 1.1 主页

制造商	徐州建机工程机械有限公司
型号	XGT7020-12
生产编号	
制造年度	
起重机型式:	空中水平臂塔式起重机
起重机用途:	物件吊运
工作类型:	固定控制

### 1.1 Homepage

Manufacturer: Xuzhou Construction Machinery Co., Ltd.

Mode: XGT7020-12

Production Numbers:

Manufacture Year: 2016

Crane Type: Air horizontal arm tower crane

Crane use: lifting objects

Operation type: Fixed Control

## 1.2 说明

1.2.1 在检查塔式起重机（以下简称塔机）时，应遵守以下事项：

- 国家塔机相关的安全规定
- 塔机使用的标准与指南
- 保持塔机测试记录的完整性（所有页码齐全），塔机测试记录应由有资质的技术人员/专家工程师进行检查、登录（见 ISO 9972-1）。
- 定期检查所用塔机的测试记录簿。记录的空白页可复制。

### 1.2.2 检查

1.2.2.1 塔机在首次使用前或大修后应进行检查。

1.2.2.2 用户应保证塔机在首次使用前或大修后返回使用前，应将所有运行机构由资质的技术人员/专家工程师进行测试。首次使用前的概念同样适用于载荷能力超过 1000 公斤的塔机。

1.2.2.3 新塔机首次使用前应按 1.2.2.2 要求进行测试，在确保塔机正确组装的条件下，准备进行调试工作。

1.2.2.4 对于已经准备进行调试的新塔机，且附带有类型测试证明的，该塔机在首次使用前不必按 1.2.2.2 要求进行测试。

### 1.2.3 定期检查

1.2.3.1 用户应保证塔机在按其正常的工作条件以及使用地区的具体情况，制定适当时间的检查间隔（一年至少一次），届时应由有资质的技术人员/专家工程师对塔机进行必要的检查。用户还应保证塔机在安装或转变为新组合机型都应有资质的技术人员/专家工程师进行检查。

1.2.3.2 用户应保证：

- a) 动力驱动固定式塔机；
- b) 动力驱动行走式塔机；
- c) 动力驱动动臂式塔机（包括改变其工作位置）；
- d) 车载快装式塔机。

至少每隔 4 年由专家工程师进行一次检查。

1.2.3.3 用户应保证在第 1.2.3.2 条规定外的其他动力驱动塔机应由专家工程师在第 18 年时进行一次检查，而后每年检查一起。

1.2.3.4 第 1.2.3.2 条不适用于永久安装的车载快装式塔机。

1.2.3.5 塔机测试记录簿

用户应保证：将按以上要求进行检测，并将结果记入测试记录簿中。

附注：专家工程师

他们应该是政府部门管辖或授权的技术检验部门成员或行业保证部门制定的人员。上述检查不包括其它部门要求的检查，例如：道路交通保准等。

## 1.2 Statement

1.2.1 In the examination of tower cranes (hereinafter referred to as tower crane), you should observe the following:

- Associated national tower crane safety requirements
- Standards and guidelines tower crane used
- Maintain the integrity of the tower crane test records (all pages complete).  
The tower crane test records shall be checked and logged by a qualified technician / specialist engineers (see ISO 9972-1).
- Regular inspection for test log book of tower crane used is needed. Blank pages can be copied.

### 1.2.2 Inspection

1.2.2.1 Tower machine should be checked before first use or after the overhaul.

1.2.2.2 The user should ensure that all the tower crane mechanisms, before first use or after a major overhaul to return before use, should all run by a qualified technician / expert engineers for testing. Before the first use the concept applies equally to the load capacity of tower crane more than 4000 kg.

1.2.2.3 New tower crane shall be tested as 1.2.2.2 required before initial use, and be ready for

commissioning ensuring proper assembly of the tower crane condition.

**1.2.2.4** For new tower crane ready for commissioning with the type of test to prove that the tower before the first use does not have to be tested according to the requirements 1.2.2.2.

### **1.2.3 Regular check**

**1.2.3.1** The user should ensure that the tower crane is in its normal working conditions and the use of the specific circumstances of the region, and develop the appropriate time inspection intervals (at least once a year), then checks by a qualified technician / specialist engineer on the tower machine. Users should also ensure that the tower crane is installed or converted into new combinations models when there are qualified technician / specialist engineers checked.

**1.2.3.2** Users shall ensure that:

- a) power-driven fixed tower crane;
- b) power-driven traveling tower crane;
- c) power-driven luffing tower crane (including changing its working position);
- d) Automotive fast-loading crane.

Inspect by an expert engineer at least 4 years as an interval.

**1.2.3.3** The user should ensure that the other power-driven tower crane shall be checked provisions in section 1.2.3.2 of by expert engineers in the first 18 years of the time, and then check it each year.

**1.2.3.4** Section 1.2.3.2 does not apply to the permanently installed fast-mounted crane.

### **1.2.3.5 Tower crane test logbook**

Users should ensure: conduct test according to the above requirements, and the results shall be recorded in the test logbook.

Note: Expert Engineer

They should be under the jurisdiction of the government departments or officers authorized by technical inspection department to ensure that members or industry sectors to develop. The examination does not include other sectors required to check, for example: road traffic guarantee and so on.

## **1.3 EC-制造商的声音**

### 制造商的声明

我们                      徐州建机工程机械有限公司  
                                 徐州经济技术开发区徐海路 80 号  
                                 中国

郑重声明：以下描述部件的设计，在执行供货中，确定为塔式起重机安装。但在未

确定其部件严格按照使用说明书中的规定进行安装前，不得用于塔式起重机。

### 1.3 EC manufacturer's statement

#### Manufacturer's Declaration

We Xuzhou Construction Machinery Co., Ltd.

No. 80, Xuhai Road, Xuzhou Economic and Technological Development Zone

China

**Declaration:** The following descript components design in the implementation of supply, identified as tower crane installation. However, the tower crane should not be used before confirming its components installed in strict accordance with the provisions of the instruction manual installation.

机器/机器部件的名称 Name of machines / machine parts	空中水平臂塔式起重机 Air horizontal arm tower crane
制造商/型号 Manufacturer / Model	XGT7020-12
系列号 Series No.	
制造年度 Manufacture Year	2016
使用的相关标准 Related standards	GB5144-2006 塔式起重机安全规程 GB/T13752-92 塔式起重机设计规范 GB/T5031-2008 塔式起重机 GB/T3811-2008 起重机设计规范 GB5144-2006 Tower Crane Safety Regulations GB/T13752-92 Tower Crane Design Specification GB/T5031-2008 Tower Crane GB/T3811-2008 Crane Design Specifications

### 1.4 技术参数

#### 1.4 Technical parameters

机构工作级别 Mechanism working level	起升机构 Lifting mechanism	M5
	回转机构 Slewing mechanism	M5
	牵引机构 Traction mechanism	M4

起升高度 m Lifting height		倍率 Fall	独立固定 Independent		附着 Attached		
		$\alpha=2$	60		240		
		$\alpha=4$	60		120		
最大起重量 t Max load capacity		12					
幅度 m		最大幅度 Maximum			70		
		最小幅度 Minimum			3		
起升机构 Lifting mechanism	倍率 Fall	a=2			a=4		
	速度 m/min Speed	0~45	0~68	0~92	0~22.5	0~34	0~46
	起重量 t Lifting weight	6.0	4.2	2.1	12	8.4	4.2
	容绳量 m Rope capacity	695					
	电机型号 Motor type YZP2 250M1-4B 30L 55kW						
回转机构 Slewing mechanism		转速 Rotating speed	电机型号 Motor type		功率 Power		
		0~0.8 r/min	YTRVFW132M2-4F1		2×7.5kW		
小车牵引机构 Trolley traction mechanism		速度 Speed	电机型号 Motor type		功率 Power		
		0~65m/min	YTDVF132M1-4C		5.5 kW		
顶升机构 Jacking mechanism		0.5 m/min	Y160M-4	11 kW	1460 r/min		
		工作压力 Working pressure	36 MPa				
平衡重 Counterweight		臂长 m Jib length		重量 t Weight	臂长 m Jib length	重量 t Weight	
		30		10.8	55	19	
		35		12.4	60	19.5	
		40		14.4	65	21	
		45		16.4	70	21	
		50		17.9			
总功率 Total power		75.5kW (不包括顶升) (excluding the jacking system)					
工作温度 Ambient temperature		-20 °C ~ +40°C					
主电缆 The main cable		YC3×35+2×10					

<b>基本安全说明</b>	<b>第二章</b>
2.1 警示和符号	2-3
2.2 基本操作与指定用途	2-3
2.3 组织措施	2-4
2.4 人员的选择和资历/基本职责	2-4
2.5 操作阶段的安全说明	2-5
2.6 塔机运输	2-6
2.7 塔机的维护	2-7
2.8 特殊危险警告	2-8
2.9 液压和气动设备	2-8
2.10 噪音	2-9
2.11 油、油脂及其它化学物质	2-9
2.12 计量单位	2-9

<b>Basic safety illustration</b>	<b>Chapter 2</b>
2.1 Symbols and their meanings	2-3
2.2 Basic operations and the development of purpose	2-3
2.3 Organizational measures	2-4
2.4 Selection and qualification of the operator or basic duties	2-4
2.5 Operating Procedures safety instructions	2-5
2.6 Tower crane transportation	2-6
2.7 Tower crane maintenance	2-7
2.8 Special hazard warnings (power)	2-8
2.9 Hydraulic and Pneumatic Equipment	2-8
2.10 Noise	2-9
2.11 Oil, grease and other chemicals	2-9
2.12 Units of measurement	2-9

## 2.1 警示和符号

- 在操作塔机前，应了解使用说明书中规定的说明和程序。若有疑问，可求助应急技术服务。
- 徐州建机工程机械有限公司保留对塔机技术参数的改动或随时改动塔机的权利，恕不另行通知。

**注意：使用说明书中的下列标记和符号用于指明特殊重要说明。**



——警告词“危险”表示即将发生的危险状况。如果不能避免，将导致死亡或重伤。



——警告词“警告”表示潜在的危险状况。如果不能避免，可能会导致死亡或重伤。



——警告词“注意”表示潜在的危险情况。如果不能避免，可能导致轻伤或者中度等程度的伤害。



——需要根据要求进行相关检查

### Symbols and their meanings:

Before operating the tower crane, you should understand the instructions and procedures specified in the instructions. If in doubt, seek help emergency Technical services.

Xuzhou Construction Machinery Construction Machinery Co., Ltd. conserves the right to alter the technical parameters of tower crane, without notice.

Note: Use the following signs and symbols in the instructions to indicate special importance instructions.



——“Danger” indicates a hazardous condition that is about to happen. In the case of failure to avoid, death or severe injuries will be caused.



——“Warning” indicates a potential dangerous condition. In the case of failure to avoid, death or severe injuries may be caused.



——“Caution” indicates a potential dangerous condition. In the case of failure to avoid, minor or moderate injuries may be caused.



——Inspect according to specific requirements.

## 塔机的使用

- MST330 塔机是上回转的塔机。它专门为起重而设计，用户应按照使用说明书中描述和规定进行水平起落负载。
- 使用说明书中描述塔机的使用和配置是制造商唯一认可的。塔机只能按此说明书的规定使用。
- 对于钢结构和机械部件应予以适当维护，使之整个系统工作良好，以确保塔机的预期用途。

## Tower crane use

- MST330 is upper-slewing tower crane, which is designed for lifting. User can operate it to lift load according to the Instruction.
- The described operation and configuration of tower crane is recognized only by manufacturer. And the tower crane shall be operated as the Instruction.
- To achieve the expected use, it needs to do some proper maintenance to steel structure and mechanical parts.
- 

## 2.2 基本操作与制定用途

**2.2.1** 尽管塔机已按照最新标准和认可的安全规程制造，然而它的使用仍会对使用者或者第三方身体和生命构成危害，或者造成机器及其它物质财产损失。

**2.2.2** 塔机只能在技术完善的条件下按其指定用途和使用说明书的规定使用，并只能由完全了解并掌握操作且具有资质的人员进行操作。因此，任何无序功能，尤其影响安全的须立即纠正。

**2.2.3** 塔机是专门为提升、降落和由起重吊钩自由悬挂载荷进行水平运输而设计的，载荷只能从坚固的基础/地面上吊起。

**2.2.4** 在指定用途限制之内操作塔机要遵守使用说明书的规定，并应遵守检查和维护指南。

**2.2.5** 作为特殊的安全警告/具体的安全警告及与产品相关的/主要复制资料，用户相关部门/人员有权对操作人员予以指导。

### **2.2 Basic operations and the development of purpose**

**2.2.1** Although the tower has been approved in accordance with the latest standards and safety regulations manufacturing, but its use still may impose danger on the user or a third-party body or cause damage to property, plant and other substances.

**2.2.2** The tower crane can only specify the purpose and use manual techniques in accordance with the provisions used in perfect condition. And only fully understanding and mastering the operation and having qualified, are personnel allowed to operate tower crane. Therefore, any disordered function, especially affecting safety must be corrected immediately.

**2.2.3** The tower is dedicated to the promotion, landing and lifting hooks freely suspended loads from the horizontal transport and design, the load can only be lifted from the solid foundation / floor.

**2.2.4** Operation within the specified restrictions are allowed for the use of the tower, complying with instructions for the confidential and shall comply with the inspection and maintenance guidelines.

**2.2.5** As a special safety warning / specific safety warnings and product-related / main copy data, user departments / personnel shall be entitled to the operator guidance.

## **2.3 组织措施**

**2.3.1** 在塔机使用地点操作人员必须备有使用说明书（放在为此提供的工具室或工具箱内）。

**2.3.2** 除使用说明书外，凡涉及到有害物质的处理、个人防护用品的发放/佩带以及相关的交通法规等其它通用、强制性法律、法规，操作人员应接受事故防范和环境保护有关部门的监督、指导。

**2.3.3** 使用说明书必须按照包括监督、指导相关部门所涉及的职责，例如，工作组织、工作顺序或工作委托人的说明执行。

**2.3.4** 塔机操作人员必须在工作之前认真阅读了解使用说明书，特别是有关安全的章节。对于初次上机的操作人员尤为重要。

**2.3.5** 用户的相关部门应经常简化操作人员是否按照使用说明书进行工作，并注重危险和安全因素。

**2.3.6** 操作人员应遵守塔机上所标的所有安全说明和警告标志。

**2.3.7** 塔机在运行期间其操作上出现与安全有关的违章操作，操作人员应立即停机并将故障报告给主管部门/人。

**2.3.8** 未经供货商/制造商的同意，不得进行塔机安全的任何改动、添加或变换。不得

进行塔机安全装置的安装与调整及承载件的焊接作业。

**2.3.9** 塔机的备品配件必须符合供货商/制造商所规定的技术要求，应使用原设备制造商的备品配件。用户在安装备品配件之前应对备品配件样本所规定的数据进行比较、鉴定。

**2.3.10** 塔机的液压软管和气动管路，应按使用说明书的规定或适当的时间间隔进行更换。

**2.3.11** 日常检查检验的时间间隔应按照使用说明书的规定执行。

**2.3.12** 用户应为塔机的维修保养设置必要的设备工具和车间场地。

### **2.3 Organizational measures**

**2.3.1** Place tower crane operator must have a manual (or toolbox in the tool room provided for this purpose).

**2.3.2** In addition to the instruction manual, when it comes to handling hazardous materials, personal protective equipment issued / Perry Other universal, mandatory laws, regulations, associated traffic regulations, operating personnel should be subject to the supervision of environmental protection departments to prevent accidents and guidance.

**2.3.3** Instructions must follow, including supervision and guidance responsibilities related departments involved, for example, work organization, work order or job description of the principal executive.

**2.3.4** Tower crane operator must carefully read the instruction manual before work, especially security-related chapters. Particularly it is importantly for machine operator at the first time.

**2.3.5** Users should always check if the operator is operating in accordance with the manual, and focus on the risk and safety factors.

**2.3.6** The operator shall comply with all the safety instructions and warning signs on the tower crane.

**2.3.7** When tower crane appears safety-related illegal operation during operation, the operator should immediately stop and report the fault to the competent department or person.

**2.3.8** Without the supplier or manufacturer permission, you shall not carry out any changes to the tower crane, adding or changing. Don't conduct any installation and adjustment of safety device, or welding operations.

**2.3.9** Tower crane spare parts must meet the technical requirements or specified by the

manufacturer or supplier. You should use the original equipment manufacturers' spare parts. User before installing spare parts should do the comparison and identification for the sample data provided.

Hydraulic hoses and pneumatic lines 2.3.10 tower crane, or should the instructions of the appropriate intervals for replacement.

**2.3.11** Routine examination and inspection intervals should be performed in accordance with the instructions for use.

**2.3.12** The user should set the necessary tools and equipment for the repair and maintenance of tower crane.

## **2.4 操作人员的选择和资历/基本职责**

**2.4.1** 塔机的操作人员应遵守最低法定年龄限制，且具有一定的文化水准和身体素质。

**2.4.2** 塔机的操作人员应选择经过政府相关部门培训并使之合格的人员，并掌握塔机的转移运输、安装拆卸、使用操作、维护保养等具体职责。

**2.4.3** 用户应授权有资质的人员操作塔机。

**2.4.4** 用户应制定塔机的操作规范，给予操作人员有拒绝接受第三方违反安全指令的权利。同时督促遵守塔机运输途中的交通法规。

**2.4.5** 塔机严禁无资质人员操作。培训、实习人员应在专业人员监督指导下方能操作塔机。

**2.4.6** 处理塔机的电气系统，应由有资质的电气工作人员或专业人员按电气工程规则与规程进行作业。

**2.4.7** 处理塔机的机械部分（如变速箱、底盘、制动系统等），应由有资质的机械工作人员或专业人员进行作业。

**2.4.8** 处理塔机的液压系统，应由有资质的液压和气动专业人员进行作业。

## **2.4 Selection and qualification of the operator or basic duties**

**2.4.1** Tower crane operator shall comply with the minimum legal age limit, and has a certain level of cultural and physical quality.

**2.4.2** Tower crane operator should be selected by the relevant government departments through training, mastering tower crane transportation, installation and removal, operation, maintenance and other specific duties.

**2.4.3** Users should authorize qualified personnel to operate the tower crane.

**2.4.4** Users should develop practices tower, giving the operator the right to refuse violation of safety instructions of a third party. Be compliance with traffic laws while in transition of tower crane.

**2.4.5** It is strictly prohibited without qualified personnel to operate tower crane. Trainee or interns should be under the supervision and guidance of professionals to operate tower crane.

**2.4.6** Dealing with tower crane electrical system shall be done by qualified or professional staff as electrical engineering rules and procedures to perform operations.

**2.4.7** Dealing with tower crane mechanical parts (such as the gearbox, chassis, braking system, etc.), shall be done by qualified or professional staff for mechanical operations.

**2.4.8** Dealing with tower crane hydraulic system shall be done by qualified or professional staff as electrical engineering rules and procedures to perform operations.

## **2.5 操作程序的安全说明**

**2.5.1** 塔机的操作除按使用说明书的规定执行外，还应遵塔机使用地区的塔机使用相关的法律法规。

**2.5.2** 塔机运行前，操作人员应了解塔机施工现场的工作环境(包括：如作业和回转范围内障碍物、土层的承载能力以及将塔机施工现场与公共用地分开需要的隔离物等)。

**2.5.3** 塔机施工现场应采取必要的预防措施，以保证塔机能在安全可靠的状态下使用。

**2.5.4** 塔机在调试或运行中，应确信无人处于危险中。

**2.5.5** 塔机在运行前，应确保所有保护和限位装置调试验收合格后，方可操作塔机。

**2.5.6** 严禁以任何不利于安全的方式操作运行塔机。

**2.5.7** 塔机在启动和关闭运行中，操作人员应始终注意观察指示器。

**2.5.8** 塔机在运行时，操作人员应始终拥有良好的工作环境和载荷视野。载荷视野条件差或暗，现场必须提供足够的照明。

**2.5.9** 塔机在运行时，当起重吊钩悬挂载荷时，不得关闭塔机的控制系统。

**2.5.10** 塔机的现场指挥必须是有资质的人员担任。现场的吊运指挥应在操作者视听范围内。

**2.5.11** 每个工作班次应至少检查一次塔机将发生的缺陷与损坏。一旦检查确认所发生的

缺陷与损坏(包括作业状态变化), 应立即向主管部门 / 人员报告。必要时, 立即停机。

## **2.5 Operating Procedures safety instructions**

**2.5.1** Operate tower crane as the requirements on Instruction, but also as the local relevant laws and regulations.

**2.5.2** Before running the tower crane, operator should be aware of the work environment of the construction site (including: the scope of the job and slewing obstacles, soil bearing capacity and separation between construction site and public space etc.).

**2.5.3** In tower construction site you should take the necessary precautions to ensure that the tower is used in safe and reliable state.

**2.5.4** When tower crane is in debugging or running, make sure no one is in danger.

**2.5.5** Before tower before running, you should ensure that all protection and safety limit device is debugged to be qualified.

**2.5.6** It is prohibited to run tower crane in any detrimental way.

**2.5.7** Tower crane at startup and shutdown operation, the operator should always observe the indicator.

**2.5.8** Tower crane at runtime, the operator should always have a good working environment and vision. If poor vision or dark site, you must provide adequate lighting.

**2.5.9** At runtime of tower crane, when the lifting hooks suspended with load, the control system may not be shut down.

**2.5.10** Tower crane field command must be a qualified officer. Lifting commanding site should be within visual range of the operator.

**2.5.11** At each work shift tower crane should be checked at least once for defects and damage. Once confirmed defects and damage (including job status changes), you should be reported to the competent authorities or personnel immediately. If necessary, shut down the tower crane immediately.

**2.5.12** 塔机不得带故障运行。

**2.5.13** 塔机的随机工具以及松散物体应放置于安全地方。

**2.5.14** 塔机所有的手柄、挡位、扶手、平台、上下爬梯应保持干净, 不得有油污、水等

污染物污染。

**2.5.15** 塔机的工作状态下风速应在 12~13 米 / 秒(风力 6 级)。当最大风速超过 20 米 / 秒时(相当于风力 8 级), 塔机应停工作。

**2.5.16** 当离开塔机时, 应按使用说明书的规定, 关闭电源、做好一切保护防范的停机措施。必要时应固定好塔身, 以防意外发生。

**2.5.17** 任何其它或强行的使用, 比如:

- 起吊未放稳的载荷;
- 未自由悬挂的载荷作水平移动;
- 起吊固定于地面下的载荷;
- 载荷旋转或振动;
- 超出规定载荷额定值的任何负载;
- 斜拉;
- 载荷上或载荷固定装置上载人等。

都是不可取的, 并应禁止。

**2.5.12** Tower crane shall not run with failure.

**2.5.13** Tower crane attached tools and loose objects should be placed in a safe place.

**2.5.14** All the handles, gear, handrails, platforms, ladders should be kept clean from top to bottom, without oil, water and other contaminants.

**2.5.15** Wind speed should be under 12 to 13 m / s (wind 6) when tower crane is in working condition. When the maximum wind speed exceeds 20 m / sec (equivalent to wind 8), the tower crane should stop working.

**2.5.16** When leaving the tower crane, you should turn off the power and do every shutdown protection measures according to the provisions of the specification. If necessary, fix tower to prevent accidents. **2.5.17** Any other operation, such as:

- Hoist unsteady loads;
- Not freely suspended loads for horizontal movement;
- Lifting fixed load underground;
- Load rotation or vibration;
- Lifting load exceeding the rated load;
- Stayed;

- $\lambda$  Carry people on load.

All are undesirable and should be prohibited.

## 2.6 塔机运输

- 2.6.1** 塔机运输前, 应检查塔机运输装置(如: 自行安装的起重机或运输车辆)的安全性, 例如: 轴、制动器、转向器、信号和照明系统, 应处于良好工作条件。
- 2.6.2** 塔机运输之前, 应检查辅助工具安全放置以及所有散件固定可靠。
- 2.6.3** 塔机运输时, 行驶在任何公路、铁路线或地方上, 应事先保证塔机符合道路交通车辆使用管理规定, 并注意关注法规所规定的有效路况。
- 2.6.4** 塔机运输时, 当行驶通过下道、桥梁、隧道或架空电线下面时, 应保证有足够高度的空间。
- 2.6.5** 对于有悬挂机构的运输装置, 在运输时不可横向定位行驶。道路上的坑、坡应密切关注, 确保路况安全。

## 2.6 Tower crane transportation

- 2.6.1** Before transportation, you should check the tower crane transport devices (e.g.: self-mounted crane or transport vehicles) security, such as: axle, brakes, steering, signaling and lighting systems, should be in good working condition.
- 2.6.2** Before transportation, safety aids should be checked as well as all parts to be fixed and reliable.
- 2.6.3** In transportation, driving on any road, railway line or place, you should firstly ensure that the tower crane vehicles comply with road traffic regulations, and pay attention to valid road regulations.
- 2.6.4** In transportation when traveling through the lower road, bridge, and tunnel or below overhead wires, you should ensure that there is sufficient height space.
- 2.6.5** For transportation device with suspension mechanism, cannot be positioned laterally in transporting. You should pay close attention to pit on road and the slope to ensure safety.

## 2.7 塔机的维护

- 2.7.1** 工作期间, 应正确处置有关塔机使用的维修零配件和易损件更换相关特殊工作。
- 2.7.2** 遵守使用说明中规定的调整、维护和检查作业(包括零件和易损件的更换)。这

些作业应由有资质的技术人员进行操作。

- 2.7.3 进行特殊操作和维护作业之前，应对操作人员进行塔机状况的必要介绍，并指派专人督促作业。
- 2.7.4 在涉及操作塔机的相关检查、维修等的具体作业时，特别是塔机的安全限位装置的调整或变动更应要遵循使用说明书的规定，启动和关闭塔机相关程序。
- 2.7.5 在操作塔机的相关检查、维修时，应保证检查、维修区域的安全。
- 2.7.6 塔机在完全关闭状态下进行修理和维护作业，应锁定主要控制器件并卸下启动钥匙，在电源箱上挂上警告标志。并加以安全保护监督，以防意外启动电源。
- 2.7.7 在进行塔机高空组装、维修作业时，应使用攀爬塔机的专用爬梯和作业平台，不得在塔机的塔身上攀爬。
- 2.7.8 塔机在组装、维修作业中必须拆除其安全装置的，则工作结束后应马上恢复该装置，并应重新检查、调试。
- 2.7.9 在塔机更换或拆卸大型部件或组件时，应使用符合载荷能力、技术完备良好的起重设备进行吊装。
- 2.7.10 悬吊载荷下不得进行作业或站人。

## **2.7 Tower crane maintenance**

2.7.1 During the work, you should use the proper disposal of the tower crane parts and maintenance-related replacement of wearing parts.

2.7.2 Comply with the instructions to adjust the prescribed maintenance and inspection operations (including replacement parts and wearing parts). These operations should be carried out by qualified technician to operators.

2.7.3 Prior to the operation and maintenance, it is necessary to introduce tower to special operations personnel about operating conditions and assign someone to supervise operations.

2.7.4 when it comes to operating the related inspection maintenance and other specific jobs for tower crane, especially adjustments or changes in the safety limit device of the tower crane, you should follow the provisions in instructions related to the startup and shutdown procedures.

2.7.5 Operating the tower crane related inspection and maintenance, you should ensure the safety of the inspection and maintenance area.

2.7.6 For repair and maintenance work of tower crane in the fully closed state, the primary

control device should be locked and remove the ignition key, put up warning signs on the power box. And security oversight is necessary to prevent accidental activation power.

**2.7.7** Conducting aerial tower crane assembly or maintenance operations, you should use a dedicated ladder and platforms for climbing tower, not be climbing on tower crane body.

**2.7.8** Tower crane in assembly and maintenance operations, its safety devices must be removed and should be resumed immediately after that, and should be re-checked and commissioning.

**2.7.9** When the replacement or removal of large parts or components for tower crane, you should use complete lifting equipment in accordance with the load capacity and technology.

**2.7.10** Any one standing or operation shall not be allowed under suspended load.

**2.7.11** 维修期间，要做好各连接件的紧固工作。

**2.7.12** 用水、蒸汽喷射(高压清洗)或洗涤剂清洗塔机时，为了维护功能和安全起见，所有开孔应盖好或用胶带封好，以防止水、蒸汽或洗涤剂渗入。特别注意电机和电器箱、限位开关和回转支承的进水或渗入。

**2.7.13** 清洗完后，取下所有为此所用的盖和胶带。

**2.7.14** 维修期间应修整塔机的所有缺陷。检查所有安全装置是否处于良好工状态。检查液压和气动管路是否泄漏。

**2.7.15** 清洗之后，应检查塔机所有电气、液压和气动管线有否擦伤和损坏。

**2.7.16** 保证所有损耗件和更换件安全地和以最小的环境影响方式处置。

**2.7.11** During maintenance period, do the work of tightening connector.

**2.7.12** Using water, steam jet (high pressure cleaning) or detergents to clean the tower, in order to maintain the functionality and safety reasons, all openings should be covered or sealed with tape to prevent water, steam or detergent infiltration. Special attention to water infiltration into motors and electrical boxes, limit switches and slewing bearing.

**2.7.13** After cleaning, remove all used cap and tape to this end.

**2.7.14** During maintenance period all defects of tower crane should be trimmed. Check that all safety devices are in good working condition. Check the hydraulic and pneumatic pipe leaks.

**2.7.15** After cleaning, check whether all tower crane electrical, hydraulic and pneumatic

pipeline has scratches and damage or not.

**2.7.16** Ensure that all wearing parts and replacement are disposed safely and with minimal environmental impact.

## **2.8 特殊危险的警告(电源)**

**2.8.1** 只能使用具有规定电流额定值的原装熔断器。

**2.8.2** 当作业靠近高空电线时，高空电线与塔机应保持一定的距离。

**2.8.3** 塔机触及电源后，应按下述处置：

- 留在塔机内；
- 将塔机开出危险区；
- 警告未涉及人员不要靠近或触及塔机；
- 断开电源；
- 在碰到的 / 损坏的电源线未完全断开之前，不要离开塔机。

**2.8.4** 处理塔机非正常的电气系统或设备，应由有资质的电气工作人员或专业人员按电气工程规则与规程进行作业。

**2.8.5** 除电气工程的特定规程外，塔机的机构及电气系统的电源，在进行维护时必须断开。

**2.8.6** 工作之前，除隔离相邻带电源部件或元件之外，应检查断电部件是否有电或短路，接地是否良好。

**2.8.7** 塔机的电气设备要定期检查，对于接头松动或电缆损坏等缺陷，必须马上修复。

**2.8.8** 对带电的部件和元器件进行处理时，应使用绝缘良好的工具，同时必须有二人在场时方可进行，其目的是密切注视。一旦发生危险，随时关闭或切断电源。工作区域应用红白条标志设置警戒区域。

**2.8.9** 在高压组件开始工作之前和切断电源之后，供电电缆必须接地。电容器等电气部件应随接地杆短路。

## **2.8 Special hazard warnings (power)**

**2.8.1** Use only the original fuse with specified current rating.

**2.8.2** When operating near high-altitude wire, the tower crane should maintain a certain distance from aerial wires.

**2.8.3** Tower after hitting power, the following shall dispose of:

- Stay in the tower;
- Operate tower crane out of the danger zone;
- Warning not involved people not to close or touching tower;
- Disconnect the power supply;
- Before the encountered or damaged power cord is not completely disconnected, do not leave the tower.

**2.8.4** Dealing with tower crane abnormal electrical systems or equipment shall have a qualified electrician or professional staff to conduct operations as the electrical engineering rules and regulations.

**2.8.5** In addition to the specific rules of electrical engineering, the power of tower crane bodies and electrical systems must be disconnected during maintenance.

**2.8.6** Before work, in addition to the isolation of adjacent components or components with power, you should check whether electrical power components are shorted or grounding connection is good.

**2.8.7** Tower crane electrical equipment should be regularly checked. Loose connections or cable damage and other defects must be repaired immediately.

**2.8.8** When processing the charged parts and components, you should use well-insulated tools and carry out when there are two people present, in order to closely monitor. Once the danger instantly cut off or disconnected from the power supply. At working area you should set warning area by application of red and white flag.

**2.8.9** The high-pressure components, before beginning work and cut off the power supply cable must be grounded. Capacitors and other electrical components should be short-circuited with the ground rod.

## **2.9 液压和气动设备**

**2.9.1** 对液压和气动设备的作业应由有资质的液压和气动专业人员进行。

**2.9.2** 定期检查油路、软管和螺纹接头是否泄露或有无明显损坏。如有损坏立即修复。处置时，要注意飞溅的油引起的烫伤、环境污染和着火。

**2.9.3** 所有系统装置和压力管路（液压系统，压缩空气系统），在进行维修保养时，应按相关装置的具体说明进行卸压作业，确保安全拆卸。

**2.9.4** 液压和压缩空气管路必须正确铺设和固定。软管接头、长度和质量必须符合技术要求。

## **2.9 Hydraulic and Pneumatic Equipment**

**2.9.1** The job for hydraulic and pneumatic equipment shall be done by qualified hydraulic and pneumatic professionals.

**2.9.2** Regularly check the oil, hoses and threaded fittings for leaks or any obvious damage. Immediately repair any damage. In disposal, pay attention to oil splash burns caused by environmental pollution and fire.

**2.9.3** All system devices and pressure piping (hydraulic systems, compressed air systems), during maintenance, you should conduct the relevant specified relief operations to ensure the safety of the demolition.

**2.9.4** Hydraulic and compressed air piping must be properly laid and fixed. Hose connector, length and quality must meet the technical requirements.

**2.10 噪音：**操作期间，塔机上所有隔音板必须关闭。

## **2.11 油、油脂和其它化学物质**

当处理油、油脂和其它化学物质时，应遵守与产品安全和环境保护有关的规程。要注意处置热燃材料（有烧伤或烫伤危险）。

**2.10 Noise: During the operation, all soundproof panels on the tower must be closed.**

## **2.11 Oil, grease and other chemicals**

When dealing with oil, grease and other chemical substances, you shall comply with the relevant product safety and environmental protection regulations. Pay attention to the disposal of hot burning material (there are burns or scalding hazard).

## **2.12 计量单位**

### **注意**

新型有效装置按“公制”

所有数据用公制换算和取舍数值。

### **代码和标志技术规范（结构分析）**

X=作用力方向平行于起重臂

Y=作用力方向正交于起重臂

质量 Kg/t (公斤/吨)	G=自重
	P=载荷
	A=启动力
	M=载荷力矩
	W=风力
力 N(牛顿)	D=压力
	Z=拉力
原单位制 KP ; MP ; dyn ;	
1KP 10N*=1daN	
1MP 10000N*=10KN	
1dyn=10 <sup>-5</sup>	
扭矩 N. m (牛顿米)	
	M=塔机的 G、P、M 和 W 扭力
原单位制 KP. m	M <sub>x</sub> 塔机的 G、P、M 和 W 扭
1Nm 0.010KPm9	M <sub>T</sub> = P、G 和 W 扭力
1KPm 10Nm=1 daNm	N=G 和 P 的垂直力
	S=所处方位角的垂直力
能量, 功率 kW. h(千瓦. 时)	Q= P、G 和 W 的水平力
	H <sub>0</sub> =顶水平力
以前单位 PSh (BHP)	H <sub>U</sub> =底水平力
1 kpm 10Nm*=1 daNm	H <sub>M</sub> =所处方位角 M 水平力
1 kWh=1.36 PSh* (HPh)	H <sub>Q</sub> =所处方位角 Q 水平力
	H <sub>MT</sub> =所处方位角 M <sub>T</sub> 水平力
功率用 Kw(千瓦)	H=全部水平力之和
功率用 Kw(千瓦)	H=全部水平力之和
	E=最大支撑力
原单位制 BHP	
1 kW=1.36 BHP	
1 BHP=0.736Kw*	
压力用 bar(巴)	

原单位制  $\text{kp} / \text{cm}^2$

$1 \text{ bar} \sim 1 \text{ kp} / \text{cm}^2$

速度用  $1 / \text{min}$  (转数每分钟)

以前单位 rpm

$1 / \text{min} = 1 \text{ rpm}$

$1 \text{ rpm} = 1 / \text{min}$

组合单位符号里没有空格例如: daNm。

组合单位符号里没有空格例如: Nm

\*换算系数按 DIN 1 333 四舍五入。

## 2.12 Units of measurement

**Note: that the code and flag technical specifications (structural analysis)**

New and effective means by "metric"

Metric Conversion of all data values and trade-offs. X = the force in a direction parallel to the boom

Y = the force in the direction orthogonal to the jib

G = weight

P = load

Quality Kg / t (kg / t)

A = start force

M = load moment

W = wind

Force N (Newton)

D = Pressure

Z = Tension

Original units KP; MP; dyn;

$1 \text{ KP} = 10 \text{ N} = 1 \text{ daN}$

$1 \text{ MP} = 10000 \text{ N} = 10 \text{ KN}$

$1 \text{ dyn} = 10^{-5} \text{ N}$

Torque N.m (Newton meters)

	M = tower crane G, P, M and W Torque
Original units KP.m	MX tower crane G, P, M and W Torque
1Nm 0.010KPm <sup>9</sup>	MT = P, G and W torque
1KPm 10Nm = 1 daNm	N = vertical force G and P
	S = the azimuth angle in which the vertical force
Energy, power kW • h (KW • H)	Q = P, G and W horizontal force
	H <sub>0</sub> = top horizontal force
Previous units PSh (BHP <sub>h</sub> )	H <sub>U</sub> = bottom horizontal force
1 kpm 10Nm * = 1 daNm	H <sub>M</sub> = horizontal force at azimuth M
1 kWh = 1.36 PSh * (HP <sub>h</sub> )	H <sub>Q</sub> = horizontal force at azimuth Q
	H <sub>MT</sub> = horizontal force which azimuth MT
Power with Kw	H = the sum of all the horizontal force
Power with Kw	H = the sum of all the horizontal force
	E = maximum support force
BHP original units	
1 kW = 1.36 BHP	
1 BHP = 0.736Kw *	
Pressure with bar (bar)	
Original unit system: kp / cm <sup>2</sup>	
1 bar ~ 1 kp / cm <sup>2</sup>	
Speed is 1 / min (rotating number every minute)	

Previous unit: rpm

1 / min = 1 rpm

1 rpm = 1 / min

There is no space in symbol combination units such as: daNm.

There is no space in symbol combination units such as: Nm

\* Conversion factor according to DIN 1 333 rounding.

技术数据

第三章

3.1	总则	3-3
3.1.1	塔机部件	3-3
3.1.2	起重臂长度、臂端最大吊载图	3-3
3.1.3	塔机配置，吊钩高度	3-5
3.1.4	不同组合起重臂的平衡重配置	3-7
3.1.5	平衡重制作配筋圈	3-7
3.1.6	钢丝绳规格、结构	3-9
3.1.7	部件单件重量表	3-10
3.2	塔机的基础设置	3-13
3.2.1	塔机的基础载荷	3-14
3.2.2	混凝土基础准备	3-15
3.2.3	混凝土基础配筋图	3-15
3.2.4	接地	3-15
3.2.5	电源	3-17

**Technical data**

**Chapter 3**

3.1	Overview	3-3
3.1.1	Tower crane parts	3-3
3.1.2	Jib length with 2/4 fall load	3-3
3.1.3	Tower crane configuration and hook height	3-5
3.1.4	Counterweight configuration for different jib length	3-9
3.1.5	Counterweight steel-bar	3-9
3.1.6	Rope specification	3-12
3.1.7	Part transportation and Installation	3-13
3.2	Foundation configuration	3-18
3.2.1	Foundation load	3-18
3.2.2	Concrete foundation preparation	3-18
3.2.3	Concrete foundation steel-bar	3-18
3.2.4	Grounding	3-20
3.2.5	Power supply	3-21

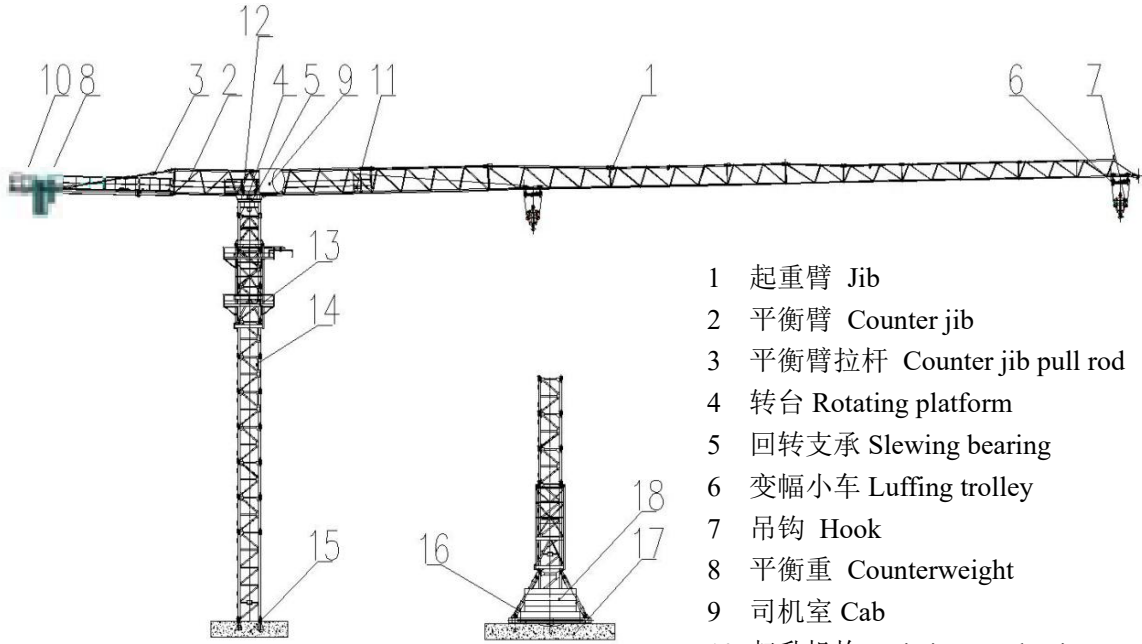


### 3.1 总则

#### 3.1.1 塔机部分

#### 3.1 Overview

#### 3.1.1 Tower crane part (Fig 3-1)



- 1 起重臂 Jib
- 2 平衡臂 Counter jib
- 3 平衡臂拉杆 Counter jib pull rod
- 4 转台 Rotating platform
- 5 回转支承 Slewing bearing
- 6 变幅小车 Luffing trolley
- 7 吊钩 Hook
- 8 平衡重 Counterweight
- 9 司机室 Cab
- 10 起升机构 Hoisting mechanism
- 11 变幅机构 Luffing mechanism
- 12 回转机构 Slewing mechanism
- 13 爬升架 Climbing frame
- 14 塔身节 Tower mast
- 15 固定基础 Fixed base
- 16 底架 Chassis
- 17 底架基础 Chassis base
- 18 压重 Counterweight

图 1 Fig 1

3.1.2 起重臂长度 臂端最大吊载图

3.1.2 Jib length and maximum load at jib end

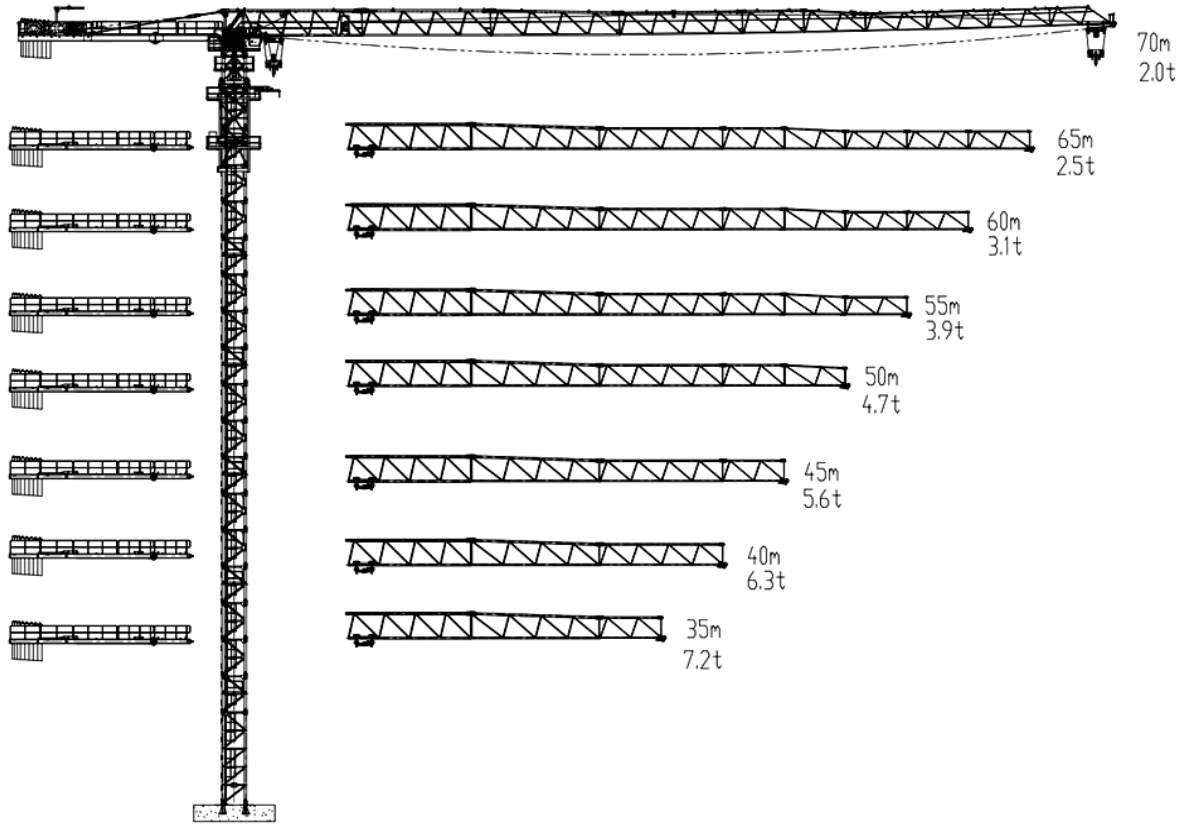


图 2 Fig 2

备注：上图为 2 倍率臂端吊重，4 倍率吊重详见吊载性能表

Not:the above 2 ratio hoisting arm end,4 ratio hoisting crane load performance the barrier.

3.1.2.1 载荷性能表

3.1.2.1 Load characteristics

幅度	倍率	Max(m/Kg)	3	15	20	30	35	40	45	50	55	60	65	70
70m	a=2	3-28.6 m 6000Kg	6000			5766	4825	4119	3569	3130	2770	2471	2217	2000
	a=4	3-15.1 m 12000Kg	12000	8836	5562	4626	3924	3379	2942	2585	2287	2035	1800	
65m	a=2	3-31.6 m 6000Kg	6000			5334	4567	3970	3492	3101	2776	2500		
	a=4	3-16.5 m 12000Kg	12000	9760	6177	5154	4386	3769	3311	2920	2595	2300		
60m	a=2	3-34.4 m 6000Kg	6000			5801	5053	4402	3881	3455	3100			
	a=4	3-18.0 m 12000Kg	12000	10733	6826	5710	4873	4221	3701	3274	2900			
55m	a=2	3-38.0 m 6000Kg	6000				5665	4946	4371	3900				
	a=4	3-19.9 m 12000Kg	12000	11956	7642	6409	5484	4765	4190	3700				
50m	a=2	3-40.4 m 6000Kg	6000					5312	4700					
	a=4	3-21.2 m 12000Kg	12000		8190	6879	5896	5131	4500					
45m	a=2	3-42.3 m 6000Kg	6000					5400						
	a=4	3-22.2 m 12000Kg	12000		8623	7250	6220	5600						
40m	a=2	3-40.0 m 6000Kg	6000											
	a=4	3-22.5 m 12000Kg	12000		8729	7340	6300							
35m	a=2	3-35.0 m 6000Kg	6000											
	a=4	3-22.2 m 12000Kg	12000		8564	7200								
30m	a=2	3-30.0 m 6000Kg	6000											
	a=4	3-22.0 m 12000Kg	12000		8500									



上述载荷性能表是根据 XGT7020-12 塔机独立高度(60m)计算而得出的,当起升高度大于 60m 时,起升性能中的起重量必须降低。计算方法为:计算高度的起重量=性能表中的起重量-每米钢丝绳的重量×(计算高度-60)×倍率。(单位:高度:m;重量:Kg)起升钢丝绳为 16 35Wx7 1770 U ZS, 钢丝绳重量为 119kg/100m。



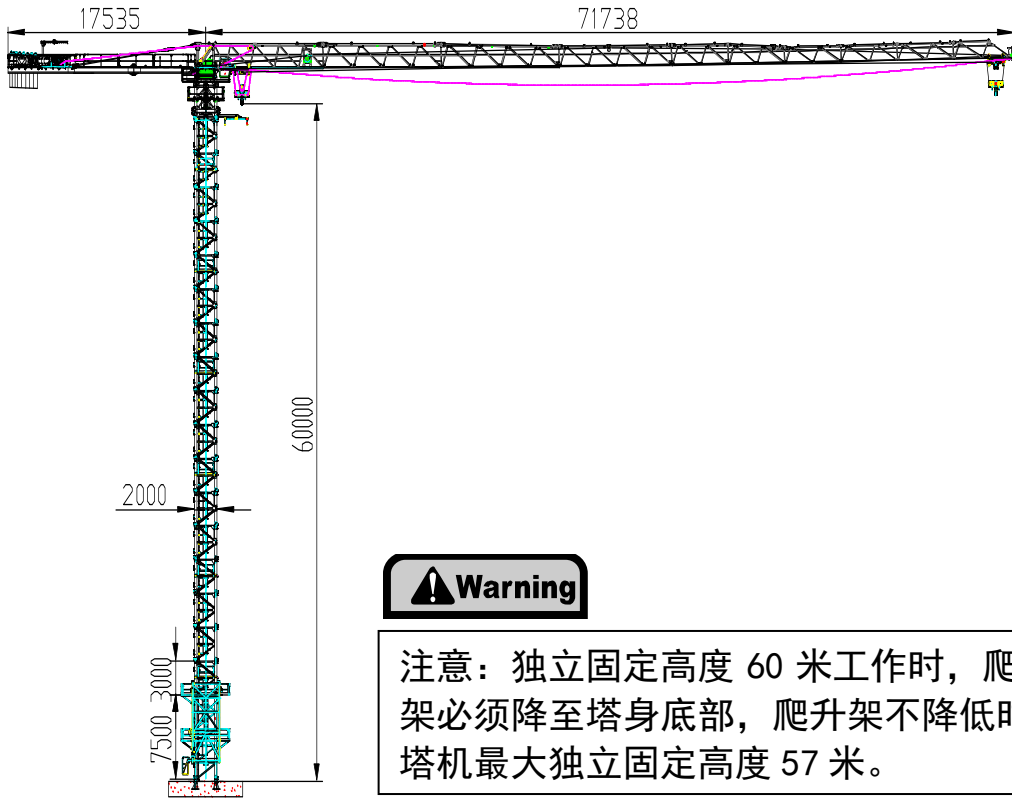
The above load parameters are calculated based on the independent fixed height (60m) of XGT7020-12. When the lifting height is greater than 60m, the lifting load must be reduced. Calculated as follows: lifting height of calculated height = the load in the table - the weight of per meter wire rope × (calculated height - 60) × fall. Hoisting rope is 16 35Wx7 1770 U ZS, and the rope weighs 94kg/100m.

### 2.1.3 塔机配置, 吊钩高度

独立固定式塔机由 1 节基础节、17 节标准节和 1 节特殊节组成, 独立固定式最大起升高度为 60m。固定附着式塔机由 1 节基础节、77 节标准节和 1 节特殊节组成, 最大起升高度为 201m。

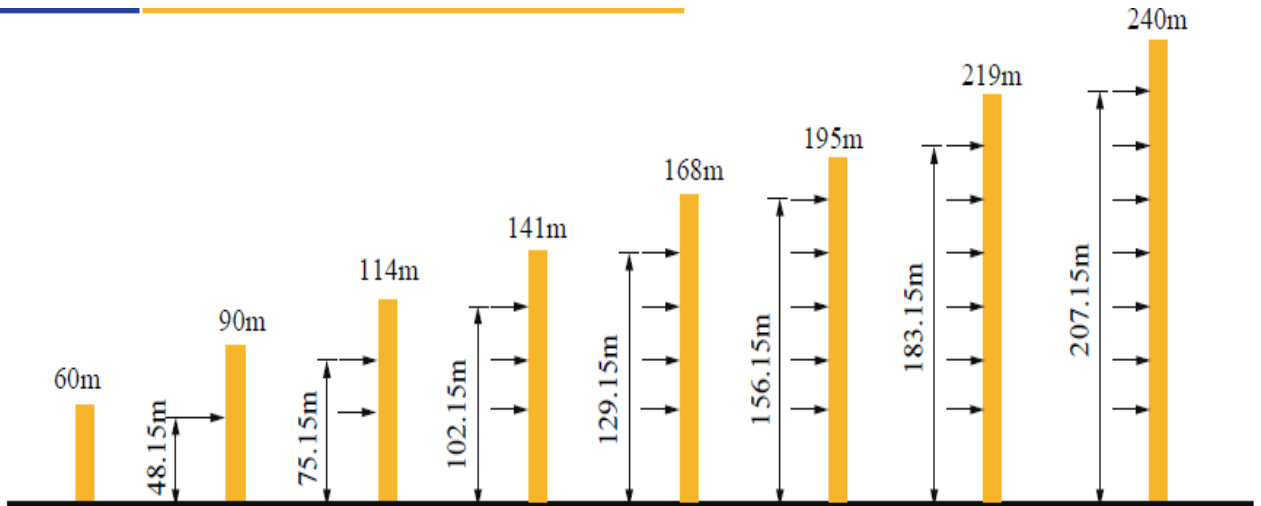
### 2.1.3 Tower Crane configuration and hook height

The independent-stationary tower crane consists of one base section, seventeen masts and one special mast. Its independent height is 60m. The attached tower crane consists of one base section, 71 masts and one special mast, with the maximum lifting height of 222m.



独立固定式

Independent-Stationary towercrane



**3.1.4 不同组合起重臂的平衡重配置**

平衡重有三种 A=3.1t、B=2.0t、C=1.5t，不同臂长每种平衡重数量见下表：

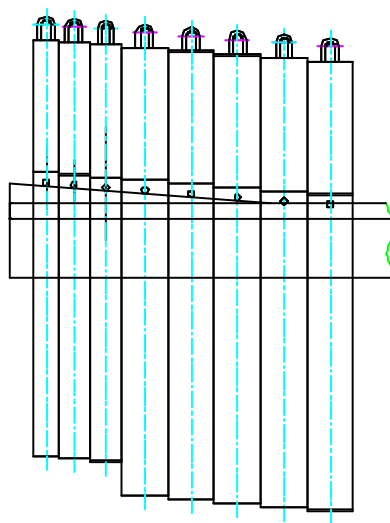
**3.1.4 Counterweight configuration for different jib combinations**

There are three kinds of counterweight: A=3.1t and B=2.0t and C=1.5t. The counterweight number for different jib length is shown in the following table:

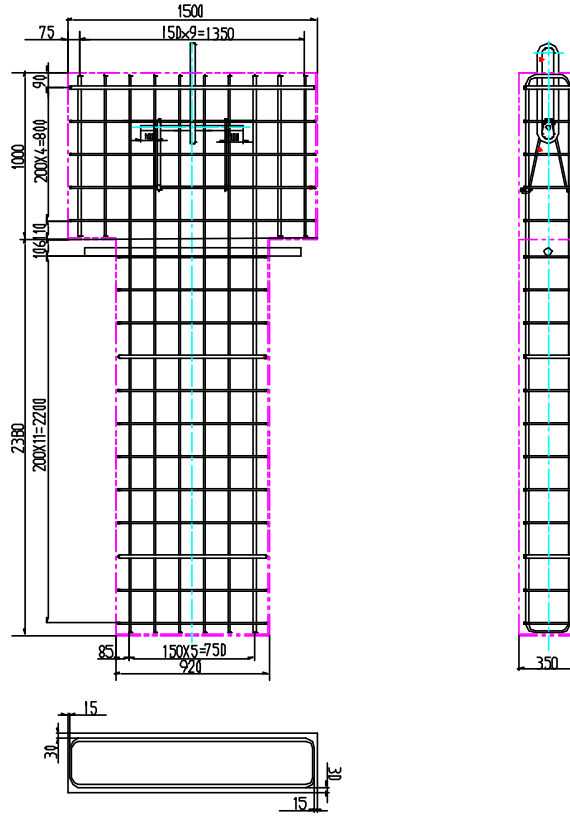
	A	B	C
70m	5	2	1
65m	5	2	1
60m	5	2	0
55m	5	1	1
50m	4	2	1
45m	4	2	0
40m	4	1	0
35m	4	0	0
30m	3	0	1

**3.1.5 平衡重制作配筋图（见随机文件）**

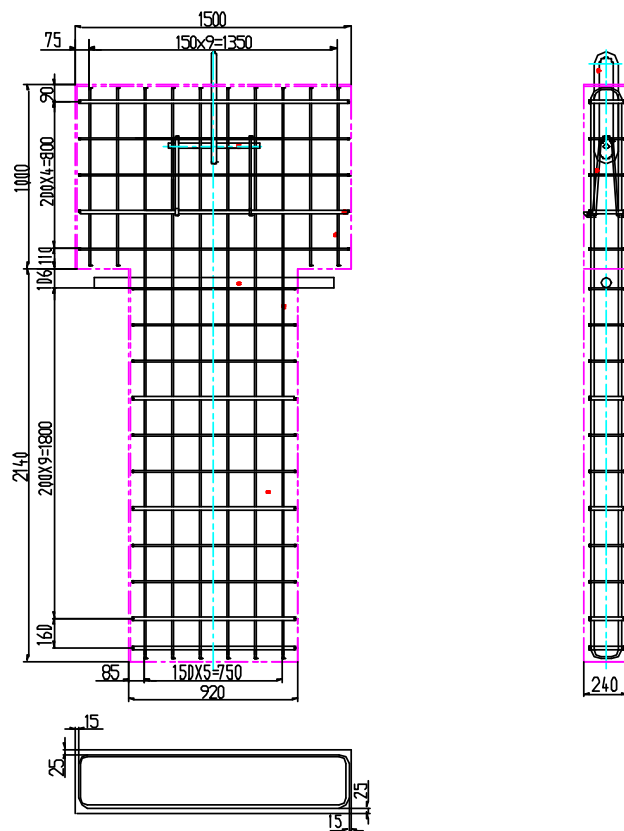
**3.1.5 Fabrication of counterweight (Attached Files)**



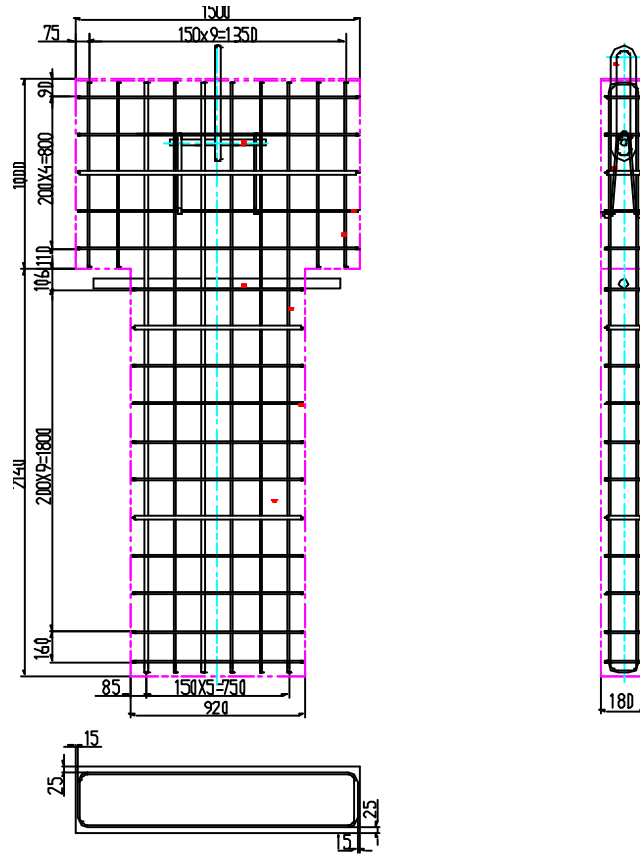
平衡重配置图 Configuration of counterweight



平衡重 A: Counterweight A=3100Kg



平衡重 B: Counterweight B=2000Kg



平衡重 C: Counterweight C=1500Kg

3.1.6 钢丝绳规格、结构

3.1.6 Rope specification and structure

使用部位 Use position	标准号及规格 Standard and specification		绳径 Rope diameter	数量 Qty	每根长度 Length of per rope		
起升机构 Lifting mechanism	GB/T8918-2006 16 35Wx7 1770 U ZS		16	1	360m		
小车牵引机构 Trolley traction mechanism	绳 Rope II	GB/T8918-2006 7.7 6×19+FC 1670 U ZS	7.7	1	臂长 Jib length	40m	85m
				1		45m	95m
				1		50m	105m
				1		55m	115m
				1		60m	125m
				1		65m	135m
				1		70m	145m
	绳 Rope I	GB/T8918-2006 7.7 6×19+FC 1670 U ZS	7.7	1	臂长 Jib length	40m	60m
				1		45m	65m
				1		50m	70m
				1		55m	75m
				1		60m	80m
				1		65m	85m
				1		70m	90m

注：1、此表载重小车牵引机构一栏中，钢丝绳的长度变化是与选用何种起重臂臂长相对应的

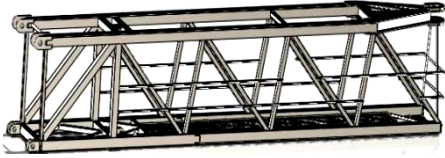
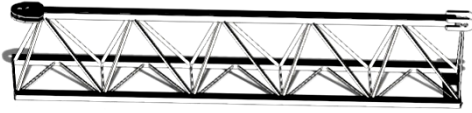
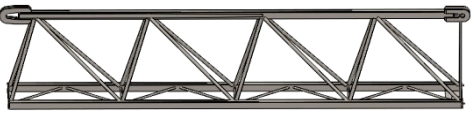



2、此表起升钢丝绳长度是按 4 倍率起升高度 60m 提供，用户应根据实际使用高度决定所需长度。

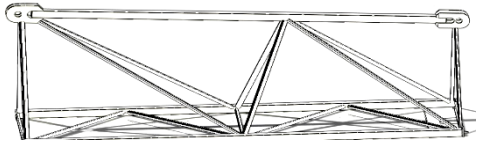
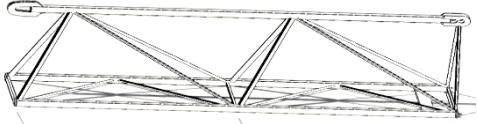
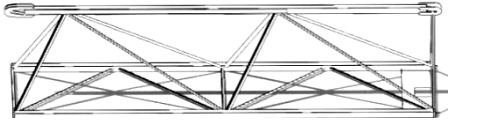
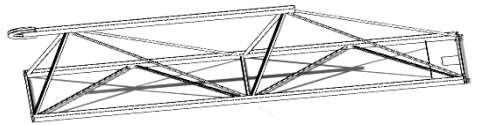
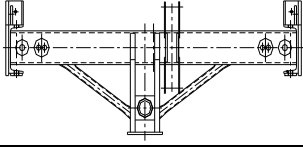
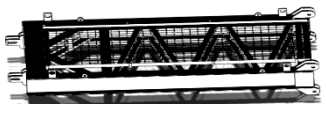

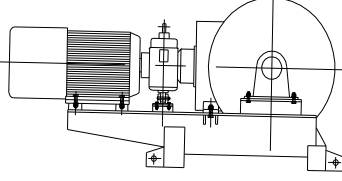
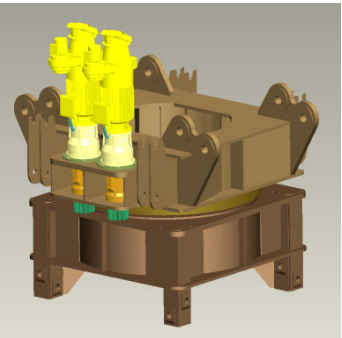
Note: 1. in Trolley traction mechanism column, the changes of rope length are subjected to the changes of jib length.


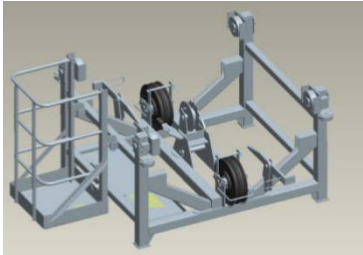
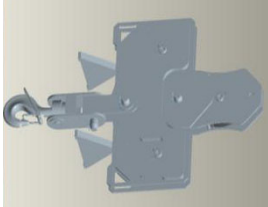
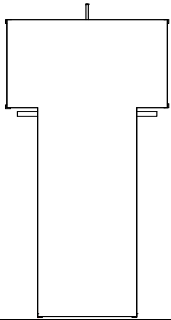
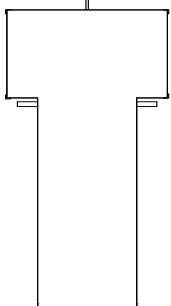
2. The hoisting rope length is provided for 4-fall with lifting height of 60m. Users can decide the actual height according to actual needs.

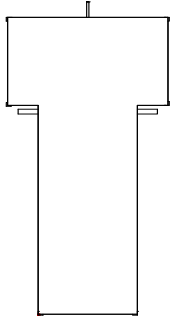
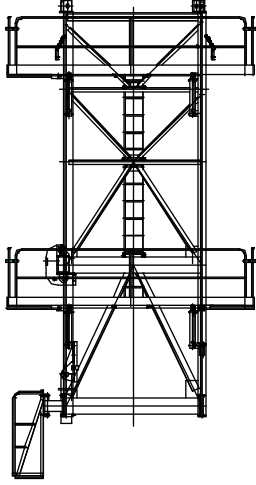
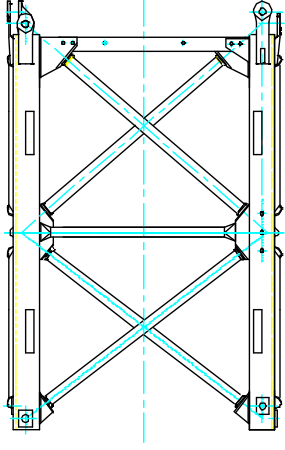
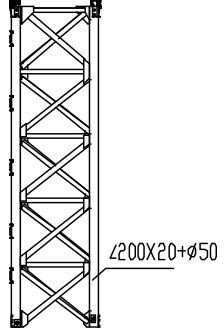
3.1.7 部件单件重量表

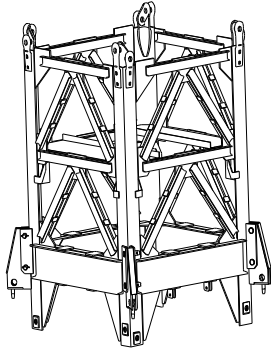
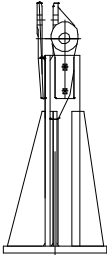
3.1.7 Component weight table

部件 Part	件数 Qty	名称 Name	简图 Figure	长(m) Length	宽(m) Width	高(m) Height	单件 重量 Weight (Kg)
上部结构 Upper structure	1	起重臂 M1+变幅 机构 Jib M1 and luffing mechanism		11.52	1.41	2.26	5495
	1	起重臂 Jib M2		10.6	1.41	2.24	2497
	1	起重臂 Jib M3		10.6	1.41	2.24	1875
	1	起重臂 Jib M4		10.29	1.41	1.90	1473
	1	起重臂 Jib M5		5.27	1.41	1.84	699
	1	起重臂 Jib M6		5.25	1.41	1.82	552

1	起重臂 Jib M7		5.22	1.41	1.57	419
1	起重臂 Jib M8		5.19	1.41	1.56	359
1	起重臂 Jib M9		5.14	1.45	1.54	336
1	起重臂 Jib M10		5.12	1.45	1.54	290
1	起重臂端部 Jib end		0.61	2.57	1.27	128
1	第1节平衡臂 Counter jib 1		5425	1.55	0.78	1825
1	第2节平衡臂 Counter jib 2		11.38	1.55	0.78	1018
1	起升机构+钢丝绳 Lifting mechanism and steel rope		2.90	2.16	1.31	1500
1	回转总承+回转机构 Slewing unit and slewing mechanism		2.46	2.30	2.480	5342

1	驾驶室 Cab		3.70	2.15	2.25	450
1	变幅小车 Trolley		2.3	1.90	1.35	388
1	吊钩 Hook		1.3	0.50	2.1	458
6	配重 1 Counterweight 1		3.38	0.35	1.5	3100
1	配重 2 Counterweight 2		3.14	0.24	1.5	2000

	1	配重 3 Counterweight 3		3.14	0.18	1.5	1500
	1	爬升架 Climbing frame		2.48	2.48	7.26	5835
	17	标准节 Mast		2	2	3	1764
	1	基础节 base section		2	2	7.5	4182

1	过渡节 transition section		2.5	2.3	3.3	3380
4	固定支脚 Fixed outrigger		0.6	0.6	1.195	288

注：重量/件

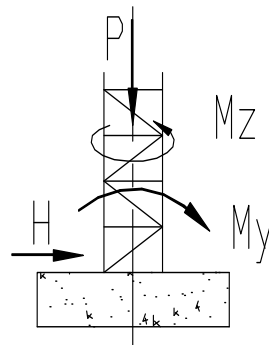
Note: weight/per piece

### 3.2 塔机的基础设置

#### 3.2.1 塔机的基础载荷(表 3-1)

#### 3.2 Basic configuration of tower crane

#### 3.2.1 Base load of tower crane (Table 3-1)



P, H—kN      My, Mz—kN.m

工况 Condition 载荷 Load		工作工况 Working condition	非工作工况 Non-working condition
基础 载荷 Base load	P	1111.79	1006.97
	H	54.3	173.5
	My	5143.6	5639.9
	Mz	512	0

H(m)		YM1	YM2	YM3
51	F <sub>g</sub> (t)	206	249	294.8
	P <sub>B</sub> (MPa)	0.2	0.16	0.13
	B (m)	7.1	7.8	8.5
	H (m)	1.7	1.7	1.7

表 3-1 Table 3-1

### 3.2.2 混凝土基础准备

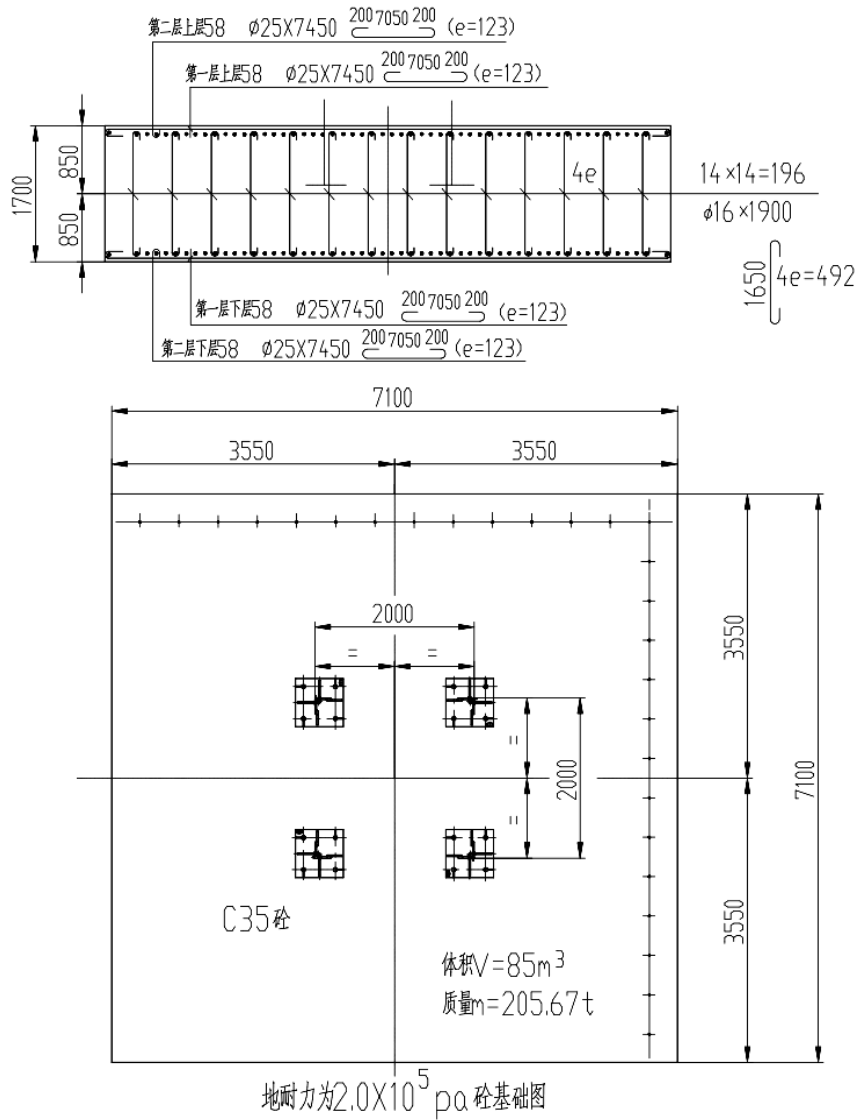
基础坑开挖后，将钢筋网组装，并将固定板和锚固螺栓按下图尺寸置于基础坑中间。用塔机的标准节进行水平与垂直调整。混凝土基础的混凝土应采用高强度混凝土浇注。

### 3.2.3 混凝土基础配筋图（详见随机图纸）

#### 3.2.2 Concrete foundation preparation

Dig the foundation pit and assemble steel-bar mesh. Set the fixing plate and anchor bolt in foundation pit as the size in the following figure. Adjust in horizontal and vertical by using tower mast. The concrete foundation shall be poured by high strength concrete.

#### 3.2.3 Steel-bar of concrete foundation (Details in Attached Files)



基础图 Base Figure

### 3.2.4 接地装置

本节“接地”一词指塔机与接地网的联接，不是指塔机与 PE 线（电网保护地线）的联接。

不同气象和地理条件的地区，接地网的制作方法差距很大，应依据塔机实际使用地区的用电监察部门提供的制作规范进行。各地方供电局都为变压器中点接地网、烟囱避雷针接地网等提供标准做法，可参照。北京地区可参照北京市供电局编发的《电气施工安装图册》。完成后的接地网，其接地电阻值应小于  $4\Omega$ 。不能满足时，可扩大接地网或并接第二接地网，仍不能满足时，向本地用电监察部门咨询。如该地区允许使用化学降阻剂，本塔机也可以用。

固定式塔机可由地脚上专用的接地螺栓与接地网相联，应不少于两根引线。

本地方的有关规程允许使用自然接地体时，塔机可以将其作为重复接地网使用，其值应在  $4\Omega$  以下。

在感应电磁波强烈的地区，接地不能完全消除大钩带电现象。依国家有关规定，起重工此时应穿绝缘靴、戴绝缘手套工作。

塔机新立、转场，接地电阻均应使用专用接地摇表测量并记录。雷雨季节到来之前应再次摇测。

#### 3.2.4 Grounding device

In this section the term "grounding" refers to the connection of the grounding grid with tower crane, not the PE line connection (grid protective earth).

For different weather and geographical conditions of the region, the gap between production methods grounding grid is large, so the grounding device fabrication should be based on actual use of the tower crane production specification region according to the standard provided by related electricity monitor sector. Local power supply bureau announces the standard practice of transformer midpoint grounding grid and grounding grid of chimney lightning rod. Beijing area can refer to Beijing Power Supply Bureau and the "Electrical construction and installation of Atlas." Upon completion of the grounding grid, the grounding resistance should be less than  $4\Omega$ . Otherwise, you can expand the grounding grid and then the second ground grid. If the resistance still not meets the requirement, consult to local electricity monitoring department. If the area is allowed to use chemical reducing agent, this tower crane can also be used.

Stationary tower crane can be connected with grounding grid by special grounding bolt, which should have at least two leads.

When the relevant regulations allow the use of the local natural grounding, it can be

used as a ground network to be repeatedly used, while its value should be less than  $4\Omega$ .

In a strong electromagnetic induction area, the ground cannot completely eliminate the hook electrification. In accordance with relevant state regulations, you should wear insulated boots and work with insulated gloves.

After tower crane new legislation and transitions, grounding resistance should be measured and recorded using a dedicated megger. Do the test again before the arrival of the thunderstorm season.

塔机接地的三种形式供用户参考：

图 A 接地棒形式：序 1 钢管  $\phi 33 \times 4.5$ ，长 1.5~2m，序 2 接地道钉，序 3 为监护接地道钉留观察孔且道钉不需防水。

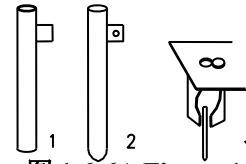


图 1.6-6A Figure 1.6-6A

图 B 接地板形式：用钢板制作，面积为 1 米<sup>2</sup>，立埋。

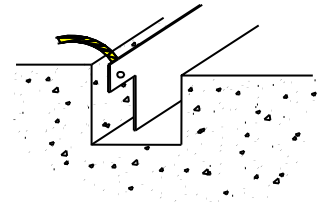


图 1.6-6B Figure 1.6-6B

图 C 埋地线形式：截面为 28 毫米<sup>2</sup>的铜导体或截面为 50 毫米<sup>2</sup>的铁导体在线槽内，延伸长度要取决于地阻。

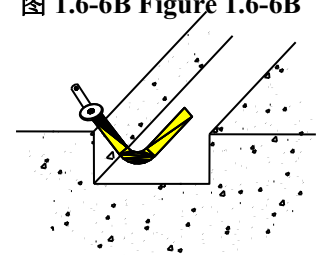


图 1.6-6C 接地装置  
Fig 1.6-6C Grounding device

There are three forms of tower crane grounding for reference:

Figure A grounding rod forms: No.1 pipe  $\phi 33 \times 4.5$ , 1.5 ~ 2m long, No.2 is ground spike, and No. 3 is observing hole for ground spike. The spike does not need waterproof.

Figure B ground plate form: made of steel. Area:  $1\text{m}^2$ , vertically buried.

Figure C ground wire burying form: copper conductor of  $28\text{mm}^2$  cross-section, or the Fe conductor of cross-section of  $50\text{mm}^2$  in lineslot,

Extending the length depends on the resistance.



接地导线必须连接在其中任何一根固定支腿（主弦杆）上！

### 3.2.5 电源

塔机的电气设备必须始终近接在屏蔽接地线路上。提供塔机所用的电源和连线 / 接头以满足其电能需要，并使之符合标准电气规范和塔机使用地区的电气安装规程，同时应符合本章节描述的技术规范。

**3.2.5.1** 接地导线其导体的最长长度和截面直径，应符合使用电源的负载。

**3.2.5.2** 对外露电缆和穿过地下导管的电缆，建议使用耐火电缆。对于其它形式的安装，

**警告** 使用电缆卷筒，建议选择截面、长度、重量和弯曲半径适合类型的电缆。

**3.2.5.3** 电源必须满足特殊塔机的要求并符合标准规定的要求

**3.2.5.4** 电压波动要求必须控制在 10%公差之内。

**3.2.5.5** 用户应保证电源电压和频率要求，能满足操作塔机符合的技术规范和标准。

**注意** 塔机的电源如采用发电机组，频率要求非常重要。

**3.2.5.6** 制造商的技术部门应按照用户的建议，进行必需的技术支持，为施工现场的特殊要求提供及时良好的服务。

**3.2.5.7** 根据塔机的电气要求必须提供电源的超载保护装置。

**3.2.5.8** 塔机和保护屏蔽接地线路之间的连接必须在连接到主电源之前完成。

**Warning** Grounding wire shall be connected on one of the fixed angles (main chord)!

### 3.2.5 Power supply

The electric equipment of tower crane is always connected on the protective grounding circuit. You should provide the power supply and power wire and joint to meet the energy requirements as well as the requirements of electricity regulations and electric installation procedures and the technical specification in this chapter.

**3.2.5.1** Grounding wire and max length and section diameter of its conductor shall meet the requirement of used power supply load.

**Warning**

**3.2.5.2** For outer cable and through-ground cable it is recommended to adopt fire-proof cable. And for other installations, for example, the cable drum, you should choose proper cable in section, length and weight, as well as bending diameter.

**3.2.5.3** The power supply should also meet the special requirement for tower crane.

**3.2.5.4** Fluctuating of voltage needs to be controlled within 10% tolerance.



**3.2.5.5** Users need to make sure the power supply voltage and frequency meets the technical requirements and standard for tower crane.

Note: the frequency is very important for tower crane if it adopts with generator set.

**3.2.5.6** Manufacturers should give users some recommendation and provide certain technical service.

**3.2.5.7** You should provide the overload protection device for power supply device according to the electric demands of tower crane.

**3.2.5.8** Complete the connection between tower crane and protection grounding wire before connecting main power supply.

安装总体说明

第四章

4.	施工现场的准备	4-3
4.1	准备	4-3
4.2	地面承载力	4-3
4.3	塔机安装区	4-3
4.4	多台塔机的运行	4-3
4.5	施工现场的条件	4-4
4.6	塔机安装队伍与作业人员的条件	4-4
4.7	安全警示标识	4-5
4.8	永久性标识说明	4-9

Installation Instruction

Chapter 4

4.	Site preparation	4-3
4.1	Preparation	4-3
4.2	Ground endurance	4-3
4.3	Tower crane installation site	4-3
4.4	Operation of multi-crane	4-3
4.5	Situation of construction site	4-4
4.6	Installation team and personnel requirement	4-4
4.7	Safety warning	4-5
4.8	Permanet identification	4-9

## **4. 施工现场的准备**

### **4.1 准备**

塔机用户应负责塔机施工场地的准备，塔机运行就位地面的清理、找平、铺设、加固及制造商提出的针对安装可行性的验证应由用户进行。

### **4.2 地面承载力**

塔机进场之前，施工场地的土层应满足各种规格及不同高度的塔机对基础承载力的需求，或行走式塔机对导轨铺设的平整要求。用户应按施工场地的地质勘探报告，对塔机就位场地进行认真地探讨决策。

#### **塔机安装区**

在选择塔机施工现场时，用户应注意确保塔机在作业范围不得受阻，即：当塔机在非工作状态时，塔机自由回转的起重臂不得与周边建筑物、塔机、树木与输电电缆以及施工建筑物、施工场地脚手架、建筑材料与其它机械设备等碰撞。

## **4. Construction site preparation**

### **4.1 Preparation**

Users should be responsible for tower crane construction site preparation, cleaning of tower machines running floor, leveling, laying of reinforcement. Manufacturers raise the feasibility for installation needed to verify by the user.

### **4.2 Ground bearing capacity**

Before entering the tower crane, construction site soil should meet a variety of requirements of tower crane with various specifications and heights for foundation bearing capacity, or travelling tower crane requirements for rails. Users should do the geological exploration and take serious decision.

### **4.3 Tower crane installation area**

When selecting tower construction site, users should ensure no restriction on operating the tower crane, i.e.: when the tower crane is at the non-working state, its slewing jib shall be without collisions with the surrounding buildings, tower cranes,

trees and transmission lines and construction of buildings, construction site scaffolding, building materials and other machinery and equipment.



周围的输电电缆必须在塔机网转半径最小安全距离 5 米以上。



注意：在塔机安装前，应与当地电业部门联系，以确定塔机与高压电缆或输电变压器的最小安全距离！

#### 4.4 多台塔机的运行

当同一施工现场有两台以上塔机在近距离作业时，应采取以下防护措施：



- 1.应预测起重臂有避免碰撞的最大幅度和安全距离。
- 2.为防止不同高度的上下两台塔机的起升钢丝绳和载荷的相互干扰，塔机应保持足够的距离。
- 3.在限制塔机的作业范围，准备安装塔机的防碰撞装置时，应咨询制造商有这类防碰撞装置的安全问题，经确认后，方可进行。



Transmission cable around the tower machine must be at 5 m above the rotating minimum radius of safety distance.



Before installing the tower crane, you should contact your local electric utility to determine the minimum safe distance from the tower crane and high-voltage cables or transformer!

#### 4.4 Operation of multi-cranes

When there are two or more of tower cranes operating at the same construction site at close range, you should take the following precautions:



1. You should predict the max radius and safe distance to avoid collisions.

2. **To prevent mutual hoisting wire rope and load interference of the two cranes with different heights and, the tower should keep enough distance.**
3. **In limiting scope of tower crane operations, you should consult the manufacturer about anti-collision safety device when you are ready to install it.**

#### 4.5 施工现场的条件

塔机安装工作前，塔机的有关监督部门 / 人员应对施工现场进行检查，确保所有安装的机构、部件安置妥当，以便于安装的顺利进行。

4.5.1 塔机的安装应在施工现场符合以下要点，并经有关监督部门/人员检查确认：

- a) 塔机的作业运行区是否有障碍物(如：建筑物、树、电缆等)；
- b) 混凝土制作的基础、平衡重、压重是否达到技术要求；
- c) 混凝土制作的基础、平衡重、压重是否符合强度要求；
- d) 安装塔机的起重设备是否符合塔机的安装要求；
- e) 安装塔机的起重设备各种安全限位装置是否灵敏可靠；
- f) 塔机的电气连接是否可靠有效；
- g) 应着重检查安装塔机的起重设备的吊具(如：起重吊钩、起重吊链、钢丝绳等)。

#### 注意

1.有关监督部门 / 人员应对安装塔机的起重设备作业人员进行安装塔机各机构、部件的起吊重量的交底。

2.安装塔机的起重设备作业人员应对所交底的各机构、部件的起吊安全负责。

具体的机构、部件的起吊重量见本使用说明书第 5 章塔机安装。

#### 4.5 Construction site conditions

Before tower crane installation, relevant supervision departments or personnel should inspect the construction site to ensure that all installation mechanisms and parts are in place, in order to keep smooth progress of installation.

4.5.1 Tower crane installation at the construction site should comply with the following points, confirmed by relevant supervision departments or personnel:

- a) Any obstructions at tower crane running area (such as: buildings, trees, cables, etc.);
- b) Whether concrete foundation, counterweight and ballast meet the technical requirements;

- c) Whether concrete foundation, counterweight and ballast meet the strength requirements;
- d) Whether crane equipment meets the installation requirements;
- e) Whether safety device and limiters of crane equipment are sensitive and reliable;
- f) Whether electrical connection of tower crane is reliable and effective;
- g) Focus on inspection of spreader of lifting equipment (such as: lifting hooks, lifting chain, rope, etc.).

 **Caution**

**1. Relevant supervision departments or personnel should disclosure to installation operator about lifting equipment for installation of tower crane mechanism and lifting weight.**

**2. Installation operators are responsible for tower crane lifting equipment to deal with the various operating tests, and the lifting safety components.**

**Specific mechanisms and lifting weight parts is shown in Chapter 5 of this manual about Tower Crane Installation.**

#### 4.6 塔机安装队伍与作业人员的条件

**4.6.1** 塔机的操作必须是经培训合格具有资质的人员进行作业。

**4.6.2** 塔机的操作人员经授权仅服从以下描述的指令进行作业：

- a) 当塔机在作业过程中，将执行起升、变幅、回转等组合动作时，操作人员应根据所吊的载荷。安全有效地控制组合动作的可行性；
- b) 操作人员在塔机运行过程中，应密切关注所吊的载荷的运行路径。在确认有安全威胁的场合下，应取得现场指挥/监督通过语言/手势等相关安全信号的帮助；
- c) 为正确使用塔机，操作人员应遵守本使用说明书第 8 章维护保养的规程，定期检查塔机各系统、机构，并做好塔机的维护保养工作；
- d) 在塔机的维护保养工作中，应使用原装配件或制造商指定的配件；
- e) 除塔机本身以外，在施工场地使用与塔机配套的机具（如：料斗、输送带等），应符合塔机的正确使用。
- f) 在塔机的运行过程中，操作人员应遵守国家 and 地方的塔机安全法律、法规。

安装期间的风速间本使用说明书第 5 章塔机安装。

#### 4.6 Tower crane installation and operating personnel team

##### 4.6.1 Tower crane operators must be qualified personnel.

4.6.2 Tower crane operator must be authorized only to obey the command operations described below:

- a) During operation of hoisting, luffing, slewing and others, the operator should control the combined action of feasibility effectively in accordance with the load suspended;
- b) Operator should pay close attention to the running path of the load hanging during operation. In the case of recognized security threat, operator should turn to safety signals or language / gestures for direct / supervise.
- c) For the proper use of tower crane, the operator shall comply with Chapter 8 of this manual and do good maintenance and inspection;
- d) In the tower crane maintenance, you should use original parts or specified accessories by the manufacturer;
- e) In addition to the tower crane itself, use supporting equipment rightly at construction site (such as: hoppers, conveyor belts, etc. ).
- f) The operator shall comply with national and local tower crane safety laws and regulations during tower crane operation.

The wind force during installation is shown in Chapter 5 of this manual.

#### 4.7 安全警示标识

- a) 在恶劣的天气下不得进行塔机的任何作业；
- b) 作业前，操作人员应具有良好的心理状态。并佩带使用合格的安全防护用品；
- c) 必须带安全帽；
- d) 必须系完好合格的安全带；
- e) 必须穿事故防护鞋；
- f) 必须使用绝缘工具；
- g) 在地面组装完毕，被雨水或其他水浸湿的部件或杆件，不得进行塔机高空组装；
- h) 为确保人员和物品的安全，塔机安装现场应设置警戒区，并确保未经许可人

员不得进入作业区域内。

#### **4.7 Safety Warning Labels**

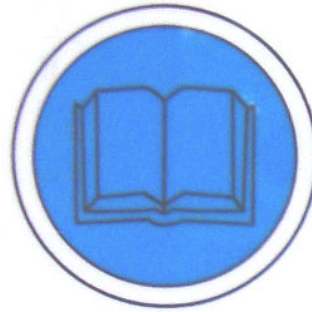
- a) No any operations in inclement weather;
- b) Before operation, the operator should have a good mental state, with qualified safety wear protective equipment;
- c) Must wear helmets;
- d) Must wear seat belt system;
- e) Must wear protective footwear;
- f) Must use insulated tools;
- g) Assembled on the ground, components or rod being soaked by rain or other water shall not be carried out aerial tower assembly;
- h) To ensure the safety of personnel and goods, tower crane installation site should be set to alert area, and to ensure that unauthorized personnel cannot enter the work area.

## 安全警示标识

### Safety warning mark



严禁触摸带电部位防止触电  
Don't touch and beware of electric shock



操作前请阅读使用说明书定期维护保养  
Please read the Instruction before operating and  
keep regular maintenance and maintaining



开门前请关闭电源  
Shut-off the power before opening door!



非专业人员勿动  
Non-professionals do not move



当心吊物 Beware of hanging things



当心落物  
Beware of falling things



必须戴安全帽  
Must: Wear safety helmet



必须系安全带  
Must: in safety belt



必须戴防护手套  
Must: wear protective gloves



必须穿防护鞋  
Must: wear protective shoes



禁止攀登  
No climbing



当心坠落  
Beware of falling



当心电缆 Beware of cable



当心机械伤人  
Beware of machine



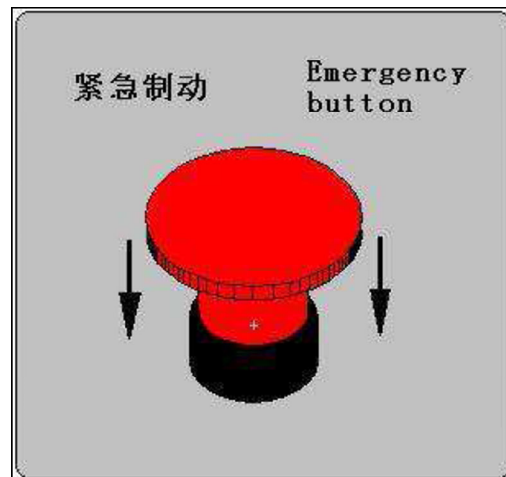
当心冒顶  
Beware of roof-falling



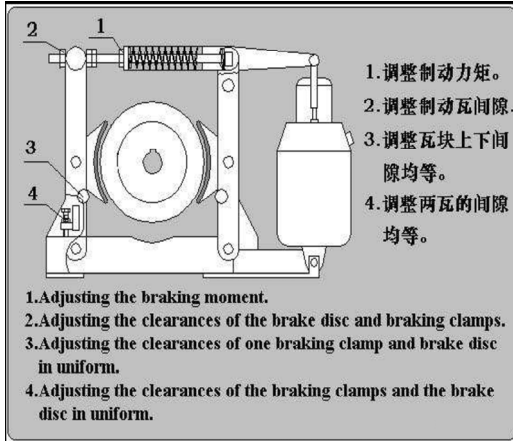
大臂下方禁止站人  
No people standing under arm.



非工作工况时回转自由  
Slewing freely out of service



急停开关  
Emergency button



调节制动器  
Adjusting brake



检查安全装置是否处于良好工作状态  
Check whether all safety devices have good working state.



注意重新调节各限位器!  
Readjust all stoppers!

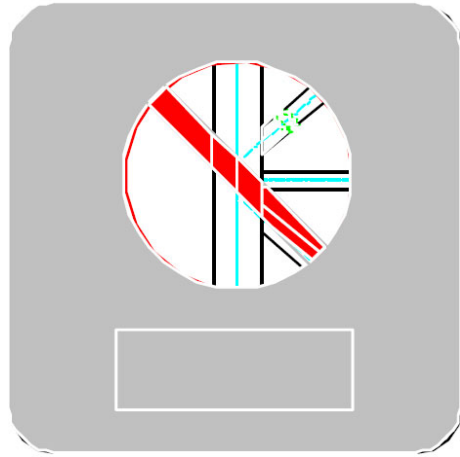


注意检查钢丝绳  
Check steel rope!



检查制动器的间隙和效能：  
每10个工作日一次。  
Check the brakes for  
performance and clearance  
every 10 days working.

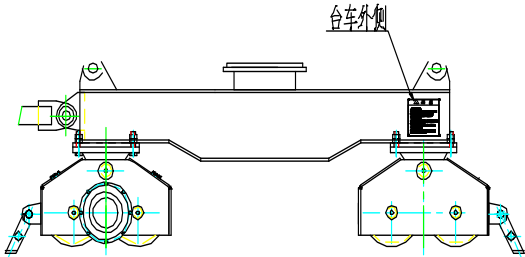
检查制动块的间隙!  
Check the brakes for clearance!



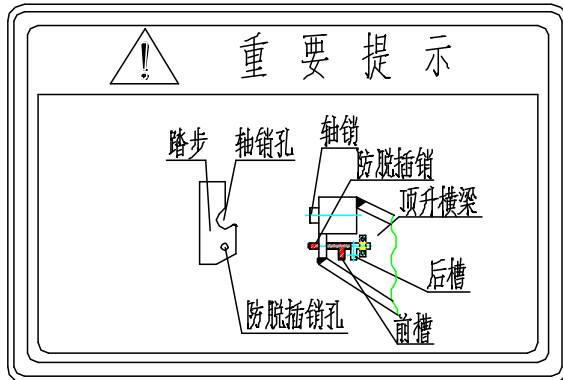
检查所有主要金属结构件的变形、焊缝情况，至少一周一次。

Check all main mental structural parts for deformation and welding seams at least once a week.

检查金属结构件!  
Check all mental structural parts!



- 1.塔机按指定位置（安全行程内）停车。
- 2.行走停稳后，辅助人员确保所有夹轨钳夹轨到位，并确保牢靠。
1. Stop tower crane in certain position (within safe range).
2. when stopping travelling firmly, operators should make sure all clamps of railway are positioned rightly and firmly.



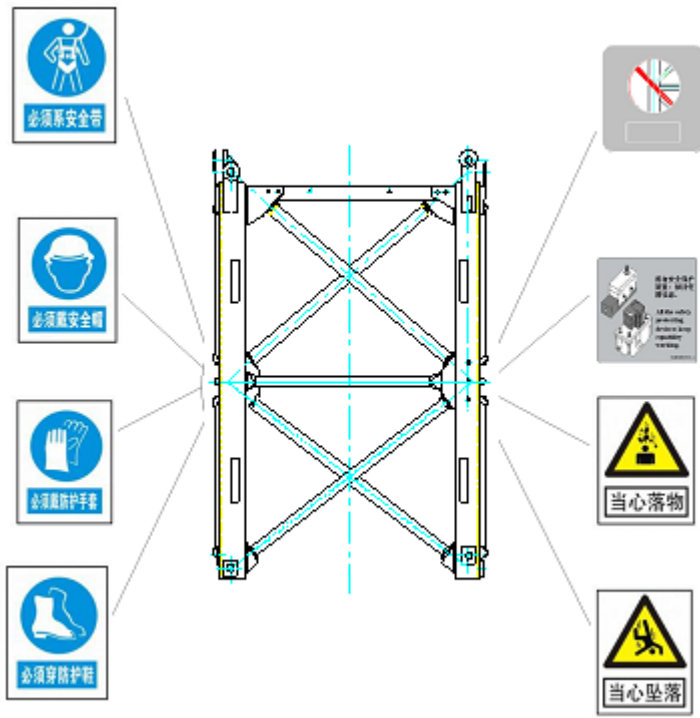
- 1.塔机在开始顶升加节或降塔减节时，须将顶升横梁的防脱销插入标准节的防脱销孔内，且固定在前槽内，并保证牢靠。
- 2.在完成一个顶升步骤，顶升横梁要脱离标准节踏步时，须先将防脱销轴退出标准节防脱销孔，固定在后槽内。

1. When increasing and decreasing masts of tower crane, insert the anti-out pins of jacking crossbeam

	<p>into its holes on mast and fix the pins in front groove firmly.</p> <p>2. After the completion of one jacking step, remove the anti-out pins out of its holes on mast and fix in rear groove when jacking beam is going to be removed from mast step.</p>
<div data-bbox="304 779 742 1227" data-label="Image"> </div> <p>1. 高强度连接螺栓应定期检查预紧扭矩防松, 在第一次安装后塔机使用 100 小时之时应普遍地均匀地检查拧紧, 以后每工作 500 小时均应检查一次。</p> <p>2. 在检查中如发现螺母、螺栓松动应立即拧紧。如有螺纹部分损伤必须更换。</p> <p>1. High-strength connecting bolt should be checked regularly avoiding becoming loose. After being used 100 hours, all bolts should be tightened again. Check the bolts condition after working every 500 hours.</p> <p>2. Tighten the loose nuts and bolts, and change the damages ones.</p>	<div data-bbox="874 801 1390 1294" data-label="Image"> </div> <p>注意定期加润滑油!</p> <p>Add oil regularly!</p>

各种安全警示标识及其标志位置如下:

The positions of all kinds of safety and warning mark are as follow:



基础节处安全标识位置图

Safety mark about basic mast



塔机安装	第五章
5.1 安装注意事项	5-3
5.2 塔机安装	5-8
5.2.1 安装前的准备	5-8
5.2.2 安装步骤	5-10
5.2.3 主要销轴规格	5-11
Tower crane installation	Chapter 5
5.1 Announcements	5-3
5.2 Tower crane installation	5-8
5.2.1 Preparations before installation	5-8
5.2.2 Installation procedures	5-10
5.2.3 The main pin shaft specifications	5-11

## 5.1 安装注意事项

5.1.1 塔机上所有的螺栓连接件都属于塔机的部件，对塔机的安全运行起到非常重要的作用，尤其是高强度螺栓连接件的连接应特别注意。

- 非扭力扳手拧紧的螺栓连接件

这类螺栓连接件是指扳手手动拧紧的。在塔机的运行过程中，这类螺栓连接件的松动，将会引起塔机的损坏或导致事故的发生。因此对它们应定期检查，以确保紧固而不至于松动。

- 扭力扳下拧紧的高强度螺栓连接件

这类高强度螺栓连接件包括螺栓、螺母、垫圈都是用高强度材料制造的，且按相同的等级配套。因此这类高强度螺栓连接件，在连接紧固时，应达到规定的拧紧力矩。用户应配备符合拧紧力矩的扭力扳手。

- 高强度螺栓连接件在塔机的使用位置

- a) 回转支撑；
- b) 塔机标准节；
- c) 起升机构、回转机构、变幅机构等驱动机构上。

## 5.1 Installation Considerations

5.1.1 All bolt and connection parts belong to tower crane and play a very important role for safe operation of tower cranes, especially high strength bolts connection.

- Non-torque wrench to tighten bolt connection parts

Such bolt connections are tightened by wrench. During operation of tower crane, the kind of loose bolt connections will cause damage to tower machine or cause an accident. Therefore, they should be checked regularly.

- Remove the tightened bolts connecting pieces

Such high strength bolt connections include bolts, nuts, washers which are all made of high-strength materials, having the same level of support. So this kind of high strength bolt connections during being connected should reach the tightening torque requirements. Users should equip with torque wrenches with tightening torque.

- High strength bolt connections are used in the such position

- a) Slewing bearing;
- b) Tower mast
- c) Lifting mechanism, slewing and luffing mechanism etc..

### 5.1.2 螺栓连接件的标识

塔机上所用的螺栓连接件(包括普通螺栓连接件和高强度螺栓连接件), 其材质和识别是按国际/国家标准的规定分类标识的。

### 5.1.3 螺栓: 按国际标准(ISO898)的规定: 螺栓的性能等级标识(如: 8.8、10.9、12.9等), 必须打印螺栓的六角端面。

螺栓必须标上制造厂商的原始标志, 这类原始标志的标识在六角端面靠性能等级标识的部位。

### 5.1.4 螺母: 按国际标准(ISO898)中的第 2 部分规定: 螺母的性能等级标识(如: 8、10、12 等), 必须打印螺母的六角侧面。对于高强螺栓里连接件的螺母也必须有螺母制造商的原始标志, 此原始标志的标识在六角侧面靠性能等级标识的部位。

当进行螺母配套选择时, 应确保其强度、性能等级与螺栓同等级别如:



螺母 8 —— 螺栓 8.8

螺母 10 —— 螺栓 10.9

螺母 12 —— 螺栓 12.9

### 5.1.2 Bolt connection parts labels

Bolts used on a tower crane (including ordinary and high-strength bolt connectors), its material is identified and classified in accordance with international and national standards and requirements.

### 5.1.3 Bolt: according to international standards (ISO898): performance class identity of bolts (e.g.: 8.8, 10.9, 12.9, etc. ) must be printed on hexagonal face of bolt.

Bolts must be marked with the manufacturer's original logo, which is at the hexagonal face of the logo.

### 5.1.4 Nut: according to Part 2 in international standards (ISO898) provisions: Nuts performance level identification ( e.g. : 8,10,12 , etc. ), must be printed hexagon side of

nut. For nut of high-strength bolts must also have the manufacturer's original logo, which at the same site of this primitive hexagonal logo.

In selection you should ensure its strength and performance levels at the same level of bolts, such as:



Nut 8 - Bolt 8.8

Nuts 10 - Bolts 10.9

Nut 12 - Bolts 12.9

### 5.1.5 垫圈：高强度螺栓连接件配套生产。

只有用高强度材料制造的垫圈才可以用于高强度螺栓连接件上。该材料生产的垫圈必须符合“螺栓、螺母”条文中列出的材料。制造商建议仅使用本公司配套使用的生产厂家的垫圈。对于用户使用其他厂商生产的垫圈，应确保其性能等级与配套的螺栓螺母的性能等级同等级别。



使用的垫圈必须是一面倒角，因此，倒角必须朝向螺栓头部。



注意：对于有些高强度螺栓连接件，因结构原因需要定距套，请向制造商联系咨询提供货源，同时按本使用说明书的规定进行安装。

### 5.1.6 螺栓连接件的检查

所有螺栓连接件在安装前应清理和目测检查（目测检查包括螺栓、螺母的螺纹；螺栓头部的支撑面等）。



损坏或损坏标志的螺栓螺母、腐蚀的螺栓及锈蚀的螺母都不得使用。

#### 5.1.6.1 螺栓连接件的润滑

所有的螺栓连接件的螺栓、螺母和垫圈在安装前，应用二硫化钼基润滑脂润滑，以提供最小的拧紧摩擦阻力，使之确保螺栓连接的预紧力。



螺栓、螺母和垫圈的支撑面用二硫化钼基润滑脂润滑。



注意：对于用预紧的扭力施加在螺栓上，必须用二硫化钼基润滑脂润滑。

#### 5.1.5 Washer: supporting production with high strength bolts.

Only high-strength washer can only be used on high-strength bolts connecting pieces. The material of this washer must comply with the material requirements of "bolts and nuts" listed. It is recommended to use the supporting washer of our company. For other manufacturer's washers, you should ensure that it is at the same level with the supporting bolts and nuts.



**Washer used must be one-sided chamfer, therefore, chamfer must face to the bolt head.**



**For some high strength bolt connection parts, due to structural reasons, if there are some needs to order distance sleeve, please consult the manufacturer for supply, while installing according to the provisions of this manual.**

#### 5.1.6 Check the bolt parts

All bolt connection parts should be cleaned and visually inspected before installation (visual inspection includes bolts, nuts, thread, bolt head bearing surface, etc. ).



**Bolts of corrupted or damaged signs and nuts or the rusted one are not allowed to use.**

##### 5.1.6.1 Bolt connection part lubrication

All bolt connection parts, nuts and washers, before installation, should be lubricated with molybdenum disulfide grease to provide minimal tightening friction to ensure preload force.



**Bolts, nuts and washers support surface also need to be lubricated with molybdenum disulfide grease.**



**Caution**

**For preloaded bolt, you must conduct molybdenum disulfide grease lubrication.**

### 5.1.6.2 螺栓连接件的反复使用

在塔机安装时，所有的螺栓连接件是按照规定的顶紧力紧固的，则在后次塔机安装时可继续使用，但要按照第 5.1.6 条规定节进行检查确认。

### 5.1.7 螺栓连接件的预紧力

螺栓连接件的预紧力是非常重要的，只有用正确的预紧力拧紧的部件，才能确保塔机正常安全地工作。同时螺栓的使用寿命取决于施加的正确扭矩和所能承受规定的预紧力，预紧力过高、过低都将导致螺栓连接件过早失效。

**5.1.7.1 预紧力：**为了达到螺栓连接件规定的预紧力，本使用说明书内附有螺栓的扭力表。用户在进行螺栓连接件安装工作时，应根据所安装的不同规格螺栓连接件，使用扭力扳手施加不同的扭力矩予以紧固。

注：此力表的质量等级是按 ISO 898 第 1 部分和第 2 部分为依据。

### 5.1.6.2 Repeated use of bolt connection parts

During installing the tower, all bolt connection parts is fastened in accordance with the provisions, may continue to be used when the second tower installation, checking it according to the provisions of section 5.1.6.

### 5.1.7 Preload

Preload of bolt connection parts are very important to ensure the normal tower crane work safely. Meanwhile the bolt life depends on the correct applied preload on it. Being too high or too low will cause premature failure of the bolt connection.

**5.1.7.1 Preload:** In order to achieve preload required, this manual is attached a bolt torque table. During installation bolts user should do the different fastening based on different specifications of bolt connection parts using a torque wrench.

Note: The quality level of this table is based on ISO 898 Part 1 and Part 2.



未经润滑的螺栓在任何情况下都不能用在高强度预紧螺栓连接件上。

**5.1.7.2 扭力扳手：**此类扳手应具有设定扭力的大小和紧固方向的功能。扭力扳手只能施加规定的力矩，如需更大的扭矩，可使用动力驱动的倍增器（最大扭矩可达到 9500N.m），也可使用液压扭力扳手。当使用液压扭力扳手时，压力计应显示液压系统的压力，对照压力计的压力施加规定的扭力矩(压力计和扭力矩的关系式可查阅相关的表式)。在使用各种扭力扳手前，应进行检查与调整。

**Warning****Bolts without lubrication can't be used on high-strength bolting parts.**

**5.1.7.2 Torque wrench:** Such torque wrench should have the function of setting size and fastening direction. It can only apply at the specified torque, for more torque using power-driven multiplier (Maximum torque up to 9500N.m). You can also use hydraulic torque wrenches. When using hydraulic torque wrenches, pressure gauge shows the hydraulic system pressure, so you can apply torque depending on the numbers on manometer ( pressure gauges and torque relation can be found in associated tabular ). Before using torque wrenches, you need to check and adjust it.

**警告**

**拧紧扭力矩的误差必须控制在±10%以内**

**5.1.8 安装螺栓连接件的检查**

**5.1.8.1** 任何螺栓连接件都会松动。对于高强度预紧螺栓连接件的连接松动，会导致预紧力完全或部分丧失，从而导致螺栓材料过早疲劳，并有疲劳断裂的危险。另外接点不协调，连接也会引起松动。

**5.1.8.2 安装完毕螺栓连接件的初次检查和重复检查**

初次检查

由于新塔机及其机构、部件是用螺栓连接件的连接所决定的，因此所有经安装的螺栓连接件初次检查在首次安装完成后的三周内进行。检查时应使用相同的扭力扳手或倍增器，参照相关的额定扭力矩表，对螺栓连接件进行重新拧紧。如果螺栓还能拧紧，则必须将原连接完全松开，重新进行润滑并施加规定的扭力矩进行紧固，反之不能再拧紧，则表示连接已符合要求。

**重复检查：**螺栓连接件在塔机重新安装前，应按第 5.1.6 条的规定进行重复检查、确认。

目测重复检查：目测重复检查应三个月进行一次。目测各螺栓连接件的连接应无间隙，否则表示连接已经松动，应重新紧固。

螺栓连接件的更换

对于机构、部件在同一连接水平面上的螺栓连接件发现多处螺栓还能拧紧，则表示塔机机构、部件星湖连接的部位（如：塔身节、回转支承等）将出现螺栓的损坏或断裂，因此对于此类现象，同一连接水平面上的螺栓必须全部更换。



螺栓连接件的事故防范

对于第 5.1.6 到第 5.1.8 的所有条文，用户应严格的遵守并作好 定期检查，这是确保塔机安全运行、防范事故发生的必要程序。

#### 5.1.9 扳手尺寸十字平头

螺栓、配套螺母。扳手的使用应比配套的螺栓、螺母尺寸稍大的扳手。



**The tightening torque must be controlled within an error  $\pm 10\%$ .**

#### 5.1.8 Check the bolt connection installation

**5.1.8.1** Any bolt connections may be loose. Loose connections of high strength bolt will cause complete or partial loss of preload, resulting in bolt material premature fatigue, with the risk of fatigue fracture. Besides, uncoordinated contacts may also cause loose connection.

#### 5.1.8.2 Initial inspection and repeat inspection for installed bolt connections

Initial inspection

Since the new tower and its mechanisms, component parts are bolted connection, so all bolted connections initial inspection is carried out within three weeks of completing first installation. Check the torque wrench and retighten bolt connection in reference to the relevant rated torque table. If you can tighten the bolts, the original connection must be completely released, re-lubricated and applied fastening torque. If it can't be tightened, the connection meets the requirements.

Repeat inspection: bolting machine before reinstalling the tower shall be checked repeatedly, as the provisions of Article 5.1.6.

Repeated visual inspection: visual inspection should be repeated once for three

months. Inspect that there shall not be the clearance of bolt connection. Otherwise the connection should be retightened.

Replace the bolt connecting member

For the same level bolt connection of mechanisms and parts, if many connections are founded to be able to be tightened, that means the bolts tends to be damaged or fractured. So for such phenomena, bolt connection parts at the same horizontal plane must all be replaced.



**Warning**

#### **Accident prevention**

**For all the provisions of section 5.1.6 to 5.1.8, the user should strictly observe and prepare regular inspection, which is to ensure the safe operation of tower crane, and to prevent accidents.**

#### **5.1.9 Wrench size cross flathead**

Bolt and its matching nut: the size of required wrench needs to be slightly larger than the bolts and nuts'.

#### **5.1.10 螺栓连接件的扭力表**

螺栓连接件的扭力矩间下表（见下页）：

#### **5.1.10 Bolting torque table**

The torque table of bolted connection in the below (see next page):

螺纹 Thread	性能等级 Performance level		性能等级 Performance level				性能等级 Performance level	
	8.8 8		10.9		10		12.9	12
	mkg	Nm	mkg	Nm	mkg	Nm	mkg	Nm
M 12	5.2	61	9.8	96	7.4	73		
M 14	8.4	82			13.0	127		
M16	14.0	137	24.7	242	19.1	187		
M18	18.0	177			26.0	255		
M20	25.9	254	48.3	474	37.0	363		
M 22	35.8	351	66.0	647	51.1	501		
M 24	44.9	439	83.0	814	84.0	828		
M 27	70.0	686	123.0	1206	100.0	981		
M30	96.8	939			136.8	1342		
M33	130.9	1284			187.0	1834	230.8	2264
M36	167.3	1641			239.0	2344	296.1	2904
M39	217.3	2131			310.4	3044	383.6	3782
M42	268.4	2632			383.4	3760	476.3	4670
M45	335.4	3289			479.1	4693	594.8	5833
M48	403.6	3958			576.6	5655	717.8	7039
M56					900.0	8830		

## 5.2 塔机安装

### 安装总则

- 1、使用汽车吊安装塔机时必须注意安全，为此：
    - 1) 汽车吊支腿牢固可靠
    - 2) 严禁超载
    - 3) 吊具良好。按被吊物的重量选择正确的幅度
    - 4) 吊点位置正确
  - 2、安装作业必须按说明顺序进行
  - 3、必须安装并使用安全防护措施，如爬梯、平台、护栏、安全带等
  - 4、平衡臂上未装配重时，严禁吊载
  - 5、风速超过 **13m/s** 时，严禁顶升作业
  - 6、顶升作业前，必须用销轴连接好回转支承和顶升套架，并加开口销
  - 7、必须根据起重臂长度确定配重数量（见相应章节）
  - 8、顶升前，须将起重臂转至顶升套架开口处（即引入塔身标准节的一侧）
  - 9、起吊或落下标准节时，要尽可能地靠近塔身
  - 10、塔机顶升过程中，严禁旋转起重臂、开动载重小车及使用吊钩升降
- 本总则适用于塔机的安装、加节、拆卸作业。

### 5.2 Tower crane installation

#### Installation principles

1. Care must be taken when installing car crane tower crane safety, so:
  - 1) Solid and reliable truck crane anchor leg
  - 2) No overload
  - 3) Good spreader and correct magnitude for lifting weight
  - 4) Correct lifting position
2. Do installation as the order in Instruction.
3. You must install and use security measures, such as ladders, platforms, guardrails, safety belts, etc.
4. No lifting operation when no counterweight is on counter jib.
5. No jacking operation when the wind speed exceeds 12m/s.
6. Connect and fix slewing bearing and telescoping frame before jacking by pin shafts

and cotter pins.

7. Decide counterweight quantity depending on jib length.
8. Before jacking, turn jib towards telescoping opening.
9. Close the masts as near as possibly when lifting or dropping.
10. No rotating jib and moving trolley and hook during jacking operation.

The general principles are applicable to the installation, adding-mast, and removal of the tower crane.

## 5.2.1 安装前的准备

### 5.2.1.1 详细阅读本说明，熟悉塔机安装程序和注意事项。

了解安装现场的条件，制定相应的安装工艺。对现场的土质、地下暗沟、涵洞等影响汽车吊装作业的问题要有相应的处理措施。在塔机最大回转半径内应没有空中障碍物，对高压线要保持一定的安全距离。

起重机安装单位和人员必须持有安装许可证和安装操作上岗证，严禁无证单位、无证人员安装起重机，否则，造成一切后果，自行负责。适合的气象条件。在大风、雨雪、浓雾等不适宜作业的条件下，应考虑停止安装、拆卸作业。如果须在夜间进行安装、拆卸工作，工作现场应有充足、合理的照明。

应有符合塔机供电要求的供电系统和单独的、且可以使用的电源箱。

对进入场地的塔机零、部件进行清点，以防在塔机安装过程中因缺少零件而造成塔机安装工作中途停顿，影响塔机安装工作的顺利进行。

## 5.2.1 Preparation before Mounting

### 5.2.1.1 Reading the specification carefully and familiar with the process and items needing attention.

Recognize the site layout and make the correspondent mounting plan. Take measurement to the soil condition, the secret trench underground and culvert. Clear away the obstacles in the slewing range of the tower crane. Keep the safe distance from the high-voltage wire.

The unit and personnel in charge of mounting of the tower crane must have the mounting license and operation certificate. It is forbidden for the unit with no license or the personnel with no certificate to mount the tower crane. Otherwise be responsible for all the consequence.

Good weather condition. When in the windy, raining, snow and foggy condition, the

assembling and disassembling should be stopped. Make sure the sufficient light when assembling and disassembling in night.

Supply properly, individual power supply box is needed.

Check each part and component of the crane; avoid any intermission of assembling caused by shortage of parts.

#### 5.2.1.2 塔机安装所需的设备和工具：

- 1、符合要求的辅助吊车一台。
- 2、索具、卡具
- 3、工具：
  - 1) 10 磅大锤 4 把，4 磅锤 2 把，2 磅锤 2 把。
  - 2) 30、32、36、41、梅花搬手各两把，15"、12"、10"、8"活搬手各两把。
  - 3) 撬棍，长度 1 米、0.4 米各两根。
- 4、电工工具一套（包括万用表、兆欧表）。
- 5、手拉葫芦一个。
- 6、尼龙绳
- 7、50 米卷尺一个。
- 8、手虎钳一把。
- 9、8#铅丝若干。
- 10、道轨枕木、10×10×30 木方若干备用。

#### 5.2.1.2 Equipment and tools for installment:

1. One needed truck crane.
2. Hangers and fastener
3. Tools:
  - 1) 4 hammers (10 pounds), 2 hammers (4 pounds), 2 hammer (2 pounds)
  - 2) 2 ring spanner(30, 32, 36, 41) , 2 wrench (15", 12", 10", 8")
  - 3) Crowbar: 1 meter and 0.4 meter, each kind need 2 sets.
  - 4) Electrician box (multimeter and megameter)
  - 5) Chain block
  - 6) Nylon rope
  - 7) tape measure (50m)

8) Pliers

9) Lead wire (8#)

10) Crosstie (10×10×30)

### 5.2.1.3 塔机基础的制作

用户和安装单位根据建筑物的布局决定基础的铺设位置，按基础图上所规定的技术要求进行基础制作。

#### 5.2.1.3.1 基础的选择

基础的选择是根据塔机使用的最终高度和现场地耐力状况确定的。基础图中对地耐力要求作出了明确的规定

#### 5.2.1.3.2 固定支腿的安装

固定支腿安装不恰当会使塔机出现严重事故，如标准节不垂直、变形等。固定支腿的安装按照下述说明进行：

- 1、固定支腿必须按混凝土块中心线对称安装；
- 2、注意固定支腿鱼尾板的安装尺寸（见图中 150mm 尺寸）；
- 3、注意接地线的安装应正确；
- 4、将固定框架与固定支腿用 8 个  $\phi 65 \times 194$  的销轴连接，再将固定框架和固定支腿安放在混凝土的加强钢筋件上，并用斜楔调整固定支腿底板；将一节标准节与固定框架用 8 个  $\phi 55 \times 171$  (180) 的销轴连接；用一个铅垂线陀或水平仪从两个方向（x、y 方向）检查是否垂直。浇注混凝土，混凝土标号不低于 C35，待其完全干硬后，拆下固定框架和标准节。要求同一水平上的销轴孔的垂直误差小于 2mm。

**注意：**固定框架仅做埋设固定支腿用，在任何情况下，都不能在工作时用于支撑塔身。

### 5.2.1.3 Concrete base

The position of base can be chosen basing on the layout of building, and base should be made according to the foundation drawings.

#### 5.2.1.3.1 Choosing the position of foundation

Choose the foundation according to the height of crane and the ground endurance. In the drawings, there are clear requirements for the ground endurance.

#### 5.2.1.3.2 Fixed legs assembly

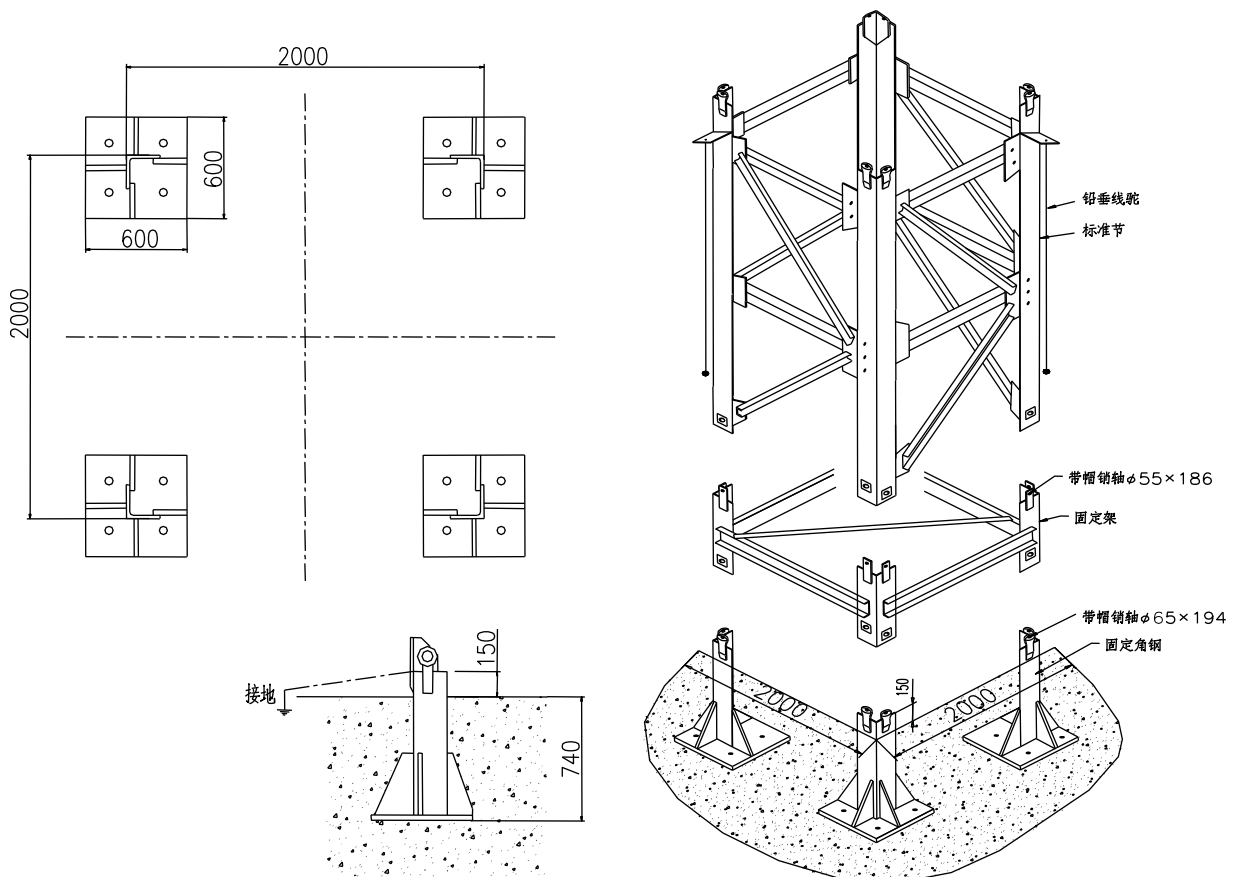
Incorrect assembly of legs will cause serious accidents, such as section bend or deformation. Please assemble the legs as follows:

1. According to the centre line of concrete assemble symmetrically.

2. Pay attention to the installation size of outrigger fishplate.
3. Note that the ground wire should be properly installed;
4. Connect the fixed frame with the fixed outrigger by eight  $\phi 65 \times 194$  pin shafts, and then put the unit on strengthening steel bars of concrete, adjusting outrigger base plate by diagonal wedge. Fix one mast on fixed outrigger using eight  $\phi 55 \times 171$  (180) pin shafts, checking its two directions (X and Y) vertical or not using a plumb or gradienter. Pour the concrete and the level of concrete is not less than C35. After the concrete has been dry completely, remove the fixed frame and mast. The vertical error of pin shaft holes at the same level is smaller than 2mm.



**Caution** Fixed frame is only used for embedding outrigger. In any case, it can't be used to support tower body.



## 5.2.2 安装步骤

独立固定式工作时，起升高度为 60m，自下而上的组成为：1 节基础节 17 节标准节，特殊节，下支座和上面回转部分。

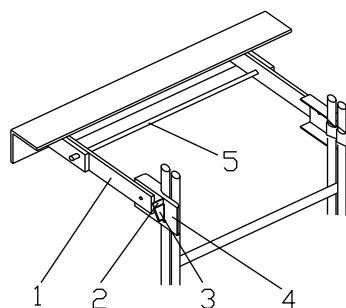
### 5.2.2.1 安装基础节

#### 5.2.2.1.1 安装爬梯

基础节爬梯由两节组成，具体见图

基础节爬梯的安装，从基础节下端开始安装 4.5 米爬梯。并用销轴  $\phi 10 \times 393.5$  (405.5) 将梯子联接架安装到基础节梯子联接架座上，两端用

$\phi 3 \times 30$  开口销固定（见右图）。将爬梯放在两个梯子固定板之间，把梯子固定钩 3 从爬梯两立柱中插入并穿过梯子固定板中方孔。将楔板 2 从梯子固定钩中打入，使楔板尾端向两侧弯曲。将 3 米爬梯插入已装好的 4.5 米爬梯中，用同样方法固定在基础节上。打开爬梯上护身圈。



1 - 梯子联接架 2 - 楔板  
3 - 梯子固定钩 4 - 梯子固定板 5 - 销轴  
1-Ladder connection frame 2-Wedge plate 3-Ladder fixing hook 4-Ladder fixing plate 5-Pin shaft

### 5.2.2 Procedure of Installation

During the operation of the independent fixed tower crane, the lifting height is 60m.

The components from bottom to up are: 1 transient mast , 17masts, special mast section, lower support and the slewing part above.

#### 5.2.2.1 Installation of transient mast

##### 5.2.2.1.1 Installation of mast

Ladder of transient mast consists of two parts, details in Figure.

The installation of transient mast ladder starts with installing 4.5m ladder from the bottom of transient mast. Fix the ladder connection frame on its seat on transient mast by pin shafts  $\phi 10 \times 393.5$  (405.5), with  $\phi 3 \times 30$  cotter pins at two ends (see the Figure). Place the ladder between two fixing plates of ladders and insert the ladder hook 3 through two cylinders of ladder and through the square holes on fixing plate. Penetrate the wedge plate 2 into ladder hook to bend the two sides of wedge plate. Mount the 3m ladder on the completed 4.5m one and fix it on transient mast at the same way. Mount the guard ring on ladder.

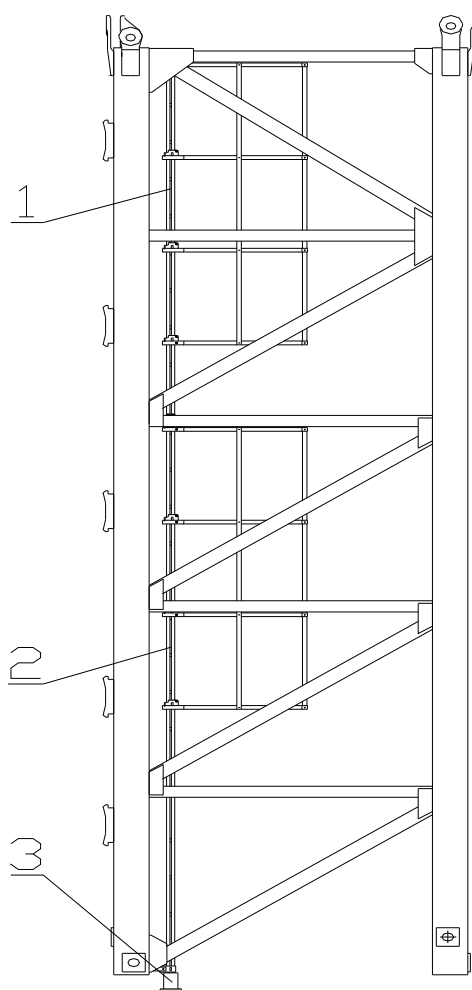
#### 5.2.2.1.2 安装基础节

将装好梯子的基础节吊装在砼基础上，与固定支腿鱼尾板用 8 个  $\phi 65 \times 164$  (194)

的带肩锥头销轴连接,并用  $\phi 20 \times 252$  的锁销和  $\phi 5 \times 36$  开口销固定,开口销充分打开。(注意基础节 I 上有踏步的一面要垂直于建筑物)。基础节 I 安装好以后,把梯子支架摆放在爬梯下端。如果高不合适可以垫以木板。

#### 5.2.2.1.2 Installing transient mast

Place the transient mast with complete ladder on concrete base and connect it with outrigger fishplate by eight  $\phi 65 \times 164$  (194) should pins, locking them with  $\phi 20 \times 252$  lock pins and  $\phi 5 \times 36$  fully-open cotter pins. (Note: the transient mast side with step is vertical to building). After installed the transient mast, put ladder frame under ladder. If its height is not enough, you can base wood plates.

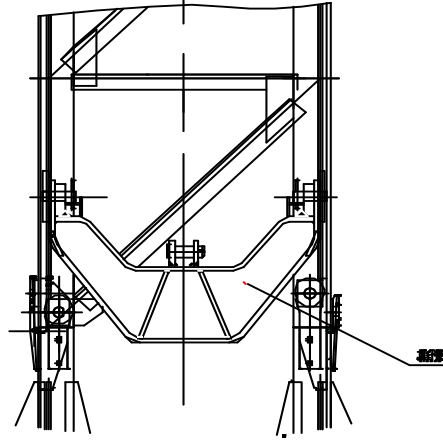


### 5.2.2.2 安装顶升梁

将顶升梁吊起至过渡节焊有顶升踏步一侧，用销轴将顶升梁与左、右踏步连接

### 5.2.2.2 Installing jacking beam

Hang up the jacking beam to the step side of transient mast and connect it with right and left steps by pin shafts.



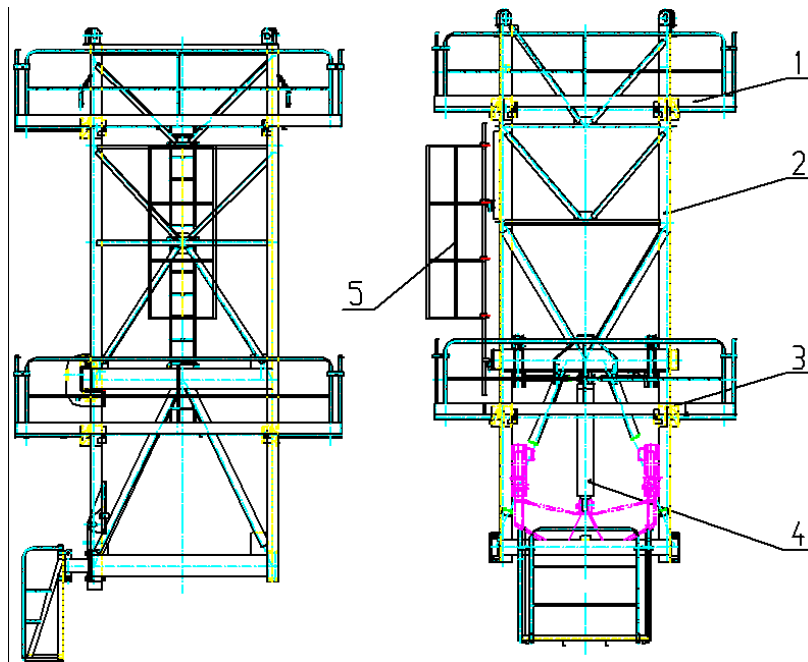
Jacking beam

### 5.2.2.3 安装爬升架

爬升架的装配包括安装套架平台、套架爬梯和顶升油缸，最后将爬升架整体吊装。

### 5.2.2.3 Installing climbing frame

Installation of climbing frame includes installation of frame platform, ladder, jacking oil cylinder. At last, mount the whole climbing frame unit.

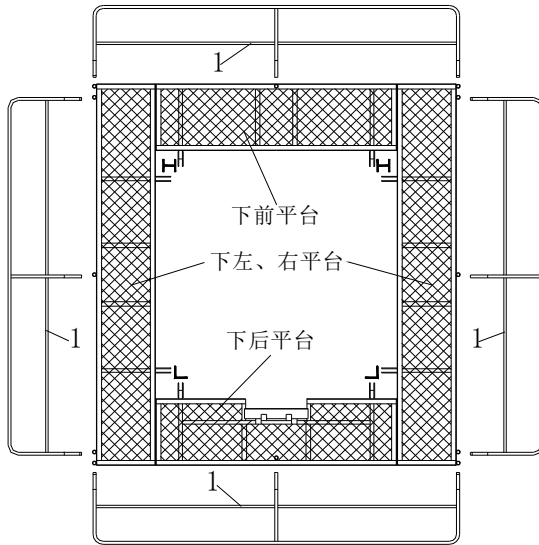


- 1 - 套架上平台 2 - 套架 3 - 套架下平台  
4 - 顶升油缸 5 - 套架爬梯

5.2.2.3.1 安装套架平台

套架平台共分上、下两层，具体安装位置见图 4-6。安装顺序是：

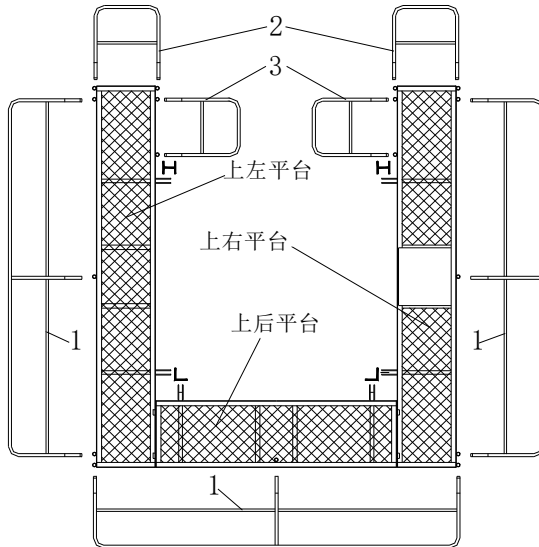
- 1、下层左、右平台
- 2、下层后平台
- 3、下层前平台
- 4、上层左平台
- 5、上层右平台
- 6、上层后平台



套架下层平台示意图

Front lower platform  
Left and right lower platform  
Rear lower platform

Lower platform of climbing frame



套架上层平台示意图

Left upper platform  
Right upper platform  
Rear upper platform

Upper platform of climbing frame

注：1、4米栏杆 2、0.69米栏杆 3、0.62米栏杆

Note: 1. 4m railing; 2. 0.69m railing; 3. 0.62m railing;

### 5.2.2.3.1 Installing frame platform

The frame has upper and lower two parts and the detailed installation position is shown in Fig 4-6. The installing order is:

1. Lower left and right platform
2. Lower rear platform
3. Lower front platform
4. Upper left platform
5. Upper right platform
6. Upper rear platform

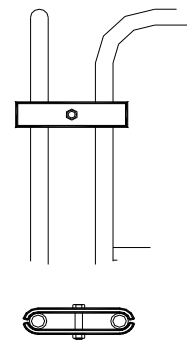
吊起平台使平台撑杆对准套架主肢上快装耳座，按图将平台安装完成。

Lift platform,the platform poles on the set or main limbs fast loading ear,according to the figure will platform installation



待平台安好以后再将栏杆装好并用栏杆夹板和 M14×65 螺栓固定，见图所示。

Stay platform well will later railings installed used rail splint and M14×65 bolted ,as shown in fig



### 5.2.2.3.2 安装套架爬梯

将套架爬梯立起在下层平台上，用梯子联接件按右图所示位置安装在套架上。具

体安装方法见安装过渡节部分

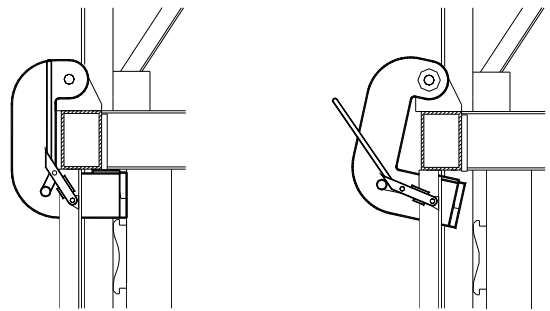
#### 5.2.2.3.3 安装顶升油缸

将顶升油缸吊至安装位置，用  $\phi 50 \times 135.5$  (188) 带肩锥头销轴和  $10 \times 80$  开口销固定，然后让油缸处于自然垂直状态。

#### 5.2.2.3.4 套架整体吊装

套架整体吊装前首先应将支承爬爪操纵杆向下搬动，使支承爬爪向后移动处于打开位置。这样在套架装入基础节时不会与基础节上顶升踏步发生干涉。支承爬爪打开后用操纵杆上锁圈把操纵杆搬手锁住。

从地面吊起顶升套架至已安装好的过渡节上方，转动顶升套架使顶升油缸处于顶升梁一侧（即基础节上有踏步的一侧），套架中心对准基础节中心徐徐下降，使顶升套架上下圈导轮与基础节外框对准。当顶升套架降至顶升油缸与顶升横梁接近时，用人力推动顶升油缸使其活塞杆上安装孔与顶升横梁上安装孔对正，用  $\phi 50 \times 165.5$  (218) 带肩锥头销轴和  $10 \times 80$  开口销固定。



关闭位置

Close position

打开位置

Open position

#### 5.2.2.3.2 Installing frame ladder

Erect the frame ladder on the lower platform and mount it on frame by ladder connection parts. The detailed method is shown in Installation of Transient Mast part.

#### 5.2.2.3.3. Mounting jacking oil cylinder

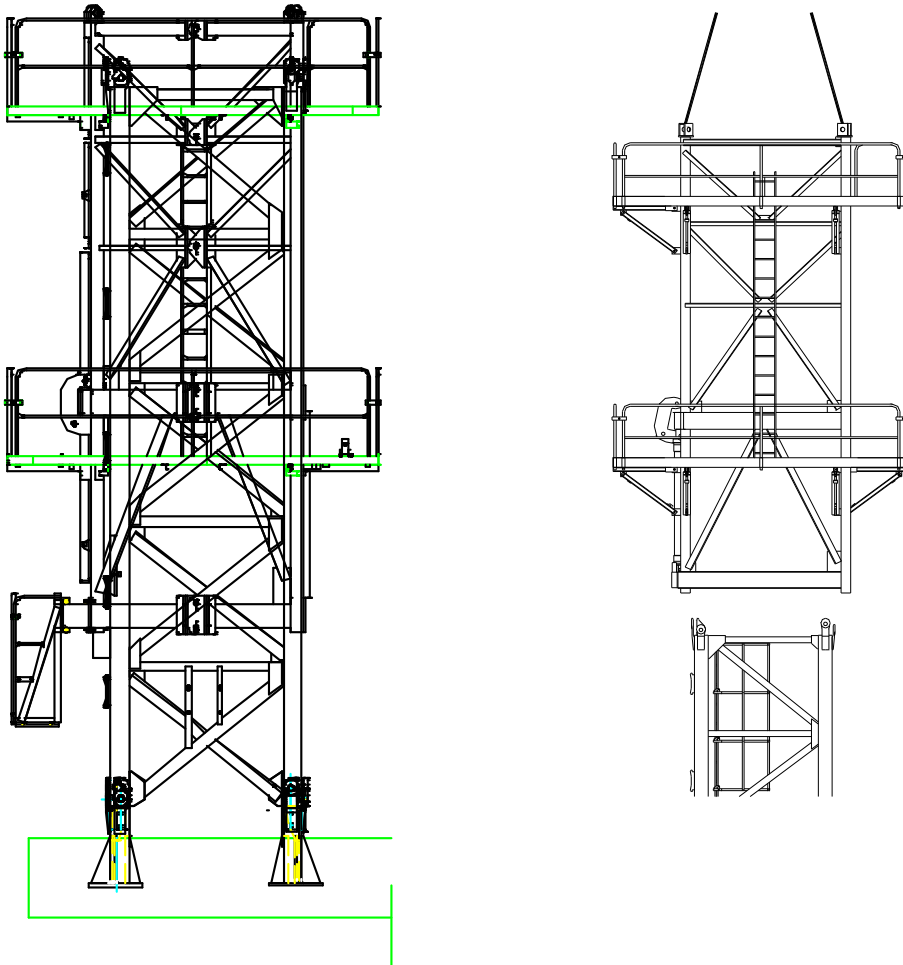
Suspend the oil cylinder to mounting position and fix with  $\phi 50 \times 135.5$  (188) shoulder cone pin shafts and  $10 \times 80$  cotter pins. And then keep oil cylinder at natural state.

#### 5.2.2.3.4 Mounting the whole frame unit

Before mounting the whole frame unit, move downward the bearing claw joystick to move bearing claw backward to the opening position. Thus, when inserting the frame into transient mast, avoid the interference with the jacking step on transient mast. Open the bearing claw and lock the joystick with its lock ring.

Lift up the telescoping frame from the ground beyond the mounted transient mast. Rotate the telescoping frame to let jacking oil cylinder at the jacking beam side (the step side of transient mast). Lower the frame aiming at the transient mast center to make its upper and lower guiding wheels align with the outer frame of transient mast. When the telescoping frame is

near to the oil cylinder and beam, push jacking oil cylinder to make the installation hole of its piston rod aim at the installation hole on the jacking beam. Later, fix them by  $\phi 50 \times 165.5$  (218) shoulder cone pin shafts and  $10 \times 80$  cotter pins.



#### 5.2.2.4 安装特殊节、回转支承单元

安装特殊节，用销轴分别与爬升架连接。然后将引进装置中的一根引进梁用人力抬入下支座下面，并将引进梁前端抬起用销轴和开口销固定，向下压下引进梁前端使引进梁后端抬起就位后，用销轴和开口销将引进梁后端固定。用同样方法安装另一引进梁。引进装置安好后，再将这一套部件吊起至已安装好的过渡节上方，使引进梁处于顶升套架开口方向，下降整套部件使回转下支座四条支脚插入过渡节鱼尾板内，打入八根 $\phi 55 \times 136.5$ （182）带肩锥头销轴和4根 $\phi 20 \times 183.5$ （252）锁销，装上5×36开口销，并将开口销充分打开。

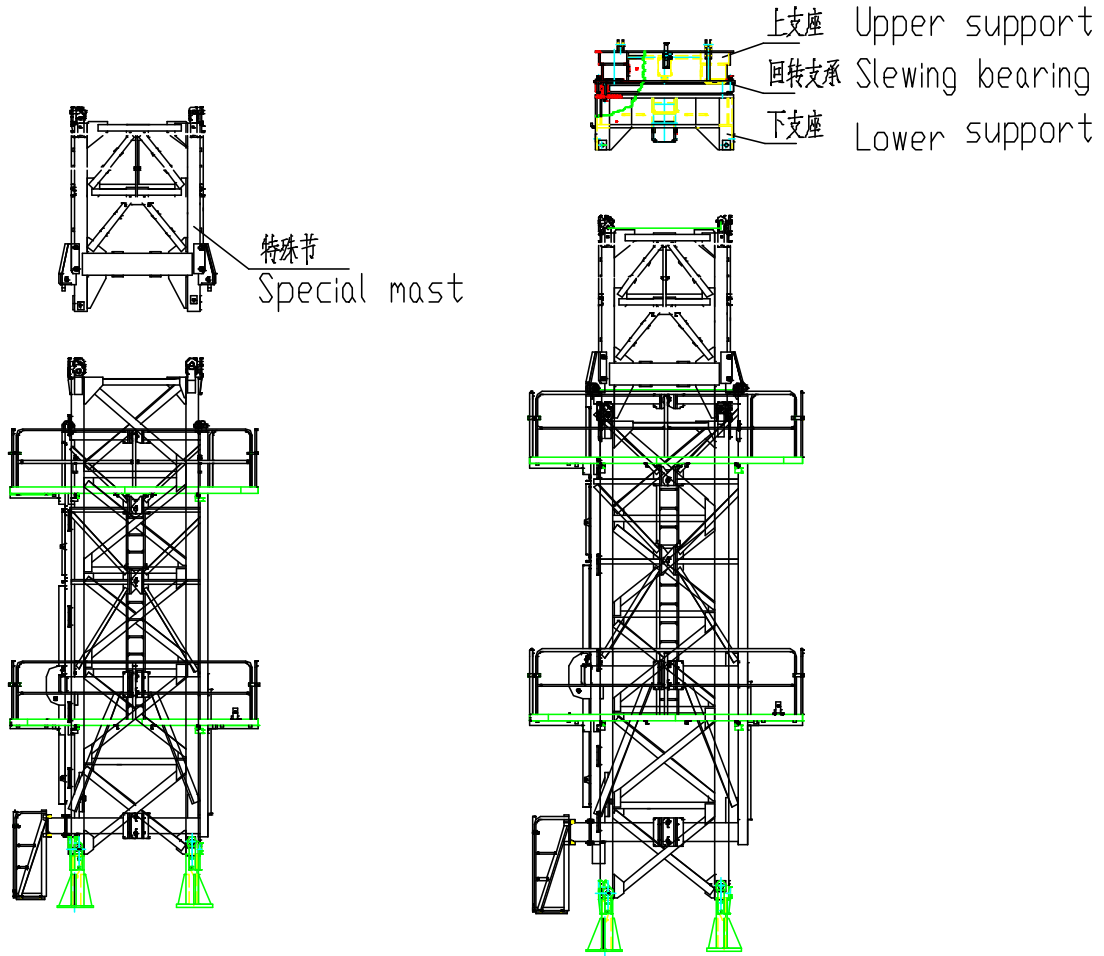
在地面上，先将上、下支座以及回转机构、回转支承、平台等装为一体，安装到特殊节上。

#### 5.2.2.4 Installation of special mast section and slewing bearing unit

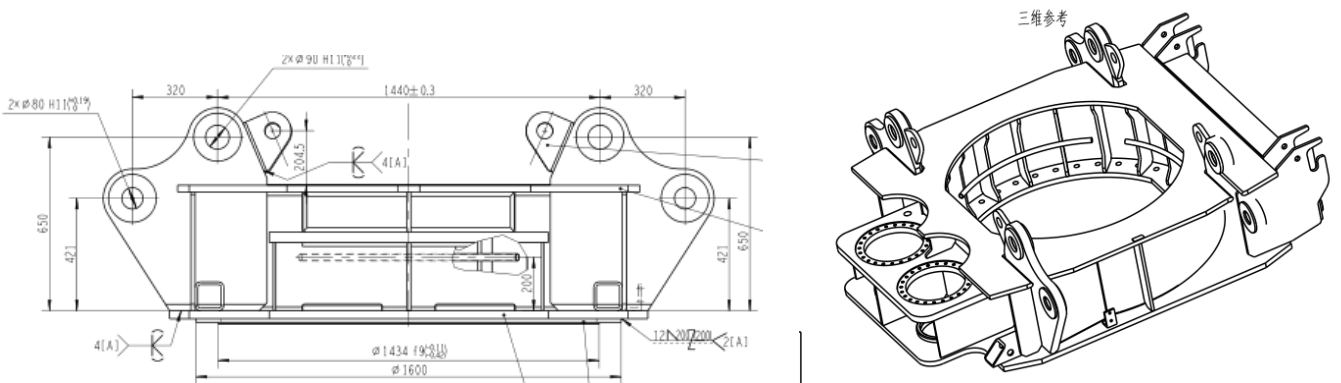
Mount the special mast section and connect it with climbing frame by pin shafts. And then raise one introduction beam of introduction device under the lower support. And then raise a little bit of the front end of introduction beam, fixing with pin shaft and cotter pins. Press the front end of the beam to position the rear end of the beam, fixing with pin shafts and cotter pins. Mount another introduction beam at the same way.

After its installation, lift up the introduction device on the mounted transient mast, keeping the introduction beam towards the opening of telescoping frame. Lower the whole frame part to insert the four outriggers of lower support into fishplate of transient mast. And then penetrate eight $\phi 55 \times 136.5$  (182) shoulder cone pins and four $\phi 20 \times 183.5$  (252) lock pins, with fully open 5×36 cotter pins,

On the ground, assemble the upper and lower support, slewing mechanism, slewing bearing and platform into one unit. After that, mount it on special mast section.



5.2.2.4.1 如下图所示，上支座。

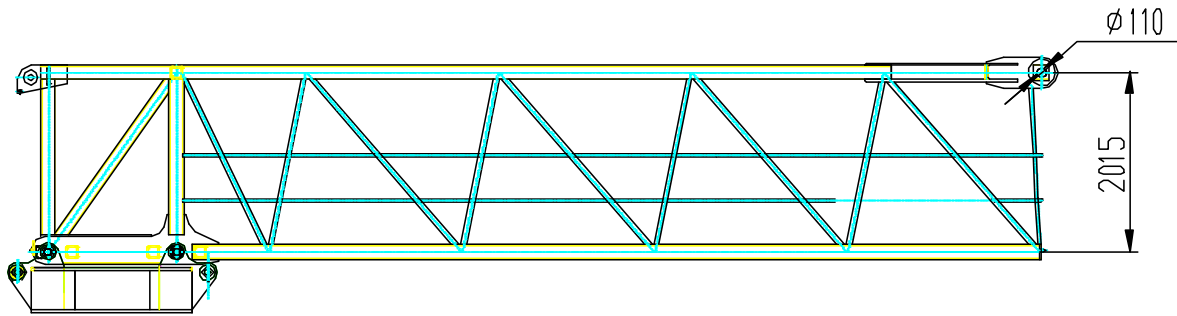


5.2.2.4.1 As shown in the figure below.

### 5.2.2.5 安装起重臂臂节一

5.2.2.5.1 在地面上组装好起重臂臂节一，起吊，下端与上支座用销轴连接。

#### 5.2.2.5 Installing jib 1



5.2.2.5.2 在地面上组装好起重臂臂节一，起吊，下端与上支座用销轴连接。

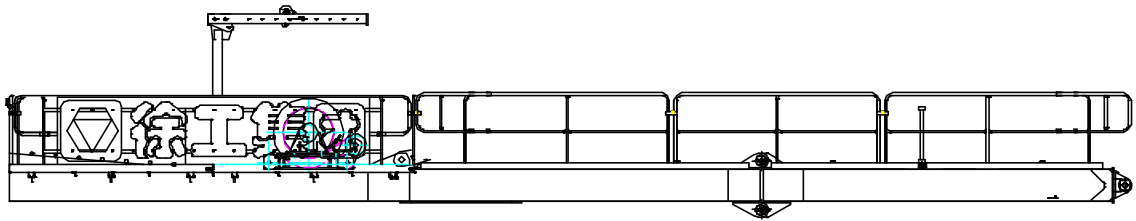
5.2.2.5.2 Assemble the jib 1 on the ground. And then lift it up and connect its bottom with upper support by pin shaft, and its top with counter jib.

### 5.2.2.6 安装平衡臂、平衡臂拉杆

组装平衡臂，在平地上拼装好平衡臂，并将起升机构、配电箱、电阻箱等装在平衡臂上，接好各部分所需的电线。

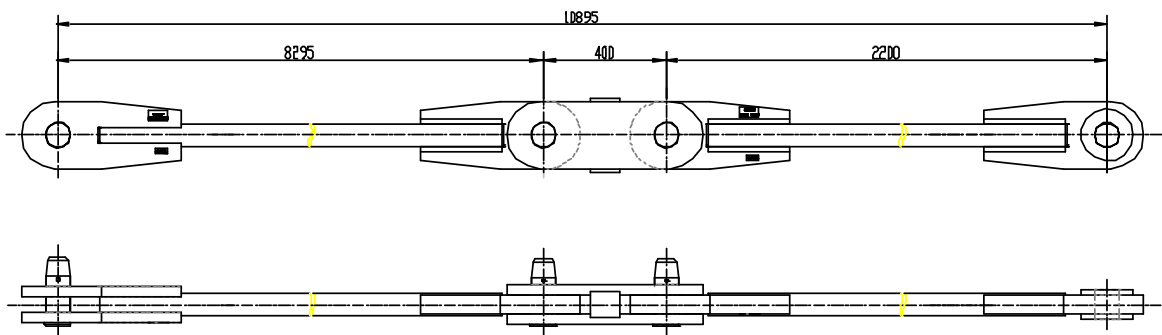
#### 5.2.2.6 Installing counter jib and its drag rod

Assemble the counter jib on the ground and mount lifting mechanism, distribution box, and resistance box on it. And then complete all the wire connections for each part.



平衡臂拉杆组成如下：

Correspondent counter jib drag rod is as below:



### 5.2.2.7 安装一块平衡重

安装一块 3.1t 平衡重，位置靠近起升机构旁边

### 5.2.2.8 安装起重臂

**5.2.2.8.1** 按照不同吊臂长度，用相应销轴把它们装配在一起（臂节一除外），装上小车和吊蓝，并把小车和吊蓝固定在臂节二上，把吊臂搁置在 1 米高左右的支架上，使小车和吊蓝离开地面，装上小车牵引机构。所有销轴都要装上开口销，并将开口销充分打开。

起重臂各种臂长配置如下（臂节一除外）：

#### 5.2.2.7 Mount one counterweight block

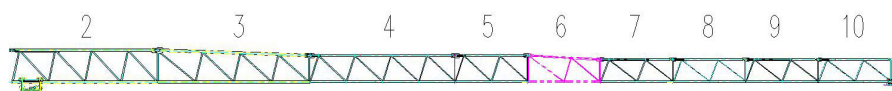
Install one block of 3.64t counterweight, near to the lifting mechanism.

#### 5.2.2.8 Installing jib

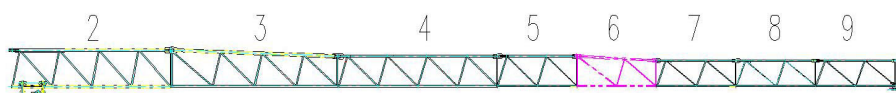
**5.2.2.8.1** Assemble the boom according to different jib length. Assemble them together with proper pins (Except jib 1), then install the trolley and its cage on jib 2, put the boom on the 1m support and lift the trolley from the ground (see Figure 4-16). All pins shall be mounted with cotter pins which shall be kept fully open.

Jib combinations with different lengths are shown in the following (except the jib 1):

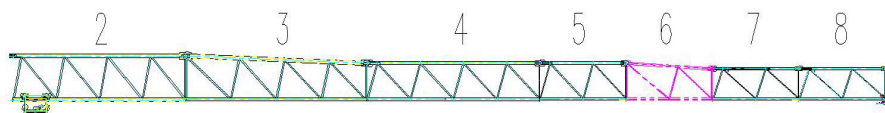
起重臂长度 70m      Jib length: 70m



起重臂长度 65m      Jib length 65m



起重臂长度 60m      Jib length 60m



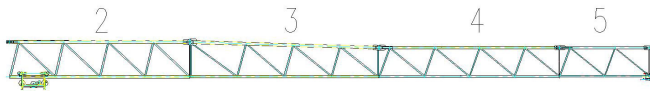
起重臂长度 55m      Jib length 55m



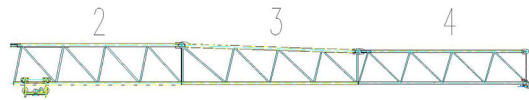
起重臂长度 50m Jib length 50m



起重臂长度 45m Jib length 45m



起重臂长度 40m Jib length 40m



**5.2.2.8.2** 检查吊臂上的电路是否完整，并穿绕上小车牵引钢丝绳

**5.2.2.8.3** 用汽车起重机将吊臂总成平稳提升，提升中必须保持吊臂处于水平位置，使吊臂能够顺利安装到平衡臂和上支座的铰点上。

**5.2.2.9** 安装平衡重，各种臂长的平衡重见 2.1.4

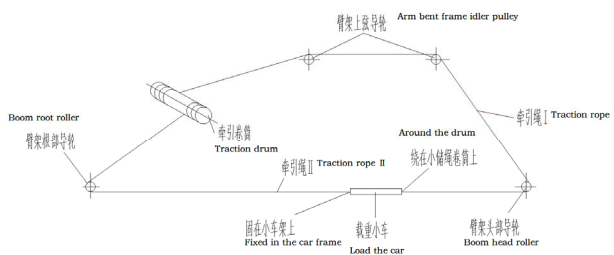
**5.2.2.10** 穿绕牵引钢丝绳

**5.2.2.8.2** Check the circuit on jib and wind the trolley traction rope.

**5.2.2.8.3** Lift up jib assembly by truck crane, keeping jib in level position, so that the jib can be successfully mounted on the hinge of jib and upper support.

**5.2.2.9** Mount counterweight and the counterweight for each jib length is shown in 2.1.4.

**5.2.2.10** Wind traction rope



**5.2.2.11** 穿绕起升钢丝绳

4 倍率：将吊钩上滑轮固定在载重小车上，如下图 A 所示。

2 倍率：将吊钩上升至小车底部，将吊钩上滑轮与吊钩用销安装，再将上滑轮与小车连接销轴拆除，将吊钩缓慢落下，二倍率时将吊钩两侧配重各拆除 1 块，共计拆

除 110kg 配重，如下图 B 所示。

- 切记：①必须先连接上滑轮与吊钩才能拆除上滑轮拆除上滑轮与小车之间的销轴，  
②使用 2 倍率时，必须从吊钩两侧各拆除 1 块配重，共计 130kg。

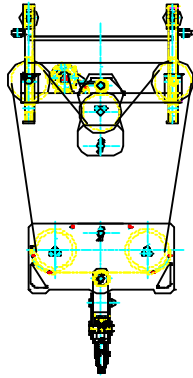
### 5.2.2.11 Wind the Lifting Steel Rope

4 times: Will be on the hook pulley fixed on the trolley,as shown in the diagram below A.

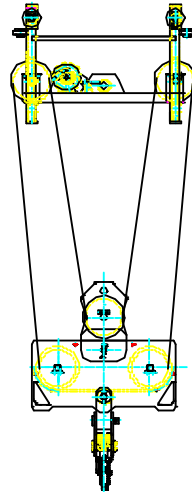
2 times:To hook up to the bottom of the car,the pulley hook and the hook pin installation,then remove the pulley connected to the car on the bin,hook,slow down,the hook when two ratio on both sides of the counterweight demolition of 130kg,are shown in figure B below.

#### Attention:

- ①Must be connected on the pulley and the hook can dismantle on pin shaft between the pulley and the car.  
②When using the two ration,1piece of weight must be demolished from hook on each side,a total of demolition of 110kg.



二倍率 二-Fall  
图 A



四倍率 四-Fall  
图 B

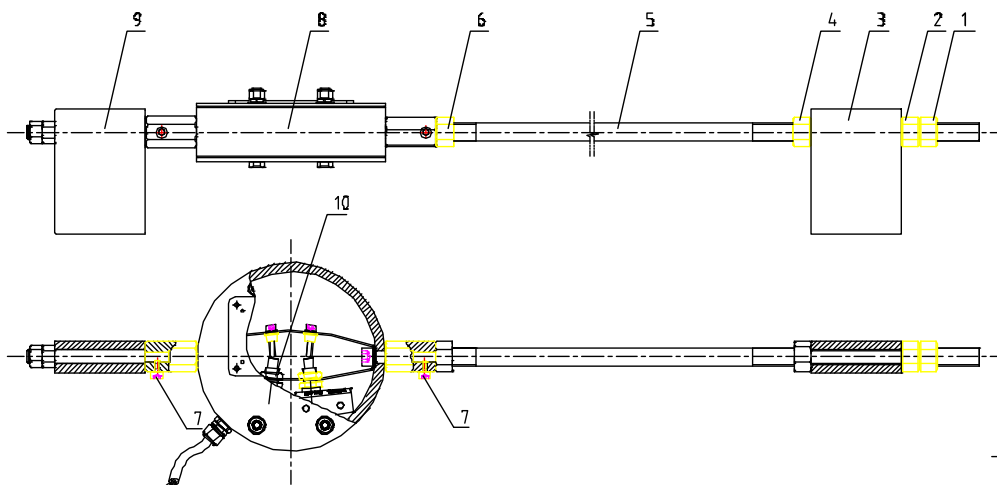
安全装置	第六章
6.1 起重力矩限制器的调整	6-3
6.2 起重量限制器的调整	6-8
6.3 起升高度限位器的调整	6-11
6.4 回转限位器的调整	6-14
6.5 幅度限位器的调整	6-15
6.6 变幅制动器	6-17
6.7 回转制动器	6-19
6.8 注意事项	6-19

Safety device	Chapter 6
6.1 Adjustment of lifting moment limiter	6-3
6.2 Adjustment of lifting weight limiter	6-8
6.3 Adjustment of lifting height stopper	6-11
6.4 Adjustment of lifting Slewing stopper	6-14
6.5 Adjustment of lifting Trolley stopper	6-15
6.6 Luffing brake	6-17
6.7 Slewing brake	6-19
6.8 Announcements	6-19



### 6.1 起重力矩限制器的调整 (结构见图 6-1)

#### 6.1 Moment limiter adjustment (see Figure 6-1)



1、顶部紧固螺帽 2、拉杆松紧调整螺帽 3、上拉铁 4、拉杆上端紧固螺帽 5、拉杆 6、拉杆下端紧固螺帽 7、侧紧固螺钉 8、环体 9、下拉铁 10、K1~K4 调整螺钉

1. Fastening nut on top 2. Elastic adjustment nut of rod 3. Pull-up iron 4. Upper fastening nut of rod 5. Rod 6. Lower fastening nut of rod 7. Side fastening screw 8. Loop body 9. Pull-down iron 10. Adjustment screw of K1 ~ K4

图 6-1 力矩限制器示意图

Fig 6-1 Diagram of Moment Limiter

塔机是按恒定的最大载荷力矩设计计算，使用中不能超过最大载荷力矩，力矩限制器的用途就是检测额定载荷的起升和向前变幅，防止超力矩到达倾翻区发生事故而设定。

The tower crane is designed based on the maximum constant load moment which can't be exceeded during application, the moment limiter is used to check the rated hoisting and forward trolley and thus to avoid over-moment happening in the tilting area which can cause accident.

工作原理:

该装置安装在塔顶靠平衡臂一侧，它由一对弹性钢板，四个微动开关及安装底座，调节螺钉，外罩等组成。当有载荷时，在载荷力矩的作用下，弹性板弯曲变形(两弹性板距离变小)，当载荷超过规定值时，其中一弹性板上的调整螺栓压下固定在另一弹性板上的开关触头，使开关动作切断其控制电路，机构停止运行，达到保护目的。

Working Principle:

This device is installed at the central position of the tower top, which is composed of a pair of elastic steel plates, three micro switches, mounting base, adjusting screw and enclosure, etc. The elastic steel plate will be bent and deformed (i.e. the distance between two plates will be shorter) under the action of load moment; when the load exceeds the rated value, the adjusting screw on one plates will be pressed and fixed on the switch contactor of the other plate, the control circuit will be disconnected by the switch and the machine will stop running to protect itself.

力矩限制器的调整:



**警告** 调整力矩限制器之前, 必须首先确认本塔机的额定力矩之后, 再查找对应的数据进行调试。

Adjustment of moment limiter:



**Warning** Confirm the rated moment of this tower crane before adjusting the moment limiter by looking for the corresponding data.

本机装有力矩限制器保护装置, 当力矩达到额定值的 90% 时, 司机室内的预报警灯亮, 当超过 100% 但小于 110% 额定值时, 起升向上断电, 小车向外变幅断电, 同时发出超载报警声。

This tower crane equips with moment limiter protection device. When the moment reaches up to 90% of rated value, the prediction alarm light will be enlightened. When the moment is over 100% but smaller than 110% of rated value, the lifting –upward will be powered off, so as to trolley-luffing –outward. At the same time, it will give overload alarm noise.

首先将拉杆松紧调整螺帽 2 用手扭紧 (一般使环体处在自然状态)。再用扳手轻微调半圈, 使开关 K4 由断开进入接通状态, 再用两只扳手紧固拉杆上端紧固螺帽 4 和顶部紧固螺帽 1。即安装完毕。四倍率, 起吊重物离地, 小车能够运行即可调整。

First, tighten the drag rod adjusting screw cap 2 manually (normally to make shoes at natural state). And then use spanner to adjust a semi circle to make switch K4 change from break-off to switch-on state. Later use two spanners tighten upper tightening screw cap 4 and cap 1. After that, all installation is completed. Lift object with 4-fall off the ground and adjust as long as trolley can run.

### 6.1.1 力矩限制器的调整

#### 6.1.1.1 调整定幅变码力矩限制器 K2

各参数见表 1-2，重复 3 次，均应满足要求。

在最大工作幅度  $R_o$  处以正常工作速度起升额定起重量  $Q_o$ ，力矩限制器不应动作，能够正常起升。载荷落地，加至  $1.1Q_o$  后以最慢速度起升，力矩限制器应动作，载荷不能起升，并输出报警信号。

#### 6.1.1 Adjustment moment limiter K2 at fixed-radius and variable-weight

6.1.1.1 The parameters are shown in Table 1-2. Repeat three times, it is qualified if it meets the requirements each time.

Lift up the rated lifting weight  $Q_o$  with normal speed at max radius, adjusting the switch K1 so that the moment limiter should not act and lift normally. Drop the load to the ground and add it to  $1.1Q_o$  and lift up slowly again, so that the moment limiter should act, and the load cannot be lifted up, releasing alarm signal.

在 0.7 倍最大额定起重量 ( $0.7Q_m$ ) 相应允许的工作幅度 ( $R_{0.7}$ ) 处，以正常工作速度起升 0.7 倍最大额定起重量 ( $0.7Q_m$ )，力矩限制器不应动作，能够正常起升。载荷落地，加至  $0.77 Q_m$  后以最慢速度起升，力矩限制器应动作，载荷不能起升，并输出报警信号。

At the allowed radius  $R_{0.7}$  of 0.7 times rated lifting weight  $0.7Q_m$ , lift up with normal speed the 0.7 times rated lifting weight  $0.7Q_m$ , so that the moment limiter should not act and lifting operation is normal. Drop the load to the ground and add it to  $0.77Q_m$  and lift up slowly again, so that the moment limiter should act, and the load cannot be lifted up, releasing alarm signal.

表 1-2 力矩限制器定幅变码调试的载荷及幅度表

Table 1-2 Parameters and radius moment limiter at fixed-radius and variable-weight

最大工作幅度	4 倍率				
Ro(m)	Qo(kg)	1.1Qo(kg)	0.7Qm(kg)	0.77Qm(kg)	R <sub>0.7</sub> (m)
70	12000	13200	8400	9240	20.92
65	12000	13200	8400	9240	24.7
60	12000	13200	8400	9240	26.9
55	12000	13200	8400	9240	29.8
50	12000	13200	8400	9240	31.7
45	12000	13200	8400	9240	34
40	12000	13200	8400	9240	33.5
35	12000	13200	8400	9240	33.6

6.1.1.2 调整定码变幅力矩限制器 K3 和定码变幅 80%力矩限制器 K1

各参数见表 1-3 重复 3 次，均应满足要求。

6.1.1.2 Adjustment of moment limiter K3 and 80% moment limit K1 at fixed-weight and variable-radius:

The parameters are shown in Table 1-3. Repeat three times, it is qualified if it meets the requirements each time.

空载测定对应最大额定起重量 (Qm) 的最大工作幅度 Rm、0.8Rm 及 1.1Rm 值，并在地面标记。在小幅度处起升最大额定起重量 (Qm) 离地 1m 左右，慢速变幅至 Rm~1.1Rm 间时，力矩限制器应动作，切断外变幅和起升回路电源，并输出报警信号。退回，重新从小幅度开始，以正常速度向外变幅，在到达 0.8Rm 时应能自动转为低速往外变幅，在到达 Rm~1.1Rm 间时，力矩限制器应动作，切断外变幅和起升回路电源，并输出报警信号。

Detect the max radius Rm, 0.8Rm and 1.1Rm with corresponding max lifting weight Qm in empty-load testing, and mark on the ground. At the small radius lift the max rated lifting weight Qm about 1m from the ground, slowly move trolley to Rm~1.1Rm point. At this time the moment limiter should be active and stop the high speed of luffing outward and release the alarm signal. Return the trolley back and start again from the small radius point,

move outward with normal speed. It moves outward to the point  $0.8R_m$  and automatically turns to low speed. At the time when the trolley is moving to the point between  $R_m \sim 1.1R_m$  the moment limiter should be active and stop luffing outward and lifting circuit power supply, releasing the alarm signal.

空载测定对应 0.5 倍最大额定起重量( $0.5Q_m$ )的最大工作幅度  $R_{0.5}$ ,  $0.8R_{0.5}$  及  $1.1R_{0.5}$  值, 并在地面标记。在小幅度处起升 0.5 倍最大额定起重量 ( $0.5Q_m$ ) 离地 1m 左右, 慢速变幅至  $R_{0.5} \sim 1.1R_{0.5}$  间时, 力矩限制器应动作, 切断外变幅和起升回路电源, 并输出报警信号。退回, 重新从小幅度开始, 以正常速度向外变幅, 在到达  $0.8R_{0.5}$  时应能自动转为低速往外变幅, 在到达  $R_{0.5} \sim 1.1R_{0.5}$  间时, 力矩限制器应动作, 切断外变幅和起升回路电源, 并输出报警信号。

Detect the radius  $R_{0.5}$ ,  $0.8R_{0.5}$  and  $1.1R_{0.5}$  with the corresponding max lifting weight  $0.5Q_m$  in empty-load testing, and mark on the ground. At the small radius lift the 0.5 times max rated lifting weight  $Q_m$  about 1m from the ground, slowly move trolley to  $R_{0.5} \sim 1.1R_{0.5}$  point. At this time the moment limiter should be active and stop the high speed of luffing outward and release the alarm signal. Return the trolley back and start again from the small radius point, move outward with normal speed. It moves outward to the point  $0.8 R_{0.5}$  and automatically turns to low speed. At the time when the trolley is moving to the point between  $R_{0.5} \sim 1.1 R_{0.5}$  the moment limiter should be active and stop luffing outward and lifting circuit power supply, releasing the alarm signal.

表 1-3 力矩限制器定码变幅调试的载荷及幅度表

Table 1-3 Parameters and radius moment limiter at fixed-weight and variable-radius

臂长	4 倍率				2 倍率			
	R(m)	$Q_m$ (kg)	$0.8R_m$ (m)	$R_m$ (m)	$1.1R_m$ (m)	$0.5Q_m$ (kg)	$0.8R_{0.5}$ (m)	$R_{0.5}$ (m)
70	12000	12.1	15.1	16.61	6000	22.88	28.6	31.46
65	12000	15.6	19.5	21.45	6000	29.25	36.9	40.59
60	12000	17.04	21.3	23.43	6000	32.24	40.3	44.33
55	12000	18.8	23.5	25.85	6000	35.6	44.5	48.95
50	12000	20.1	25.1	27.61	6000	32	40	44
45	12000	21.44	26.8	29.48	6000	32	40	44

40	12000	21.2	26.5	29.15	6000	24	30	33
35	12000	21.2	26.5	29.15	6000	24	30	33

6.2 重量限制器(结构调整方法见图 4-29, 此塔机只使用其四个微动开关中的三个)。

用途:

塔机结构及起升卷扬钢丝绳是按最大载荷设计计算的, 工作载荷不能超过最大载荷。起重量限制器就是用于限制超载现象的发生而设定的一种安全装置。

6.2 Lifting weight limiter (Structure adjustment method is shown in Fig 6-2, and this tower crane only uses three of four inch switches)

Use:

The tower crane structure and lifting rope is calculated depending on the designed max load. The working load shall not be over the max load. The lifting weight limiter is a safety device used to limit over-loading.

工作原理:

起升钢丝绳经过测力环滑轮时, 由于载荷的作用, 钢丝绳产生张力, 张力传到与滑轮连接的测力环上, 该测力环随着负载的变化而发生变形, 使固定于环内的金属板条亦发生变形(原理同力矩限制器), 其上装有微动开关及可调螺栓, 根据载荷的要求, 经适当调整后, 压开微动开关起到控制电路的作用。

Working principles:

When getting through the dynamometer ring pulley, because of load, the rope has tension sent on the dynamometer ring connected with pulley. The dynamometer ring will deform with the change of load, and it is same to metal strip in ring (the principle is same to moment limiter). The inching-switch and adjustable bolt after being adjusted, according to load requirements, can control the electric circuit when in switch-on.

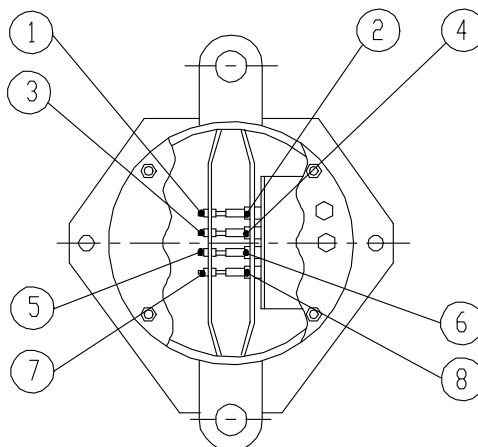


图 6-2 起重量限制图

Fig. 6-2 Load limiter

起重量限制器的调整:



**警告**

调整起重量限制器之前, 必须首先确认本塔机的额定吊重量后, 再查找对应的数据进行调试。

Adjustment of lifting weight limiter

**Warning!** Before adjustment of the load limiter, you should firstly confirm the tower crane's rated load, and then choose the corresponding data for debugging.

①调整高速限制器 K4

先以低速(1、2、3、4 档)起吊载荷 V, 然后再以高速 (5 档) 起升。调整螺栓(4)直至其头部接触到微动开关(K4)。

降下载荷, 增重 10%, 以低速起吊新增重载荷 W, 然后试换速高速起升, 此时不应有高速 5 档。如果得到高速, 应重新调整。

重复 3 次, 均应满足以上要求。

①Adjusting high-speed limiter K4

Lift up the load V at low speed(1 gear,2gear,3gear,4gear) and then at high speed(5gear). Adjust bolt 4 until its top contacts the inching-switch K4.

Lower the load and add its 10% on it making it become the new load W. Lift it up again at low speed and then try to change to high speed, at this case there shall not high-speed 5gear. If it has high speed, readjust it.

Repeat three times, it is qualified if it meets the requirements each time.

②调整中速限制器 K2

先以低速(1、2、3 档)起吊载荷 X, 然后再以高速 (4) 起升。调整螺栓(2)至其头部接触到微动开关(K2)

降下载荷, 增重 10%, 以低速起吊新增重载荷 Y, 然后试换速高速起升, 此时不应有高速 4。如果得到高速, 应重新调整。

重复 3 次, 均应满足以上要求。

### ② Adjusting medium-speed limiter K2

Lift up the load X at low speed(1 gear,2gear,3gear) and then at high speed 4gear. Adjust bolt 2 until its top contacts the inching-switch K2.

Lower the load and add its 10% on it making it become the new load Y. Lift it up again at low speed and then try to change to high speed, at this case there shall not high-speed 4gear. If it has high speed, readjust it.

Repeat three times, it is qualified if it meets the requirements each time.

### ③ 调整最大起重量限制器 K1:

以低速(1、2、3 档)起吊载荷 K, 调整螺栓(1)直至其头部接触到微动开关 K1 为止。

降下载荷, 增重 10%, 试以低速起吊该载荷 Z, 如果载荷被吊起, 则应重新调整。

重复 3 次, 均应满足以上要求。

### ③ Adjusting max weight limiter K1

Lift up the load K at low speed(1 gear,2gear,3gear). Adjust bolt 1 until its top contacts the inching-switch K1.

Lower the load and add its 10% on it making it become the new load Z. If it is lifted up, readjust it.

Repeat three times, it is qualified if it meets the requirements each time.

对于不同的载荷值 V、W、X、Y, K, Z 参见表 1-4。

The values of V、W、X、Y, K, Z are shown in the below Table 1-4

表 1-4 起重量限制器调试参数表

**Table 1-4 Debugging parameters of load limiter**

倍率 Fall	限高速起重量限制器 (K4) High-speed-limit load limiter		限中速重量限制器 (K2) Medium-speed-limit load limiter		限超载起重量限制器 (K1) Overload-limit load limiter	
	V(kg)	W(kg)	X(kg)	Y(kg)	K(kg)	Z(kg)
2 倍率 2-fall	2100	2205	4200	4410	6000	6600
4 倍率 4-fall	4200	4410	8400	8820	12000	13200

### 6.3 起升限位器

用途:起升限位器的用途在于防止可能出现的操作失误。

当吊钩滑轮组距小车 2m 时，即停止上升运动。

在下降时，防止钢丝绳完全松脱及以相反方向缠绕在卷筒上。

工作原理:固定于卷筒支架上的限位开关减速装置，它可由卷筒轴直接驱动或者通过小齿轮啮合于齿圈上来驱动，该减速装置又驱动若干个凸块旋转，这些凸块控制微动开关从而切断相应的运动。

#### 6.3Hoist stopper

Application:

The hoist stopper can be used to avoid the possible operational errors.

When the hook-pulley assembly is 2m from the trolley, the lifting will stop.

During the falling process, the steel wire rope shall be prevented from loosing and winding around the roller in an opposite direction.

Working Principle:

The decelerator of limit switches fixed on the roller support can be driven directly by the roller shaft or by engaging the pinion on gear ring. This decelerator can drive several lugs rotate, and these lugs can be used to control the micro switch to stop corresponding motions.



**注意**

在每一次塔机立塔投入使用前，必须拔下位于限位器底部的塞子，排去其中可能存在的冷凝水，塔机拆塔转场前必须再塞上塞子，提高运输和储存过程中限位器的防护等级，防止限位器进水。



**Caution**

Every time before the tower crane is put into operation, remove the plug from the stopper bottom first to discharge the possible condensate water, and

**reassemble it before the tower crane is removed for transfer, to improve the protection grade of the stopper during transportation and storage process, so as to prevent water entering into the stopper.**

起升限位器的调整:

在塔身高度到达预定高度后,调整必须在空载下进行,控制起升或下降,进行调整,并且用手动操纵触点 1WK 或 4WK,以便确定切断控制运动的是哪一个。(注:改变塔机高度或倍率时,均应调整上升限位器、上减速限位器及下降限位器)

Hoist stopper adjustment:

Adjust the tower body when it reaches the preset height under un-loading conditions, control its lifting or lowering, operate the contactor 1WK or 4WK manually to determine which one stops the control operation. (Note: adjust the hoist stopper, upper decelerating stopper and lowering stopper when change the tower crane height or multiplying power)

调整起升上限位 SHUL

双绳或四绳起升吊钩,直至小车与吊钩滑轮组仅相距 4m (2 倍率)或 2m (四倍率)距离,用相应的调整螺丝旋动凸块(4T),检查起升控制,直至其压下相应的触点 4WK,起升停止。(见图 4-25)。

重复 3 次,均应满足以上要求。

Adjust the upper hoist limiter SHUL:

Lift the hook with two ropes or four ropes until the distance between the trolley and hook-pulley assembly is 4m (two ropes) or 2m (four ropes), rotate the lugs (4T) with proper adjusting screw, check the lifting control, and the lifting will stop until the corresponding contactor 4WK is pressed downward. (See Figure 4-25)

Repeat this for 3 times and comply with the above requirements.

调整起升下限位 SHDL

双绳或四绳起升吊钩,直至吊钩与地面仅相距 1m 距离或卷筒上还剩 3 圈钢丝绳时,用相应的调整螺丝旋动凸块(1T),检查起升控制,直至其压下相应的触点 1WK,起升停止。(见图 4-26)。

重复 3 次,均应满足以上要求。

Adjust the lower hoist limiter SHDL:

Lift the hook with two ropes or four ropes until the distance between the hook and

ground is 1m or 3 cycles of steel wire rope are left on the roller, rotate the lugs (1T) with proper adjusting screw, check the lifting control, and the lifting will stop until the corresponding contactor 1WK is pressed downward. (See Figure 4-25)

Repeat this for 3 times and comply with the above requirements.

调整起升上减速限位 SHUC

起升吊钩直至小车与吊钩滑轮组相距 10m (2 倍率) 或 5m (四倍率) 距离, 用相应的调整螺丝旋动凸块(3T), 检查起升控制, 直至其压下相应的触点 3WK, 起升上升减速运行。(见图 4-27)。

重复 3 次, 均应满足以上要求。

Adjust the upper hoist decelerating limiter SHUC:

Lift the hook until the distance between the trolley and hook-pulley assembly is 10m (two ropes) or 5m (four ropes), rotate the lugs (3T) with proper adjusting screw, check the lifting control, and the hoist decelerating limiter will run until the corresponding contactor 3WK is pressed downward.(see Figure 4-25)

Repeat this for 3 times and comply with the above requirements.

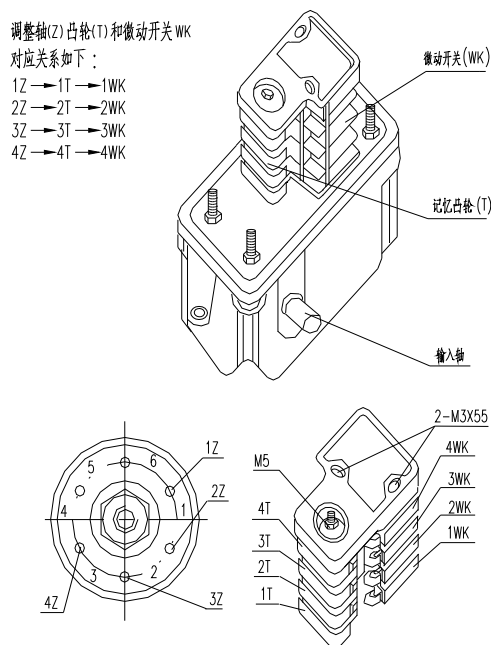


图 4-25 起升限位器图

Figure 4-25 Diagram of Hoist Stopper

## 6.4 回转限位器

用途：该装置用于防止电缆缠绕及损坏。回转限位器允许最大回转圈数为 3 圈。

工作原理：回转限位器带有由小齿轮驱动的减速装置，小齿轮直接与回转齿圈啮合，当塔机回转时，限位器减速装置带动凸块 4T、1T 旋转，凸块又控制微动开关 4WK、1WK，这样通过调整即可在适当位置使回转停止运行。(见图 4-26)。

### 6.4 Slewing stopper

#### Application:

This device can be used to avoid cable winding and damage. The maximum slewing cycles for the slewing stopper is 3.

#### Working Principle:

The decelerator, which is driven by the pinion, is installed on the slewing stopper, and the pinion is directly engaged with the slewing gear ring. The stopper decelerator will drive the lugs 4T and 1T to rotate while the tower crane is slewing, as the lugs can control the micro switches 4WK and 1WK in return, the slewing can be stopped at appropriate positions through proper adjustment. (see Figure 4-26)

#### 回转限位器的调整：

在空载下进行调整，控制做回转或右回转，调整触点(4Z)，确定切断回转运动的是哪一个。

调整右回转限位器 SSR：旋转臂架使电缆不致缠绕，向右回转一圈半，然后调整凸块(4T)检查其动作，直至其压下相应的触点(4WK)。

重复 3 次，均应满足以上要求。

#### Slewing stopper adjustment:

Conduct the adjustment under un-loading conditions, control the left slewing or right slewing, and adjust the contactors (4Z) to determine which one can stop the slewing.

Adjust the right slewing stopper SSR: rotate the boom frame to separate the cables, slew to the right by one cycle and a half, adjust the lug (4T) and check its motions until the corresponding contactor (4KW) is pressed downward.

Repeat this for 3 times and comply with the above requirements.

然后调整左回转限位器 SSL：向相反的方向转 3 圈，调整凸块(1T)直至其压下触点

(1WK)。

重复 3 次，均应满足以上要求。

After that, please adjust the left slewing stopper SSL: turn to the opposite direction for 3 cycles, and adjust the lug (1T) until the corresponding contactor (1KW) is pressed downward.

Repeat this for 3 times and comply with the above requirements.

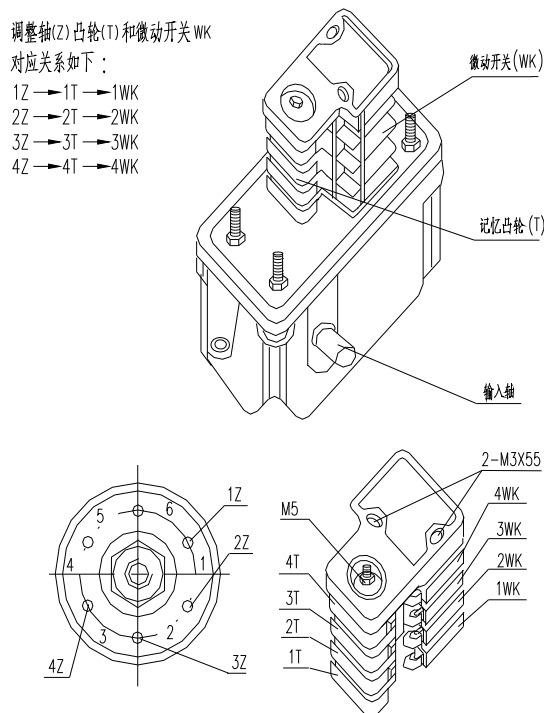


图 4-26 回转限位器图

Figure 4-26 Diagram of Slewing Stopper

### 6.5 变幅限位器

用途：变幅限位器用途在于防止可能出现的操作失误，使小车距离臂端或臂架根部有一定的安全距离运行。

工作原理：变幅限位器带有由小齿轮驱动的减速装置，通过一个小齿轮与固定于卷筒上的齿圈啮合，减速装置带动凸块旋转，凸块控制微动开关，这样通过调整即可在适当位置使变幅减速或停止运行。(见图 4-27)。

### 6.5 Trolley stopper

Application:

The trolley stopper can be used to avoid the possible operational errors and make the trolley operate with a safe distance from the boom end or boom frame root.

### Working Principle:

The decelerator, which is driven by the pinion, is installed on the trolley stopper, and the pinion is engaged with the gear ring fixed on the roller. As the decelerator can drive the lugs to rotate and the lugs can control the micro switches in return, the trolley speed can be reduced or the trolley can be stopped at appropriate positions through proper adjustment. (See Figure 4-27)

### 变幅限位器的调整:

调整向外变幅减速限位器 SVFC 开至距臂尖缓冲器 1.5m 处, 转动凸块(3T)直至其压下相应的触点。

重复 3 次, 均应满足以上要求。

### Trolley stopper adjustment:

Adjust the outward trolley decelerating stopper SVFC: drive the trolley to a position 1.5m from the boom end bumper, rotate the lug (3T) until the corresponding contactor is pressed downward.

Repeat this for 3 times and comply with the above requirements.

调整向外变幅限位器 SVFL 开至距臂尖缓冲器 20cm 处, 转动凸块(6)直至其压下相应的触点。

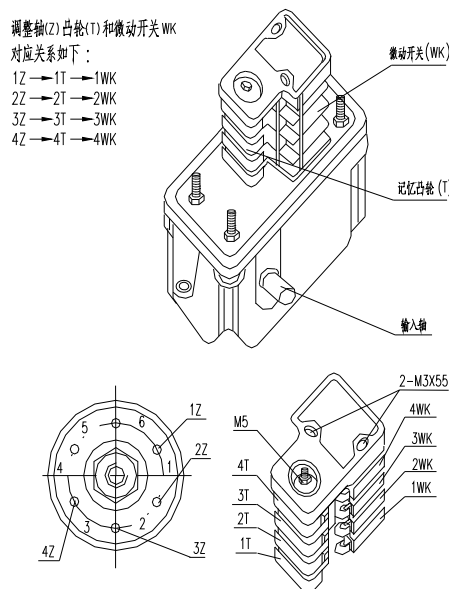
重复 3 次, 均应满足以上要求。

Adjust the outward trolley stopper SVFL: drive the trolley to a position 20cm from the boom end bumper, rotate the lug (6) until the corresponding contactor is pressed downward.

Repeat this for 3 times and comply with the above requirements.

调整向内变幅减速限位器 SVBC 和向内变幅限位器 SVBL, 如上所述调整, 将小车开至臂根, 转动凸块(2T)直至其压下相应的触点(2WK), 接着调整限位凸块(1T), 使其压下触点(1WK)。重复 3 次, 均应满足以上要求。

Adjust the inward trolley decelerating stopper SVBC and inward trolley stopper SVBL: drive the trolley to the boom root based on the above requirements, rotate the lug (2T) until the corresponding contactor (2WK) is pressed downward, then adjust the limit lug (1T) to



press the contactor (1WK). Repeat this for 3 times and comply with the above requirements.

图 4-27 变幅限位器图

Figure 4-27 Diagram of trolley stopper

### 6.6 变幅制动器 (见图 6-2)

### 6.6 Luffing brake (see Fig 6-2)

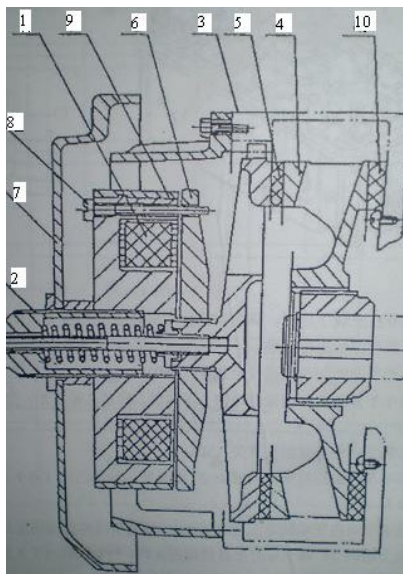


图 6-2 变幅小车制动器示意图

Fig 6-2 Trolley Luffing brake

(1) 总述

该制动器为常闭式制动器，使用直流 24V 电源供电，一旦电源断电，制动器便动作。

(2) 制动过程

制动线圈①失电，制动弹簧②推动衔铁⑥，衔铁又推制动盘③，使摩擦盘④紧贴在主动摩擦片⑤与被动摩擦片⑩之间，阻止电机轴的转动，完成制动。

(3) 释放

制动线圈得电，吸引衔铁，并压缩弹簧，电机轴放松，制动器释放。拧紧释放螺母，制动器手动释放。注意重新起动机时，应恢复原状。

(4) 间隙调整

移去防护⑦，取下定位螺钉⑧，通过外沿凹槽反时针拨动衔铁，直至不能转动为止，然后顺时针拨动衔铁，当碰到其上第三个孔时，穿进定位螺钉拧紧，此时间隙为 0.6—0.8mm。

(1) Overview

The brake is constant closed type, using DC 24V. So once the power is off, the brake acts.

(2) Braking process

If the braking ring ① is powered off, the brake spring ② pushes the armature ⑥ to drive brake disk ③, consequently the friction disk ④ will attach between initiative friction disk ⑤ and passive disk v, and then the motor shaft will be stopped. Thus the brake operation is finished.

(3) Releasing

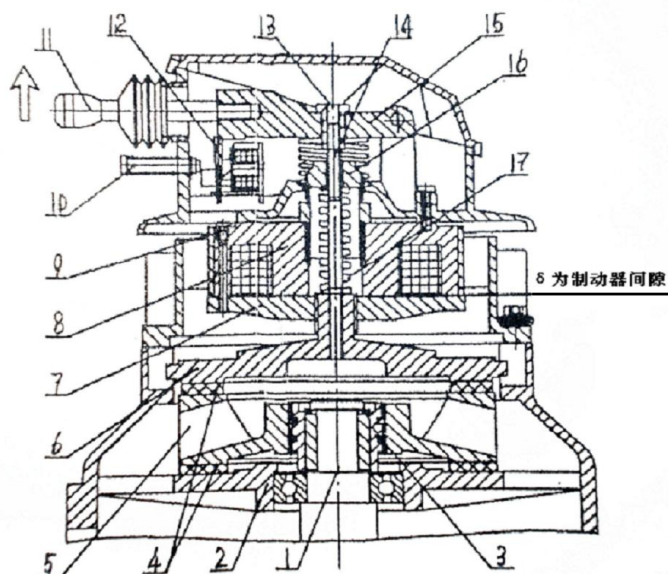
If the braking ring is powered on, attracting armature and pressing spring, the motor shaft will be release, as well as brake. Tightening releasing nut, the brake will be released manually. Pay attention that when restarting, the brake shall be its original state.

(4) Clearance adjustment

Remove cover ⑦and positioning screw ⑧, move the armature anticlockwise along with outer border of groove until it cannot be moved. And then move the armature clockwise till it touches the third hole, inserting positioning screw. In this case the clearance is 0.6~0.8mm.

## 6.7 回转制动器 (见图 6-3)

### 6.7 Slewing brake (Fig 6-3)



- 1.转子 2.后端盖 3.花键套 4.摩擦片 5.叶轮 6.制动盘 7.衔铁 8.电磁铁 9.定位螺钉  
10.推杆 (风标) 11.手柄 12.衔铁 (风标) 13 调节螺母 (风标) 14.制动盘螺杆 15.杠杆  
16.调整套 17.主弹簧

图 6-3 回转制动器示意图

1. Rotator 2 Rear cover 3 Splined sleeve 4. Friction disc 5. Impeller 6 Brake disc 7. Armature 8  
Electric magnet 9 Positioning screw 10 Push rod (wind mark) 11 hand shank 12 Armature (wind mark) 13.  
Adjusting nut (wind mark) 14 brake disc screw 15 lever 16 adjusting sleeve 17 main spring

Fig 6-3 Slewing brake

## 6.8 注意事项

- 6.8.1** 安全装置不准或失灵, 未经调整或修理, 确认灵敏可靠, 起重机不能使用, 否则由此造成的一切后果, 用户自行负责。
- 6.8.2** 安全装置是在操作人员失误情况下的自动保护装置, 操作人员不能依赖安全装置, 无安全意识而经常性重载作业或违章作业。
- 6.8.3** 经过培训, 并由制造厂认可的人员才可调整塔机的安全装置。特别重要的是力矩限制器和起重量限制器, 在没有合格的吊重砝码和测量工具时, 不允许调整。
- 6.8.4** 安全装置在使用中的检验和调整

对使用中的安全装置有下列情况之一者, 须进行检验和重调试验:

- a. 正常使用的起重机, 每周应对安全装置进行检验, 发现不准确或失灵时;

- b. 使用间隔一年后;
- c. 对安全装置工作性能有疑问时;
- d. 转移工地时;
- e. 长期停止使用重新使用时。

**6.8 Notes:**

**6.8.1** Once the safety devices are not precise or out of work, the crane cannot be used before the devices have been repaired or adjusted.

**6.8.2** The safety devices are a kind of self protection in case the operator makes mistakes; anyway the operator cannot rely on the safety devices for no safety care or break the operation regulations.

**6.8.3** Only after training or the technician from the manufacturer can adjust the crane's safety devices, especially for moment limiter and lifting weight limiter, an adjustment cannot be done without a regular poise or any weight measurement tools.

**6.8.4** Check and adjustment of the safety devices during operation.

For any of the following situation, a test and check should be done:

- a. For normally used tower crane, check the safety device weekly, and if there is any abnormal situation;
- b. After one year of operation;
- c. Any doubt to the safety device;
- d. Change of the working site;
- e. Longtime of quit before start using.

起重机的使用与操作	第七章
7.1 一般说明	7-3
7.2 起重机的操作	7-3
Tower crane operation	Chapter 7
7.1 Instruction	7-3
7.2 Crane operation	7-5

## 7.1 一般说明

7.1.1 起重机必须在符合设计图纸规定的基础上工作。

7.1.2 起重机的操作人员必须经过训练，了解机械的构造和使用，必须熟知机械的保养和安全操作规程，非安装、维护人员未经许可不得攀登起重机。

7.1.3 起重机正常工作气温为  $-20^{\circ}\text{C}\sim 40^{\circ}\text{C}$ ，风速低于 20m/s。

7.1.4 起重机每转移一次工地重新安装后，必须进行空载、静载、动载试验及对各种安全装置进行调整（见有关调整方法）后方能进行吊装作业，其静载试验吊重为额定载荷的 125%，动载试验吊重为额定载荷的 110%。

### 7.1 General description

7.1.1 Crane should work on the fixed foundation conforming to the design.

7.1.2 The operating personnel of crane must be trained about the structure and operation of the crane, and taught to proficient maintenance and safe operation regulations. Non-operating and maintenance personnel should not climb the crane without permission.

7.1.3 The normal temperature range of crane working is  $-20^{\circ}\text{C}\sim 40^{\circ}\text{C}$ , and wind velocity is below grade 6.

7.1.4 Every time when crane is relocated to another new construction site, it is suggested to conduct tests about no load, static load and dynamic load and adjust all kinds of apparatus before the mounting operation starts (refer to related adjustment methods). The mounting weight in static load test is 125% of rated load, and 110% of that in dynamic load test.

7.1.5 在夜间工作时，除起重机本身备有照明外，施工现场必须备有充分的照明设备。

7.1.6 司机室内禁止存放润滑油、油棉纱及其它易燃易爆品，冬季用电炉取暖时更要注意防火。

7.1.7 本机在三相五线制电网中使用，零线不能接塔身。

7.1.8 安装前应首先遥测各部分对地绝缘电阻，电动机的绝缘电阻不得低于  $0.5\text{M}\Omega$ ，导线间，导线对地绝缘电阻不能低于  $1\text{M}\Omega$ 。

7.1.9 起重机应定机定人，专机专人负责制，非机组人员不得进入司机室和擅自操作，在处理电气事故时，必须有专职维修人员两人以上。

7.1.5 The substantial lighting equipments are required at construction site besides the lighting facilities of crane itself when it is working at night.

**7.1.6** It is forbidden to place lubricant, oil cotton yarn and other flammable and detonable articles in driver's cab. When it is needed to get warmth by electric stove in winter, more attention shall be paid to fire prevention.

7.1.7 Tower crane adopts with three-phase-five-wire electric network, without zero line connecting to tower body.

7.1.8 Before the installment, measure the insulated resistance of each part of the crane against the earth, the insulated resistance of electromotor shall not be less than  $0.5M\Omega$ ; between the leading wires, the insulated resistance of the leading wires against the earth shall not be less than  $1M\Omega$ .

**7.1.9** Certain person or operator should be working on a certain tower crane. Any irrelevant person is forbidden to enter the cab or for operation. Only special technicians can deal for the problems of the electric system.

## 7.2 起重机的操作

### 7.2.1 操作前的准备

7.2.1.1 起重机开始工作之前，司机必须检查各部件、零件是否完好，特别是钢丝绳和连接螺栓、连接销，检查各安全装置和制动器是否有效。

7.2.1.2 发现的任何故障都应记录在册，可能影响安全的故障排除之前，司机不得进行操作。

7.2.1.3 检查各工作装置和操纵机构是否处于正常位置。

7.2.1.4 检查电气联接，接地是否正确,电压正常。

7.2.1.5 各机构操纵手柄处于“0”位。

7.2.1.6 确保一切正常，接通电源。

## 7.2 Operation of crane

### 7.2.1 Preparation work prior to operation

7.2.1.1 Before crane starts working, the driver is required to check whether or not all components and parts are in good condition, especially the steel wire ropes, joint screw bolts and connecting pins, and safety devices and arresters are effective.

7.2.1.2 All failures detected are required to be recorded. Driver is not allowed to operate it until failures which properly affect safety are eliminated.

7.2.1.3 To check whether or not all working devices and operating mechanism are in the normal position.

7.2.1.4 To check whether or not electrical connection, grounding connection and power voltage are in normal condition.

7.2.1.5 Operating hand of various mechanism should be place in “0” position.

7.2.1.6 To ensure everything is under control, and connect power.

## 7.2.2 操作注意事项

7.2.2.1 司机必须在得到指挥信号后，方可进行操作，操作前必须鸣笛，操作时要精神集中。

7.2.2.2 司机必须严格按起重机性能表中规定的幅度和起重量进行工作，不许超载使用。

7.2.2.3 起重机不得斜拉或斜吊物品，并禁止用于打桩等类似作业；起重臂上的吊蓝仅供维修时用，工作中严禁放在小车上，而应固定在臂架根部。

7.2.2.4 工作中塔机上严禁有人，并不得在工作中进行调整或维修机械等作业。

7.2.2.5 工作时严禁闲人走近臂架活动范围内。

7.2.2.6 液压系统安全阀的数值，电器系统保护装置的调整值及其它机构、结构部件的调整值（如制动器、限位开关等）均不允许随意改动。

7.2.2.7 有两台以上起重机工作时，要根据工程特点，注意相互之间的位置，并采用不同标高的方法，以避免起重机的起重臂、平衡臂相互碰撞以及与建筑物碰撞。

7.2.2.8 起重机作业完毕后，回转机构松闸，吊钩升起，小车停在臂架端部，即最大幅度处。

## 7.2.2 Operation notice:

7.2.2.1. Driver is allowed to start operation after receiving commanding signal, whistles before starting operation and has full concentration during operation.

7.2.2.2. Driver is required to use crane strictly according to its scopes and lifting capacity. Over loading is prohibited.

7.2.2.3. Crane is not allowed to slanting drag or lifting articles, and prohibited from works, such as piling stakes. The nacelle of crane is only allowed for use in case of maintenance,

and prohibited from being placed on small cart during working but should be fixed on foundation of arm frame.

7.2.2.4. People are forbidden to stand on the stairs of Tower, and to conduct adjustment or repair work of machines as such.

5. Propel are forbidden to get close to working range of arm frame during operation.

7.2.2.6. The value of safety valves in hydraulic system, regulating value of protection devices of electrical system and other mechanism and structural components (such as arresters and limited switches etc.) are not liable to be changed without permission.

7.2.2.7. When more than two cranes in working, it is necessary to pay attention to the inter-location of them according to the engineering situations and prevent the shear leg and balancing arms of the cranes from collision with each other or with the buildings by adopting different methods of elevation.

7.2.2.8. After the crane works, the slewing mechanism shall be switched off and the hook shall be hoisted and the cart shall be stopped at the end of the arm support, ie at the max radius.

起重机的维护与保养 故障与排除	第八章
8.1 机械设备维护与保养	8-3
8.2 液压顶升系统的维护与保养	8-3
8.3 金属结构的维护与保养	8-3
8.4 电气系统的维护与保养	8-4
8.5 钢丝绳	8-4
8.6 回转支承	8-13
8.7 起重机维修时间的规定	8-14
8.8 起重机常见故障与排除	8-16

Tower crane repair and maintenance	Chapter 8
8.1 Mechanical equipment maintenance	8-3
8.2 Hydraulic control system maintenance	8-3
8.3 Metal structure maintenance	8-4
8.4 Electric system maintenance	8-4
8.5 Steel rope	8-4
8.6 Slewing bearing	8-13
8.7 Tower crane maintenance time	8-12
8.8 Common breakdowns and trouble-shooting	8-14



起重机应当经常进行检查、维护和保养，传动部分应有足够的润滑油，对易损件必须经常检查、维修或更换，对机械的螺栓，特别是经常振动的零部件，如塔身连接螺栓应进行检查是否松动，如有松动必须及时拧紧或更换。



特别值得注意的是根据 JG/T5057.40-1995 标准规定，高强度螺栓、螺母使用后拆下再次使用，一般不得超过两次。且拆下的螺栓、螺母必须无任何损伤、变形、滑牙、缺牙、锈蚀、螺纹粗糙度变化较大等现象，否则应禁止再用于受力结构的连接。

Crane should be examined and maintained periodically. The drive part should have enough lubrication oil. Wearing parts should be examined, repaired or changed frequently. Examine whether the bolt of machine, especially the frequently vibrated part, is loose or not, such as tower joint bolt. If the bolt is loose, screw down or change it timely, all the change should be recorded on time.



**Use the high strength bolt and the nut, then, dismount them, and later, use them again. We should not do as the above said more than twice times according to regulations of JC/T5057.40-1995 standard. Furthermore the dismounting bolt and nut should not have any phenomenon such as damage, deforming, tooth sliding, tooth missing, rust, screw thread with high roughness, or forbid to use it to joint the stress structure.**

## 8.1 机械设备维护与保养

8.1.1 各机械的制动器应经常进行检查和调整制动瓦和制动轮的间隙，保证灵活可靠，其间隙保证在 0.5~1mm 之间。在摩擦面上，不应有污物存在，遇有污物必须用汽油或稀料冲洗。

8.1.2 减速箱、变速箱、外啮合齿轮等各部分的润滑以及液压油均按润滑表中的要求进行。

8.1.3 要注意检查各部钢丝绳有无断丝和松股现象，如超过有关规定必须换新。钢丝绳的维护保养应严格按 GB5144-2006 规定的执行。

8.1.4 凡开式齿轮传动必须有防护罩。

8.1.5 经常检查各部的连接情况，如有松动应予以拧紧。塔身连接螺栓应在塔身受压时

检查松紧度（可采用旋转臂架的方法去造成受压状态），所有连接销轴都必须装有开口销，并需张开。

8.1.6 经常检查各机构运转是否正常，有无噪音，如发现故障必须及时排除。

8.1.7 安装、拆卸和调整回转机构时，要注意保证回转机构减速器的中心线与齿轮中心线平行，其啮合面不小于 70%，啮合间隙要合适。

## 8.1 Maintenance of Mechanical Equipment

8.1.1 Examine breaks of various machines frequently, and adjust the clearance between brake scotch and brake wheel in order to keep them flexible and reliable. Ensure the clearance is within 0.5~1mm. There should not have any dirt upon surface of friction. If there is any dirt, use the petrol or the thinner to wash it.

8.1.2 Lubricate the positive speed gearbox, adjustable speed transmission and external gear pump and other parts and hydraulic oil in accordance with the requirements of lubrication table.

8.1.3 Pay attention to examine whether each cable wire has the phenomenon of filament break and loose strand. If it is not conform to related regulations, change it at once. The maintenance of cable wire should be carried out strictly in accordance with the regulations of GB5144-2006.

8.1.4 Examine the joint situation of each part frequently. If it is loose, screw down it. Examine the degree of tightness of tower joint bolt when the tower body is pressed (use rotating arm to make the tower body on the compression). All joint pin shafts should be equipped with cotter pin, and the cotter pin should be open.

8.1.5 Examine whether the operation of various mechanism is normal or not and whether it has noise. If finding breakdown, clear it timely.

8.1.6 When mounting, dismounting and adjusting the slewing mechanism, pay attention to ensure the central line of speed reducer of slewing mechanism is paralleled with the central line of gear. Field of conjugate action should not be smaller than 70%, and backlash should be suitable.

## 8.2 液压顶升系统的维护与保养

8.2.1 使用液压油时要严格按表中的规定进行回油和换油，并清洗油箱内部。

8.2.2 溢流阀的压力调整后，不得随意更改，每次进行爬升之前，应用油表检查压力是否正常。

- 8.2.3 应经常检查各部接头是否紧固严密，不准有漏油现象。
- 8.2.4 滤油器要经常检查有无堵塞，检查安全阀在使用后调整值是否变动。
- 8.2.5 油泵、油缸和控制阀，如发现渗漏应及时检修。
- 8.2.6 总装和大修后初次起动油泵时，应先检查出口和入口是否接反，转动方向是否正确，吸油管路是否漏气，然后用手试转，最后在规定范围内起动和试运转。
- 8.2.7 在冬季起动时，要开开停停往复数次，待油温上升和控制阀动作灵活后再正确使用。

## 8.2 The maintenance of hydraulic jacking system

- 8.2.1 When using hydraulic oil, return and change the oil according to the speculations of the table, and clear the inner part of oil tank.
- 8.2.2 After adjusting the pressure of overflow valve, do not change it at random. Use the oil gauge to examine whether the pressure is normal before climbing.
- 8.2.3 Examine whether the joint of each part is tight frequently. Do not allow any oil leakage.
- 8.2.4 Examine whether the oil filter is blocked or not frequently. Examine whether the adjusted value is changed or not after using the blow through valve.
- 8.2.5 If finding the oil pump, oil cylinder and control valve leak, examine and repair it timely.
- 8.2.6 After final assembly and heavy repair, start the oil pump for the first time, examine whether the exit and the entrance is jointed oppositely, whether the direction of rotation is correct, and whether the inlet line leaks; and then try to turn it by hand; finally start and make trail operation within the stipulated area.
- 8.2.7 When start in winter, start and stop it for several times. Do not use it until the oil temperature raises and control valve becomes flexible.

## 8.3 金属结构的维护与保养

- 8.3.1 在运输中应尽量设法防止构件变形及碰撞损坏。
- 8.3.2 在使用期间，必须定期检修和保养，以防锈蚀。
- 8.3.3 经常检查结构连接螺栓、焊缝以及构件是否损坏、变形和松动等情况。
- 8.3.4 每隔 1~2 年喷刷油漆一遍。

## 8.4 电气系统的维护与保养

- 8.4.1 经常检查所有电缆、电线有无损伤，要及时的包扎和更换已损伤的部分。
- 8.4.2 遇到电动机有过热现象要及时停车，排除故障后再继续运行，电机轴承润滑要良

好。

8.4.3 各部分电刷，其接触面要保持清洁，调整电刷压力，使其接触面积不小于 50%。

8.4.4 各控制箱、配电箱等经常保持清洁，及时清扫电器设备上的灰尘。

8.4.5 各安全装置的行程开关的触点开闭必须可靠，触点弧坑应及时磨光。

8.4.6 每年摇测保护接地电阻两次（春、秋），保证不大于  $4\Omega$ 。

### 8.3 The maintenance of metal structure

8.3.1 Try the best to make the component avoid to be deformed and damaged when in transportation.

8.3.2 In the lifetime of mental structure, examine and repair and maintain it periodically in order to avoid rusting.

8.3.3 Examine whether the structure joint bolt, soldering seam and component is damaged, deformed, loose and other situations.

8.3.4 Spray and brush the oil once in every other year or every 1~2 years.

### 8.4 The maintenance of electrical system

8.4.1 Examine whether all power cables and electric wires are damaged or not frequently. Bind up and change the damaged part timely.

8.4.2 If the electric motor is overheating, stop it at once. Continue to operate after rectifying the trouble. The axle bearing of electric machine should be well.

8.4.3 Dynamo brush of each part and mating surface should be clean. Adjusting brush pressure and make sure its contacting area is not less than 50%.

8.4.4 Keep each control box and distributing box clean frequently. Clear the dust of electrical equipment timely.

8.4.5 The contact switching of over travel limit switch of each safety device should be reliable. The contact crater should be polished timely.

8.4.6 Every year in spring and in autumn earth resistance for rotating protection should be guaranteed not greater than  $4\Omega$ .

## 8.5 钢丝绳

### 综述

钢丝绳虽然结构紧密，外观粗壮，也会老化和磨损，一旦老化和磨损，便会迅速损坏。如果使用者不加注意，钢丝绳的损坏会带来严重的后果（人员和设备）。定期检查钢丝绳，便能随时掌握其变化情况，在起重设备中，钢丝绳应被看作一种消耗品，强度

降低时应予以更换，不宜继续。

钢丝绳的安装：

新更换的钢丝绳一般应与原安装的钢丝绳同类型、同规格。如采用不同类型的钢丝绳，用户应保证新钢丝绳不低于原选钢丝绳的性能，并与卷筒和滑轮上的槽形相适应。当从卷轴或钢丝绳卷上抽出钢丝绳时，应采取措施防止钢丝绳打环，扭结、弯折或粘上杂物。在起重机械上的钢丝绳投入使用之前，用户应确保与钢丝绳工作有关的各种装置已安装就绪并运转正常。为使钢丝绳稳定就位，应使用大约10%的额定载荷对机械进行若干次运转操作。

## 8.5 Steel rope

### Introduction

Steel rope, though compact in structure, will get aging and worn. Once aged or worn, it will be easily damaged. So if users do not notice that, the damage of steel rope cause serious consequence to personage and equipment. So you should check the steel rope regularly and understand its changes. Steel rope is considered as one consumable, so if its strength reduces, replace it instantly.

### Steel rope installation

The new steel rope to replace the worn rope should be the same specification and type as the original one. Users also should make sure that the new steel rope performance should not be worse than the original one and be fit for the drum and slot on pulley. When pulling out steel rope from drum, do special measures to avoid rope kink or bent. Before using steel rope, guarantee that all devices related to steel rope are well installed. After all installation of steel rope, debug the devices using about 10% rated load.

#### 1、安装新钢丝绳

- 1) 在干净的场地上，把钢丝绳从线盘里全部展开，避免扭曲如果不能把绳完全展开，可以把它放成大绳圈，在这种情况下，卷筒缠绕钢丝绳时防止危险的形成。
- 2) 检查钢丝绳的长度。
- 3) 借助一根绳索，将钢丝绳缠绕在卷筒上，并用全部线夹将钢丝固定在卷筒上，并使钢丝绳超过最后一个夹头**3cm**（夹头螺钉的拧紧力矩**9mdaN**）。
- 4) “起升上升”动作和缠绕钢丝绳**4** 至**10** 圈，并用手套或棉纱将钢丝绳拉得很紧。
- 5) 检查限位器的调节，必要时使之进一步完善。

1. Install new steel rope

- 1) Extend the steel rope completely, avoiding rope bending or kink.
- 2) Check the steel rope length.
- 3) Wind steel rope and fix it by rope clips on a drum. The steel rope over the last clip should be 3cm (clip screw tightening moment is 9mdaN)
- 4) Conduct the “Lift-up” operation about four to ten circles and pull it to make it tightened using gloves or cotton.
- 5) Check the adjustment of position stopper. If necessary, complete to adjust it.

8.5.1 钢丝绳基本知识

8.5.1.1 钢丝绳的结构

如图 8-1 所示，钢丝绳是由一定数量的钢丝一层或多层的股绕成螺旋形而形成的结构。

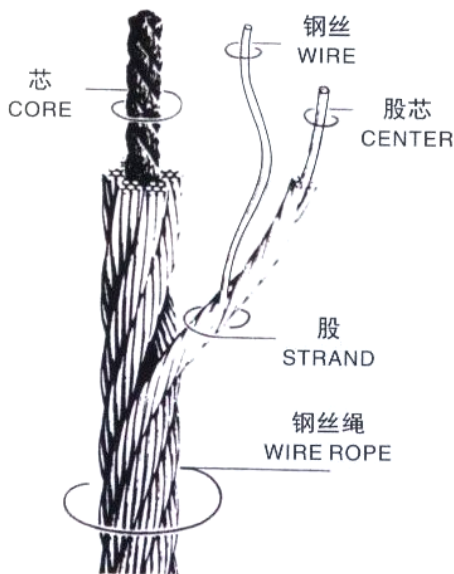
8.5.1.2 钢丝绳的捻向(见图 8-2)

8.5.1 Basics of rope

8.5.1.1 Rope structure

As shown in Figure 8-1, steel wire is a helical structure composed of a number of shares of one or more layers.

8.5.1.2 Rope lay direction (see Figure 8-2)



8-1

Fig 8-1



图 8-2

Fig8-2

### 8.5.1.3 钢丝绳直径测量

在测量钢丝绳直径时，注意正确的测量方法，如图 8-3 所示。

#### 8.5.1.3 Rope diameter measurement

When measuring the diameter of the rope, use correct measurement method, as shown in Figure 8-3.

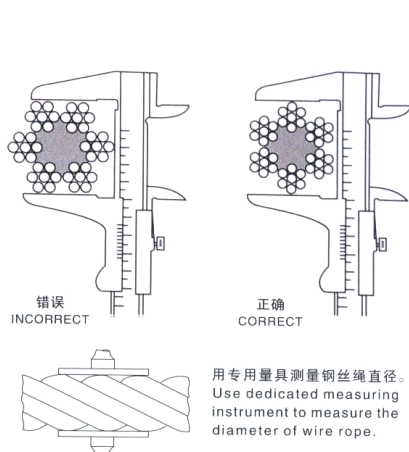


图 8-3

Fig 8-3

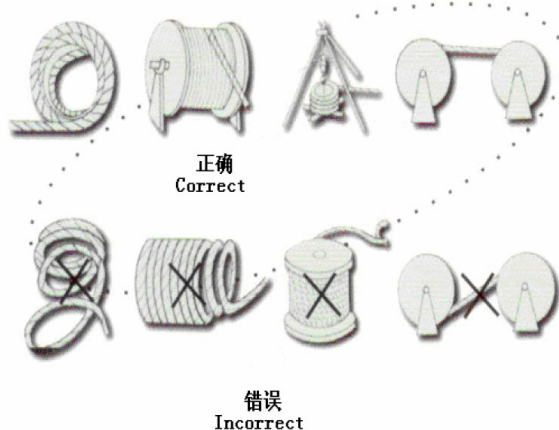


图 8-4

Fig 8-4

### 8.5.1.4 钢丝绳的解卷

解卷时应将绳盘放在专用的支架上，也可用一根钢管穿入绳盘孔，两段套上绳套吊起，将绳盘缓缓转动，如图 8-4 所示。

### 8.5.1.5 钢丝绳夹

#### 8.5.1.5.1 钢丝绳夹的布置

钢丝绳夹应按图 8-5 所示把夹座扣在钢丝绳的工作段上，U 形螺栓扣在钢丝绳的尾段上。钢丝绳不得在钢丝绳上交替布置。

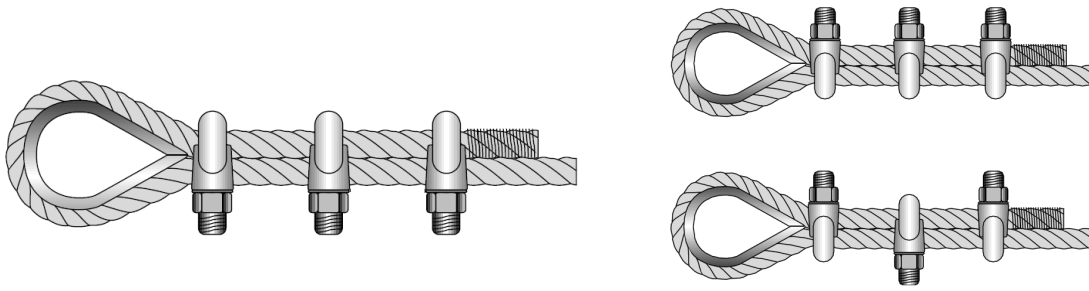
#### 8.5.1.4 Rope unwinding

When unwinding the rope, put rope on a special support, or lift the rope up with a steel bar penetrating through hole of rope with rope sleeve at two ends, and move rope block slowly, as shown in Figure 3.1-4.

### 8.5.1.5 Rope clips

#### 8.5.1.5.1 Rope clamp arrangement

As Figure 3.1-5, put clip seat at the working section of wire rope, with U-bolt buckling tail rope. Wire ropes should not be arranged alternately.



钢丝绳夹正确安装

钢丝绳夹错误安装

图 8-5

Right way

Wrong way

图 8-5 Fig 8-5

#### 8.5.1.5.2 钢丝绳夹的数量

对于符合本标准规定的适用场合，每一连接处所需钢丝绳夹的最少数量，推荐如表 8-1 所示。

#### 8.5.1.5.2 Number of wire rope clips

For suitable occasions compliant with this standard, the minimum number of wire rope clips required for each connection, is recommended as shown in Table 8-1.

表 8-1 钢丝绳夹的数量

Figure 8-1 Quantity of rope clip

绳夹公称尺寸 mm (钢丝绳公称直径 dr) Rope clip nominal size (mm)	钢丝绳夹的最少 数量 (组) Minimum number (group)	绳夹公称尺寸 mm (钢丝绳公称直径 dr) Rope clip nominal size (mm) (Nominal diameter dr)	钢丝绳夹的最少 数量 (组) Minimum number (group)
≤19	3	>38~44	6
>19~32	4	>44~60	7
>32~38	5		

#### 8.5.1.5.3 钢丝绳夹间的距离

如图 8-6 所示，钢丝绳夹间的距离 A 等于 6~7 倍钢丝绳直径。

#### 8.5.1.5.3 Distance between wire rope clips

As shown in Figure 3.1-6, distance A between rope clips is equal to the 6 to 7 times the

rope diameter.

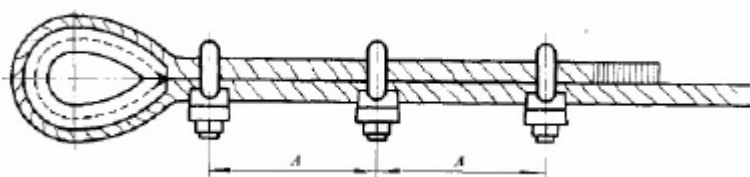


图 8-6 Fig 8-6

#### 8.5.1.5.3 钢丝绳夹的紧固方法

紧固绳夹时须考虑每个绳夹的合理受力，离套环最远处的绳夹不得首先单独紧固。离套环最近的绳夹（第一个绳夹）应尽可能靠近套环，但仍须保证绳夹的正确拧紧，不得损坏钢丝绳的外层钢丝。

#### 8.5.1.5.3 Fastening methods of rope clip

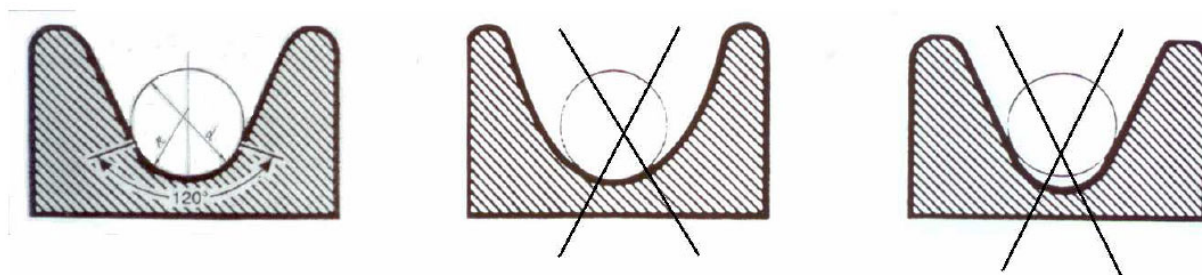
When fastening the rope, reasonable force of each rope clip needs to be considered. The clip at the most distant from socket ring rope should not be separately fastened at first. The nearest rope clip from socket ring (first rope clip) should be set as close to the ring. Make sure the correct tightening of rope clips, without damaging outer wires.

#### 8.5.1.5.4 钢丝绳直径与轮槽的关系

合适的轮槽与钢丝绳应为图 8-7a 所示。轮槽过大（图 8-7b），会增加钢丝绳及金属绳芯疲劳断丝；轮槽过小（图 8-7c），会严重磨损钢丝绳。轮槽半径  $R$  与钢丝绳公称直径  $d$  之比应为 0.525~0.559 之间。

#### 8.5.1.5.4 Relationship between the rope diameter and groove

Suitable wheel groove of rope is shown in Figure 8-7a. Too large groove (Figure 8-7b), will increase the rope and its mental core fatigue and break. Too small groove (Figure 8-7c), will badly worn rope. The ratio between wheel groove radius  $R$  and diameter  $d$  should be between 0.525 ~ 0.559.



正确  
a) Right

(b) 错误  
(b) Wrong

(c) 错误  
(c) Wrong

图 8-7 钢丝绳与轮槽的关系

Figure 8-7 Relationship between the rope diameter and groove

## 8.5.2 钢丝绳的安装

当从卷筒上抽出钢丝绳时，应采取措施防止钢丝绳打环、扭结、弯折或粘上杂物。在钢丝绳投入使用之前，用户应确保与钢丝绳工作有关的各种装置已安装就绪并运转正常。新更换的钢丝绳应与原安装的钢丝绳同类型、同规格。如钢丝绳系由较长的绳上切下，应在切断的两端进行处理，以防切断处引起钢丝绳的松散。

## 8.5.3 钢丝绳的报废

### 8.5.3.1 断丝的性质和数量

表 8-2 考虑了这些因素，因此，当与（2）～（19）款中的因素结合起来考虑时，它适用于各种结构的钢丝绳。

### 8.5.3.2 绳端断丝

当绳端或其附近出现断丝时，即使数量很少也表明该部位应力很大，可能是由于绳端安装不正确造成的，应查明损坏原因。如果绳长允许，应将断丝的部位切去重新安装。

## 8.5.2 Installation of wire rope

When withdrawn from drum, wire rope should be taken measurement to prevent fighting ring, kink, bend or glue debris. Before using rope, the user should ensure that a variety of devices related to wire rope has been installed in place and functioning properly. The new wire rope should be replaced with the same type and specification of the original rope. If the rope is too long and needs to be cut a little, the two ends of rope after cut should be treated to prevent loosing the whole rope.

## 8.5.3 Scrapped rope

### 8.5.3.1 Nature and number of broken wires

Table 8-2 refers to these factors, which are suitable for all kinds of steel rope when combined with Item (2) to (19).

### 8.5.3.2 Break of rope end

When it appears break near rope end, even if it is a small number, also indicates that this part is stress a lot. The reason may be the rope is not installed correctly. Identify the causes of damage and cut the broken part and reinstall if possible.

## 8.5.3.3 断丝的局部聚集

如果断丝紧靠一起形成局部聚集，则钢丝绳应报废。如这种断丝聚集在小于  $6d$  的绳长范围内，或者集中在任一支绳股里，那么，即使断丝数比表 8-2 列的数值少，钢丝绳也应予以报废。

## 8.5.3.4 断丝增加率

在某些使用场合，疲劳是引起钢丝绳损坏的主要原因，断丝则是在使用一个时期以后才开始出现。当断丝数逐渐增加，其时间间隔越来越短时，为了判判断断丝的增加率，应仔细检验并记录断丝增加情况。利用这个规律可用来确定钢丝绳未来报废的日期。

## 8.5.3.3 Partially gather of broken wire

If the broken wire is close together partially, the rope should be scrapped. If such gather is in less than  $6d$  of rope length, or focuses on any strand, the rope should also be scrapped even if the broken wires are less than the number listed in Table 8-2.

## 8.5.3.4 The increasing of broken wire

In some occasions, fatigue is the main cause of damage to wire rope, while wire break begins to appear after a period of use. When the number of broken wires increasing and its intervals becoming shorter, carefully examine and record the increase of broken wires to figure out the increase rate of broken wires. This rule can be used to determine future retirement date if rope.

表 8-2 钢丝绳允许断丝数

外层绳股承载 钢丝数 $n$ Bearing number of outer Wire strand $n$	起重机械中钢丝绳必须报废时与疲劳有关的可见断丝数 The number of visible broken wire rope related to fatigue for lifting machinery when rope must be scrapped							
	机构工作级别 M1、M2、M3、M4 Mechanism level M1, M2, M3, M4				机构工作级别 M5、M6、M7、M8 Mechanism level M5, M6, M7, M8			
	交互捻 Regular lay		交互捻 Regular lay		交互捻 Regular lay		交互捻 Regular lay	
	长度范围 Length range				长度范围 Length range			
	6d	30d	6d	30d	6d	30d	6d	30d
$n \leq 50$	2	4	1	2	4	8	2	4
$51 \leq n \leq 75$	3	6	2	3	6	12	3	6

$76 \leq n \leq 100$	4	8	2	4	8	16	4	8
$101 \leq n \leq 120$	5	10	2	5	10	19	5	10
$121 \leq n \leq 140$	6	11	3	6	11	22	6	11
$141 \leq n \leq 160$	6	13	3	6	13	26	6	13
$161 \leq n \leq 180$	7	14	4	7	14	29	7	14
$181 \leq n \leq 200$	8	16	4	8	16	32	8	16
$201 \leq n \leq 220$	9	18	4	9	18	38	9	18
$221 \leq n \leq 240$	10	9	5	10	19	38	10	19
$241 \leq n \leq 260$	10	21	5	10	21	42	10	21
$261 \leq n \leq 280$	11	22	6	11	22	45	11	22
$281 \leq n \leq 300$	12	24	6	12	24	48	12	24
$n > 300$	$0.04n$	$0.08n$	$0.02n$	$0.04n$	$0.08n$	$0.16n$	$0.04n$	$0.08n$

注:

(1) 填充钢丝不能看作承载钢丝，因此要从检验数中扣除。多层股钢丝绳仅考虑可见的外层绳股，带钢芯的钢丝绳，其绳芯看作内部绳股而不予考虑。

(2) d 为钢丝绳公称直径，单位 mm。

Note:

(1) Filler wire cannot be regarded as bearing steel therefore it needs to be deducted from the number of checkout. For multi-strand wire, the visible outer strands are only considered. The rope wire rope with steel core which is regarded as an internal rope strand would not be considered.

### 8.5.3.5 绳股断裂

如果出现整根绳股的断裂，则钢丝绳应报废。

### 8.5.3.6 绳芯损坏而引起的绳径减小

当钢丝绳的纤维，芯损坏或钢芯（或多层结构中的内部绳股）断裂而造成绳径显著减小，钢丝绳应报废。

微小的损坏，特别是当所有各绳股中应力处于良好平衡时，用通常的检验方法可能是不明显的。然而这种情况会引起钢丝绳的强度大大降低。所以，有任何内部细微损坏的迹象时，均应对钢丝绳内部进行检验予以查明。一经证实损坏，则该钢丝绳，就应报废。

### 8.5.3.5 Strand break

If it occurs to the whole of strands fracture, the rope should be scrapped

#### 8.5.3.6 Rope diameter reduced caused by cord damage

When the rope diameter is reduced because of the damage on rope fiber, core and steel core (or internal strands in multilayer structure) the rope should be scrapped.

Slight damage may not be obvious in usual test methods, particularly when the stress of all strands in a good balance. However, this situation will lead to reduce greatly the strength of the rope. Hence, check the internal rope when there are any subtle signs of internal damage on rope. After proven out the damage, the rope should be scrapped.

#### 8.5.3.7 外部磨损

钢丝绳外层绳股的钢丝表面的磨损,是由于它在压力作用下与滑轮或卷筒的绳槽接触摩擦造成的。这种现象在吊载加速或减速运动时,在钢丝绳与滑轮接触的部位特别明显,并表现为外部钢丝磨成平面状。

润滑不足或不正确的润滑以及存在灰尘和砂粒都会加剧磨损。

磨损使钢丝绳的断面积减小而强度降低。当钢丝绳直径相对于公称直径减小 7%或更多时,即使未发现断丝,该钢丝绳也应报废。

#### 8.5.3.8 弹性降低

在某些情况下,钢丝绳的弹性会显著降低,继续使用是不安全的。钢丝绳的弹性降低较难发现,如检验人员有任何怀疑,应征询钢丝绳专家的意见。

虽未发现断丝,但钢丝绳明显的不易弯曲和直径减小比起单纯是由于钢丝磨损而引起的减小要严重得多。这种情况会导致在动载作用下钢丝绳突然断裂,故应立即报废。

#### 8.5.3.7 External wear

Wear of outer surface of wire rope strands, is because of its frictional under pressure contacting with the rope groove of pulley or drum. This phenomenon is evident at the contacting part of rope and pulley when in acceleration or deceleration, with the outer wire is rubbed into flat surface.

Lack of lubrication or improper lubrication and existence of dust and sand will increase wear.

Wear will lead to the reduction of rope section and strength. When the rope diameter is reduced 7% or more relative to the nominal diameter of, the rope should be scrapped even if not found broken wires.

### 8.5.3.8 Elasticity reduction

In some cases, the elastic rope is significantly reduced, and continuing use is unsafe. Elasticity reduction of rope is difficult to find, if personnel who have any doubt should consult rope experts.

Although the rope is not found to be broken, more serious is that the rope cannot be bended easily or its diameter is reduced. This case will result at sudden rupture of rope so the rope should be immediately scrapped.

### 8.5.3.9 外内部腐蚀

外部钢丝的腐蚀可用肉眼观察。当表面出现深坑，钢丝相当松弛时应报废。

如果有任何内部腐蚀的迹象，则应由主管人员对钢丝绳进行内部检验。若确认有严重的内部腐蚀，则钢丝绳应立即报废。

### 8.5.3.10 波浪形

如图 8-8 所示，出现波浪形时，在钢丝绳长度不超过  $25d$  的范围内， $d_1 \geq \frac{4}{3}d$  则钢丝绳应报废。式中  $d$  为钢丝绳的公称直径， $d_1$  是钢丝绳变形后包络的直径。

### 8.5.3.9 External and internal corrosion

External corrosion can be visually observed. When the surface is pitted and the rope is considerably slack, the rope should be scrapped.

If there are any signs of internal corrosion of rope, responsible person should be carried out internal inspection. If it is confirmed as serious internal corrosion, the rope should be immediately scrapped.

### 8.5.3.10 Wavy

As shown in Figure 8-8, if the rope appears to be wavy, and the rope length is less than  $25d$ ,  $d_1 \geq \frac{4}{3}d$  the rope should be scrapped.  $d$  means nominal diameter of rope,  $d_1$  is diameter of rope after deformed.

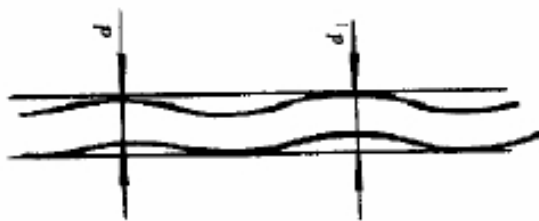


图 8-8 波浪变形

Fig. 8-8 Wave deformations

#### 8.5.3.11 笼状畸变

这种变形出现在具有钢芯的钢丝绳上,当外层绳股发生脱节或者变得比内部绳股长的时候就会发生这种变形,如图 8-9 所示。笼状畸变的钢丝绳应立即报废。

#### 8.5.3.11 Cage-like distortion

This distortion occurs on wire with steel core. This deformation occurs when outer strands are out of line or longer than internal strands, as shown in Figure 8-9 divorced or outer strands occur. Cage-like distorted rope should be immediately scrapped.



图 8-9 笼状畸变

Figure 8-9 Cage-like distortion

#### 8.5.3.12 绳股挤出

这种状况通常伴随笼状畸变一起产生,绳股被挤出说明钢丝绳不平衡,如图 8-10 所示。绳股挤出的钢丝绳应立即报废。

#### 8.5.3.12 Extrusion of strands

This condition is usually produced accompanying with a cage-like distortion. The strands are squeezed out, which means the rope is imbalanced, as shown by 8-10. The rope with extruded strands should be immediately scrapped.

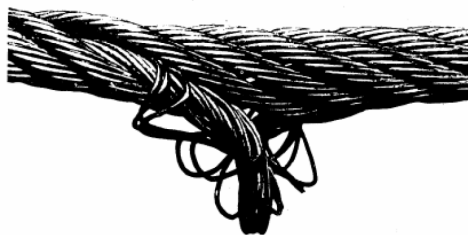


图 8-10 绳股挤出

Fig 8-10 Strand extrusion

#### 8.5.3.13 钢丝挤出

此种变形是一部分钢丝或钢丝束在钢丝绳背着滑轮槽的一侧拱起形成环状，这种变形常因冲击载荷而引起，如图 8-11 所示。若此种变形严重时，则钢丝绳应报废。

#### 8.5.3.13 wire extrusion

Such distortion is part of the wire rope or wire bundles in the side of the pulley groove backs arched to form a ring, often due to the deformation caused by the impact load, as shown in Figure 8-11. If this deformation is serious, the rope should be scrapped.



图 8-11 钢丝挤出

Fig 8-11 Steel wire extrusion

#### 8.5.3.14 绳径局部增大

钢丝绳直径有可能发生局部增大，并能波及相当长的一段钢丝绳。绳径增大通常与绳芯畸变有关(如在特殊环境中，纤维芯因受潮而膨胀)，其必然结果是外层绳股产生不平衡，而造成定位不正确，如图 8-12 所示。绳径局部严重增大的钢丝绳应报废。

#### 8.5.3.14 Partially increase of rope diameter

Wire diameter may occur partially increase which may influence quite a long rope. Rope diameter increases is normally associated with distortion of rope core (such as in special circumstances, the fiber core swells due to damp), and the inevitable result is that the outer strands is unbalanced and consequently incorrect positioning, as shown in Figure 8-12. If part

of rope diameter is seriously increased the rope should be scrapped.



图 8-12 绳径局部增大

Figure 8-12 Partial increase of rope diameter

#### 8.5.3.15 扭结

扭结是由于钢丝绳成环状在不可能绕其轴线转动的情况下被拉紧而造成的一种变形。其结果是出现捻距不均而引起格外的磨损，严重时钢丝绳将产生扭曲，以致只留下一极小一部分钢丝绳强度，如图 8-13 所示。严重扭结的钢丝绳应立即报废。

#### 8.5.3.15 Kink

A rope is deformed due to the tightening when the rope with a kink cannot rotate about its axis. The result is the emergence of wear caused by uneven lay distance, and in more terrible situation, the rope will be distorted, leaving only a tiny part of rope strength, as shown in Figure 3.3-6. The rope with a serious kink should be immediately scrapped.



图 8-14 钢丝绳扭结

Figure 8-14 Rope kink

#### 8.5.3.16 绳径局部减小

钢丝绳直径的局部减小常常与绳芯的断裂有关。应特别仔细检验靠绳端部位有无此种变形，如图 8-15 所示。绳径局部严重减小的钢丝绳应报废。

#### 8.5.3.16 Partial decrease of rope diameter

Partially reduced diameter of is related to rope core fracture. Particularly inspect carefully the rope end parts for such distortion, as shown in Figure 8-15. Partially serious reduced diameter rope should be scrapped.



图 8-15 绳径局部减

Figure 8-15 Partial decrease of rope diameter

#### 8.5.3.17 部分被压扁

钢丝绳部分被压扁是由于机械事故造成的，如图 8-16 所示。严重时则钢丝绳应报废。

#### 8.5.3.17 Partial flattened

Rope is partially flattened due to mechanical accidents, as shown in Figure 8-16. When the condition is serious the rope should be scrapped.



图 8-16 部分被压扁

Figure 8-16 Partial flattened

#### 8.5.3.18 弯折

弯折是钢丝绳在外界影响下引起的角度变形，如图 8-17 所示。这种变形的钢丝绳应立即报废。

#### 8.5.3.18 Bend

Rope is bent to deform by the impact, as shown in Figure 3.3-9. This deformed rope should be immediately scrapped.



图 8-17 钢丝绳的弯折

Figure 8-17 Rope bent

#### 8.5.3.19 由于热或电弧的作用而引起的损坏

钢丝绳经受了特殊热力的作用其外表出现可资识别的颜色时，该钢丝绳应予报废。

#### 8.5.3.19 damage caused by heat or electric arc

Rope with distinguishing colors caused by special heat should be scrapped.

### 8.5.4 钢丝绳的维护保养

钢丝绳使用一段时间后，润滑油脂会逐渐减少，且钢丝绳表面会沾有尘埃、碎屑等污物，引起钢丝绳和滑轮的磨损以及钢丝绳生锈。因此，应定期清洗和加油。简易的方法就是先用钢丝刷刷掉钢丝绳表面的污物，把加热熔化的润滑油脂均匀地涂抹在钢丝绳表面，也可把机油喷浇在钢丝绳表面。

使用钢丝绳必须定期检查并做好记录，除上述清洗加油外，还应检查钢丝绳的磨损程度、断丝情况、腐蚀程度以及吊钩、滑轮槽等部件磨损情况。如发现异常必须及时调整或更换。

### 8.5.4 Maintenance of rope

After being used for a period of time, the lubricating grease of rope will gradually decrease and the rope surface will be stained with dust, debris and dirt, causing the wear and rust of rope. Therefore, regular clean and add grease on rope. One easy way is to brush off the dirt on rope surface firstly, and then paint the grease heated to melt evenly on the surface, or spray oil poured on it.

Regularly check and make a record during the use of steel rope. In addition to the above cleaning and adding-oil, also check degree of wear, wire break, degree of corrosion, and wear of hooks, pulleys groove, and other components. If there is any abnormal to the above components, replace or adjust timely.

## 8.6 回转支承

回转支承紧固螺栓的定期检查（型号013.50.1830）

检查次数：回转支承运转100 小时后，应检查螺栓的预紧力，以后每运转500小时检查一次，必须保持足够的预紧力。同时每次拆装塔吊时都应检查其预紧力。

检查方法：塔机在运行中时，应确保被检查的螺栓不受由载荷和平衡重产生的拉伸作用的影响。

使用力矩扳手（如果必要的话也可使用力矩增力扳手）按照表8-1中所列的螺栓所对应的力矩值检查紧固力矩。

**必要更换：**在检查过程中，可能会出现有一个或几个螺栓的紧固力矩值与表中所列数值不符，在这种情况下，就有必要更换其中部分甚至全部的螺栓。

**整体更换：**在回转齿圈组件中所使用的螺栓每隔七年或工作14000 小时以后应全部更换一次。

**螺栓的再紧固：**无论是在更换螺栓后，还是（通常是用新螺栓）重新组装了回转支承，拧紧安装螺栓，应在180°方向对称地连续进行，最后通过一遍。保证圆周上的螺栓有相同的预紧力。

## 8.6 Slewing bearing

The regular inspection of slewing bearing tightening bolt (type: 013.50.1830)

**Inspection number: after 100h operation of slewing bearing, check the bolt pre-tension force. After this check it once after each 500h to keep enough pre-tension force. In each dismantlement, you should check it also.**

Checking method: when tower crane is working, make sure that the inspected bolt is not influenced by the stretching effect from load and counterweight.

Use the moment spanner (if necessary use the moment strengthening spanner) according to the correspondent moment value for each bolt in Table 8-1.

Necessary replacement: during inspection, there may be some tightening moment values of bolts which are different from the table. For this case, replace the bolts.

Whole replacement: replace the bolts in slewing gear ring every seven years or after working 14000 hours.

Re-tightening of bolt: either after the replacement of bolts, or after e-assembling the slewing bearing, tighten the installing bolt at 180° direction symmetrically for the last time. Guarantee the bolts on the ring have the same pre-tension force.

表8-1 Table 8-1

螺栓直径 $\phi$ (mm)	螺栓类型 10.9		
	紧固力矩(Kg.m)		
	最大	额定	最小
$\Phi 20$	55	46	40
$\Phi 22$	71	65	58
$\Phi 24$	95	85	70
◆ $\Phi 27$	◆ 144	◆ 124	◆ 110
$\Phi 33$	248	220	190

◆为本塔机回转机构连接选用螺栓。此螺栓应每周检查一次。如果有松动现象请按照表中所给力矩拧紧。

◆ **Table 8-1 is the connection bolt for tower crane slewing mechanism. This bolt should be check at least once a week. If there is loose condition, tighten it according to the moment in the table.**

## 8.7 起重机维修时间的规定

### 8.7.1 日常保养（每班进行）

表 8-3

## 8.7 The stipulation of maintenance time of crane

### 8.7.1 Current maintenance (carry out in each shift)

Table 8-3

序号 No.	项 目 Item	要 求 Requirement
1	检查配电箱及电线 Examine the distributing box and the electric wire	各接线头，保险丝的接头，如有移位，松动，应紧固，电线破损处应用绝缘带包扎或换线更新。 If each connector lug and the joint of fuse shifts or become loose, tighten it. Bind it up or change it with insulated tape in the damaged part.
2	检查制动器 Examine the brake	制动应灵敏可靠，各连接部分不应有斜卡现象，各紧固件无松动现象，电磁铁的板面应清洁，弹簧杆作用良好，制动闸瓦与制动轮的间隙不大于0.5~0.8mm，制动时，接触应均匀，接触面积不得小于全面积的80%。

		Brake should be flexible and reliable. There should not appear slanting calorie in each joint part. Fastening piece should not be loose. The pan of electromagnet board should be clean. The function of spring beam is well. The clearance between brake block and brake wheel should not be more than 0.5~0.8mm. When braking, contact evenly. The contact area should not be smaller than 80% of gross area.
3	各部连接及钢丝绳 joint of each part and cable wire	各连接处不得松动，检查钢丝绳磨损，断丝程度，断股超过 5%均应换绳。 Each joint should not be loose. Examine degree of wear and degree of filament break of cable wire. When strand break is more than 5%, change the rope.
4	润滑工作 Lubrication	按润滑表执行。 Carry out according to the lubrication table
5	清洗工作 Wash	每天作业完应清除各电机及传动机构外部灰尘污垢。 Clear the dust and dirt of each electric machine and drive gear after operating every day.

8.7.2 一级保养（每作业 50 小时进行） 表 8-4

8.7.2 The first grade maintenance (carry out after operating 50 hours) Table 8-4

序号 No.	项 目 Item	要 求 Requirement
1	检查各钢丝绳固定 Examine the fasten of each cable wire	检查钢丝绳的受力是否均匀，各绳扣是否有松动。 Examine whether the cable wire is stressed evenly and whether the bale sling is loose.
2	检查各传动机构 Examine each drive mechanism	检查各联轴器，法兰盘的固定螺栓是否松动，齿轮传动啮合情况。 examine each coupling, examine whether fixed bolt of flange plate is loose and examine the gear drive and engaging situation.
3	检查减速器 Examine speed reducer	是否缺油，及时补加或换油，是否有不正常现象或噪音过大，温升过高。 Whether lack oil, add or change oil timely. Whether there is any abnormal phenomenon or the noise is too loud and the temperature is too high.

## 8.7.3 二级保养（每作业 200 小时进行）

表 8-5

## 8.7.3 The second grade maintenance (carry out after operating 200 hours)

Table 8-5

序号 No.	项 目 Item	要 求 Requirement
1		进行一级保养的全部工作。 Do all the works of the first grade maintenance
2	检查钢结构 Examine steel structure	各部件不应有扭曲，变形，裂纹，各紧固件不应有松动，各焊缝不应有裂纹。 Each component should not twist, deform, and bull crack. Each fastening should not loose. Each soldering seam should not have bull crack.
3	检查制动器 Examine brake	清洗制动器的油污，检查铆钉有无松动过高现象，制动器磨损情况，电磁铁是否松动，受潮发热。 Wash the dirt of brake. Examine whether the clinch loose and the clinch is too high. Examine whether the brake is worn, and whether the electromagnet loose or it is damped and heated up.
4	检查各轴承 Examine each bearing	各轴承是否有损伤，是否缺油，应更换损坏补加润滑油。 Whether each bearing is damaged, and whether it lacks oil. Change the damaged part and add lubrication oil.
5	检查回转支承润滑 Examine circuit supporter lubrication	补加回转支承润滑脂。 Add slewing supporter grease lubricant.

8.7.4 三级保养（每作业 400 小时进行）

表 8-6

8.7.4 The third grade maintenance (carry out after operating 400 hours) Table 8-6

序号 No.	项 目 Item	要 求 Requirement
1		进行一、二级保养全部工作 Do all the works of the first and the second grade
2	清洗各减速器 Wash each speed reducer	放出旧齿轮油，清洗减速箱，检查齿轮磨损情况，予以调整更换。 Discharge old gear oil; clear positive speed gearbox; examine the wear situation of gear, and adjust and change it.
3	检查各滑轮 Examine each pulley	检查各部滑轮、磨损情况，清洗更换润滑脂，更换损坏滑轮。 Examine each pulley and the wear situation; wash and change grease lubricant; change the damaged chain wheel.
4	检查跑车 Examine trolley movement	检查滚轮润滑磨损情况，更换润滑脂，磨损严重的滚轮应更换。 Examine the wear of rolling wheel lubrication; change grease lubricant; change the heavy-worn rolling wheel.
5	检查回转支承 Examine slewing supporter	检查回转支承运转情况，更换其润滑脂。 Examine the operation situation of supporter, and change the grease lubricant.
6	整体 Integral	更换或解决认为有必要予以解决的部件或构件。 Change or solve the necessary parts or components.

8.7.5 起重机长期停放的维护与保养

起重机长期停放不用时，需进行如下的维护与保养：

(1) 能够入库存放的部件应入库存放在干燥处，存放前要涂装（涂防锈油或涂漆）保养；

(2) 不能入库存放的部件也应尽量存放在能够避雨、防潮处，无避雨处存放时，也应将诸如起升机构、牵引机构、电控柜等用防雨布罩上。存放前要对油漆剥落处进行补漆，对不涂油漆处如回转支承、销轴连接处、螺栓连接处等要涂防锈油防锈；

(3) 高强度螺栓涂防锈油后入库存放在干燥处；

(4) 所有外露电线、电缆等都要用防雨布包扎；

起重机长期存放后重新安装使用前，必须对其各机构减速箱中的润滑油、润滑脂进行更换，并按润滑表中的部位进行润滑；必须对其进行空载、静载、动载试验及对各种

安全装置进行调整（见有关调整方法）后方能进行吊装作业。

#### **8.7.5 The maintenance of crane when it is stopped for a long time**

When do not use the crane for a long time, do the following maintenance:

- (1) The parts which could put in warehouse should put in the dry place of the warehouse. Do painting and dressing (paint rust proof oil or paint dope) before putting in the warehouse;
- (2) The parts which could not put in warehouse, try the best to put it in the rain proof and damp proof place. If there is no rain proof place to store, use rain cloth to cover such gears as hoisting gear, drag gear, electric control cabinet and so on. Oil paint flaking should be painted again before storing. Paint rust proof oil in the place which do not paint such as slewing supporter, pin shaft joint, bolt joint and so on;
- (3) Store the high strength bolt in the dry place after painting rust proof oil;
- (4) Bind up all the outside air wire, cable and so on with rain proof cloth;

After long time storage, change the lubrication oil and grease lubricant of speed reducer box of each machine before reassembling to use. Lubricate the place stipulated in lubrication table; Do mount operation after no load; dead weight, dynamic load trial and various safety device adjustments (see related adjustment ways).

If the crane had been in stock for long time before it come into use, lubrication oil and grease of every gear box should be changed, and then they should be lubricated according to the lubrication table: the crane should be test for unloading, static loading, movement loading and to adjust each kind of safety device. (Please refer to the adjustment introduction), and then it can come into lifting operation.

### 8.8 起重机常见故障与排除

序号	故障现象	故障原因	排除方法
1	制动器打滑产生吊钩下滑和变幅小车制动后向外溜车	制动力矩过小 制动轮表面油污和制动时间过长	调整制动器弹簧压力 清除油污，调小制动瓦间隙值
2	制动器负载冲击过猛	制动时间过短 闸瓦两侧间隙不均匀	加大制动瓦的间隙或增大液压推杆行程，把闸瓦调整均衡
3	制动器运转过程中发热冒烟	制动闸瓦间隙过小	加大制动瓦间隙
4	减速器温度过高	润滑油缺少或过多	注意适量增减油量
5	减速器轴承温度过高	主要是润滑脂过量或太少 润滑脂质量差 轴承轴向间隙不符合要求或轴承面损坏	按规定更换润滑脂并适量重新调整轴承间隙，更换轴承
6	减速器漏油	连接部位贴合面的密合性，轴端密封圈磨坏	更换密封圈
7	顶升无力或不能顶升	A. 油泵严重内泄 B. 溢流阀调定压力 C. 手动换向阀阀芯过度磨损 D. 溢流阀卡死	修复或更换损坏件，按有关规定调节压力
8	顶升太慢	A. 油泵磨损，效率下降 B. 油箱油量不足或滤油器堵塞 C. 手动换向阀，阀杆与阀孔磨损严重 D. 油缸活塞密封有损伤出现内泄漏	修复或更换损坏件 加足油量或清洗滤油器 检修或换阀 更换油封
9	顶升升压时出现噪声振动	滤油器堵塞	清洗滤油器
10	顶升系统不工作	电机转向与油泵转向不合	改变电机的旋转方向
11	顶升时发生颤动爬升	A. 油缸活塞空气未排空 B. 导向机构有障碍	按有关规定排气
12	顶升有负载后下降	A. 缸头上的锁向阀出现故障 油缸活塞密封圈损坏	排除故障 更换密封件

13	变幅机构不能起动	<ol style="list-style-type: none"> <li>1. 控制接线错误</li> <li>2. 电机绕组相间短路接地或断路</li> <li>3. 电机电压过低</li> <li>4. 绕组接线错误</li> <li>5. 电磁制动器未松动</li> <li>6. 负载过大或传动机构有故障</li> </ol>	<ol style="list-style-type: none"> <li>1. 核对接线图</li> <li>2. 测量电网电压</li> <li>3. 按各种速度供电找出短路, 断路部分予以修复</li> <li>4. 检查制动器电压及绕组是否有断路或卡住</li> </ol>
14	变幅机构有异常噪声振动过大	<ol style="list-style-type: none"> <li>1. 机械磨擦 <ol style="list-style-type: none"> <li>A. 定转子相磨</li> <li>B. 电机和减速箱不同心</li> </ol> </li> <li>2. 轴承严重缺油或损坏</li> <li>3. 齿轮箱内缺油</li> <li>4. 齿轮磨损</li> <li>5. 两相运动, 有啸啸声</li> </ol>	<ol style="list-style-type: none"> <li>1. 检查定转子间隙是否均匀</li> <li>2. 检查滑环是否磨损并更换</li> <li>3. 清洗轴承加新润滑油, 更换轴承</li> <li>4. 更换齿轮</li> <li>5. 切断电源检查并修复</li> </ol>
15	变幅电机温升过高或冒烟	<ol style="list-style-type: none"> <li>1. 负载过大</li> <li>2. 负载持续及工作不符合规定</li> <li>3. 两相运行</li> <li>4. 电源电压过低或过高</li> <li>5. 电机绕组接地或匝间相间短路</li> <li>6. 摩擦片间隙不对</li> <li>7. 制动和释放时间不对</li> <li>8. 电机通风堵塞, 温度升高</li> </ol>	<ol style="list-style-type: none"> <li>1. 测定子电流, 如大于额定值要减小负载</li> <li>2. 按规定进行运行</li> <li>3. 测量三相电流并排除故障</li> <li>4. 检查输入电压并纠正</li> <li>5. 找出原因并修复</li> <li>6. 按要求调节间隙</li> <li>7. 检查制动器电压及延迟断电器动作时间, 消除故障</li> <li>8. 保持通风道畅通</li> </ol>
16	变幅机构轴承过热	<ol style="list-style-type: none"> <li>1. 轴承烧坏</li> <li>2. 润滑脂过多或过少</li> </ol>	<ol style="list-style-type: none"> <li>1. 更换轴承</li> <li>2. 按要求加润滑脂</li> </ol>
17	变幅机构带电	<ol style="list-style-type: none"> <li>1. 电源线及接地线 接错</li> <li>2. 接地不良</li> <li>3. 电机引接线擦伤接地</li> </ol>	<ol style="list-style-type: none"> <li>1. 查出并纠正</li> <li>2. 接地要接触良好</li> <li>3. 查处并纠正</li> </ol>
18	变幅机构制动器失灵	<ol style="list-style-type: none"> <li>1. 制动力矩过小</li> <li>2. 摩擦片磨损间隙增大</li> </ol>	<ol style="list-style-type: none"> <li>1. 制动器弹簧断或失效须更换</li> <li>2. 励磁电压不足</li> </ol>
19	吊重无力电机不转	<ol style="list-style-type: none"> <li>1. 输入电压过低</li> <li>2. 交流接触器断线</li> </ol>	<ol style="list-style-type: none"> <li>1. 检查工作电压, 保证输入电压不低于 360V</li> <li>2. 接通线路</li> </ol>
20	电动机温度过高	<ol style="list-style-type: none"> <li>1. 主要操作次数太频繁</li> <li>2. 低速使用时间太长或起升刹车没打开</li> </ol>	<ol style="list-style-type: none"> <li>1. 应适量减少操作次数</li> <li>2. 检查起升刹车</li> </ol>

No.	The phenomenon of the breakdown	The cause of the breakdown	Clear way
1	Break skid makes the lift hook slide down and make the derricking car slide toward outside after breaking	Brake moment is too small; There has oily soil on the surface of break wheel and the break time is too long	Adjust the spring pressure of break; Clear the oily soil, and slow down the clearance of break shoe
2	The load shock of break is too violent	The break time is too short; The clearance of both sides of brake shoe is uneven	Increase the clearance between break shoe or increase the travel of hydraulic pushing rod
3	Heat up and smoke in the course of break operation	The clearance of break shoe is too small	Increase the clearance of break shoe
4	The temperature of speed reducer is too high	Lacks lubrication oil or has too much lubrication oil	Pay attention to increase and reduce the oil properly
5	The temperature of the bearing of speed reducer is too high	Mainly has too much or too little grease lubricant; The quality of grease lubricant is not good; The clearance of bearing and axial direction does not conform to the requirements or the bearing surface is damaged.	Change the grease lubricant, readjust the clearance of bearing and change the bearing according to the stipulations
6	The speed reducer leaks oil	The driving fit of the abutted surface of joint part and the seal ring of axle head is worn	Change the seal ring
7	Cannot start the slewing mechanism	See whether it has foreign material blocked in the gear; the oil loadings of hydrodynamic clutch is too little	Clear foreign material; Oil properly
8	Jack too slowly	A. Oil pump is worn, and the efficiency slows down B. Oil mass is not enough or the oil filter is blocked C. Hand operated direction valve, valve rod and valve hole is worn seriously D. There is damage in piston of oil	Repair or change the damaged parts Add enough oil or wash oil filter; Examine or change valve; Change oil sealing

		cylinder and there have the phenomenon of inner discharge	
9	Has no strength to hoist or cannot jack	A. The inner discharge of the oil pump is serious; B. Overflow valve set up pressure; C. The valve core of hand operated direction valve is over worn; D. Overflow valve is block heavily	Repair or change the damaged parts, and adjust the pressure according to related speculations
10	Appear noise vibrating when the pressure of jack rises	Oil filter is blocked	Wash oil filter
11	The jacking system could not work	The sway of electric machine and oil pump is different	Change the rotating direction of electric machine
12	Appear quivering climbing when jacking	A. The air in oil cylinder piston is not emptied completely B. Guide mechanism has breakdown	Exhaust according to related speculations
13	The jack descends when it has load	A. There is breakdown in locking direction valve of cylinder head B. The seal ring of oil cylinder piston damaged	Clear the breakdown; Change the sealing element
14	Cannot start the luffing mechanism	1.Control the wire splice fault 2.Fuse is burned out 3.Machine winding alternated, it will appear short out, earth or circuit break 4.The voltage of electric machine is too low 5.Winding wire splice is wrong 6.Electromagnetic brake does not loose 7.The load is too heavy or the driving gear is breakdown	1.Check the wire splice drawing 2.Examine whether the fuse volume of fuse is too small, if it is small, change a big one 3.Measure the voltage of electric grid 4.Find the short out and circuit breaking part according to various speeds to repair them 5.Examine whether the break voltage and winding is circuit breaking or blocked
15	Luffing mechanism has unusual noise and the vibrating noise is too loud	1. Machine attrite 2. Worn between rotator and stator 3. Electric machine and speed reducer do not have the same center 4. The bearing lacks oil seriously or it is damaged 5. Gear box lacks oil 6. Gear is worn	1.Examine whether the clearance between rotator and stator is even or not 2.Examine whether the slip ring is worn and change it 3.Wash bearing and add new lubrication oil and change the bearing

		7. Two phase operation and has the sound of whistle	4.Change the gear 5.Cut off the power line and repair it
16	The temperature of luffing electric machine raises too high or smokes	1.The load is too big 2.Load lasts and the work is not conformed to the regulations 3.Two phase operation 4.Power line voltage is too low or too high 5.Electric machine winding earth or turn alternates and appear short out 6.The clearance of attrite is not correct 7.The break and release time is not correct 8.Ventilation of electric machine is blocked and the temperature is too high	1.Measure the stator current, if it is more than rated value, reduce the load 2.Operate according to the stipulations 3.Three phase current and clear the breakdown 4.Examine the input voltage and correct it 5.Find the cause and repair it 6.Adjust the clearance according to the requirements 7.Examine the voltage of break and delay the breaker running period, and clear the breakdown 8.Keep the ventilating shaft smooth
17	The bearing of amplitude mechanism is overheating	1.The bearing is burned out 2.Too much grease lubricant or too little grease lubricant	1.Change the bearing 2.Add lubrication oil according to the stipulations
18	Amplitude mechanism has electricity	1.Joint the power lead and earth connection wrongly 2.Do not connect the earth connection well 3.Connection line of electric machine scratches earth connection	1.Find out and correct it 2.The earth connection should be connected well 3.Find out and deal with it and correct it
19	Has no strength to hoist and the electric machine does not turn	1.Input voltage is too low 2.AC contactor line is broken	1.Examine the operation voltage to ensure the input voltage not lower than 360V 2.Place in circuit
20	The temperature of electric motor is too high	1.Main operation time is too frequent 2.Low speed using time is too long or do not open the hoisting brake	1.Reduce the operation time properly 2.Examine the hoisting brake

电气设备	第九章
9.1 工作机构	9-2
9.1.1 起升机构	9-2
9.1.2 回转机构	9-3
9.1.3 小车牵引机构	9-5
9.1.4 液压顶升机构	9-5
9.2 电气控制与操纵系统	9-8
9.2.1 起重机的电气操作	9-9
9.2.2 安全装置	9-10
9.2.3 安装注意事项	9-11
9.3 全变频电控系统介绍	9-11
Electrical equipment	Chapter 9
9.1 Working mechanism	9-2
9.1.1 Lifting mechanism	9-2
9.1.2 Slewing mechanism	9-3
9.1.3 Trolley traction mechanism	9-5
9.1.4 Hydraulic jacking mechanism	9-5
9.2 Electric control system	9-9
9.2.1 Electricity operation	9-9
9.2.2 Safety device	9-10
9.2.3 Attention during installation	9-11
9.3 All frequency conversion electric control system introduction	9-11

## 9.1 工作机构

起重机的工作机构包括：起升机构、回转机构、小车变幅机构及顶升机构，分别简介如下：

当总断路器已经合上，准备运行各机构前，必须先将左右操作手柄置于零位位置，然后按下起动按钮，总接触器吸合，联动台通电指示灯亮，塔机处于待令工作状态。作业前，司机首先发出几次声响信号，以提醒作业现场人员注意。操纵控制器时必须从零位开始，逐级推到所需要的档位。机构作反向运行时，操作手柄先回零位，然后再逐级逆向操作，禁止越档操作和急开急停。作业时可单独操纵一个机构，也可同时操纵几个机构，视需要而定。在司机下班或停止作业时，应按下急停按钮，切断控制回路电源。遇到紧急情况，可以立即切断司机室总断路器电源。

### 9.1.1 起升机构（见图 9-1）

起升机构对于不同的起吊重量有不同的速度，以充分满足施工要求。

注：本机构第一次使用一星期后减速器应立即换油并清洗。

本机构采用一台 YZP2-250M1-4B 30L 55kW 变频电机，通过圆柱齿轮减速机驱动卷筒。根据吊重可选择不同的滑轮倍率，当选用 2 倍率时，最大速度可达 92 米/分；若选用 4 倍率时，则速度可达 46 米/分。为达到起动和制动迅速又平稳，在减速机的另一侧还装有电力液压制动器，起升机构不工作时，制动机构应处在制动位置。在卷筒轴另一端有高度限位器，高度限位器可根据实际的需要进行调整。

## 9.1 Tower crane mechanisms

Crane working mechanism include: hoisting mechanism, slewing mechanism, trolley traction mechanism and hydraulic jacking mechanism, the details are described as follows:

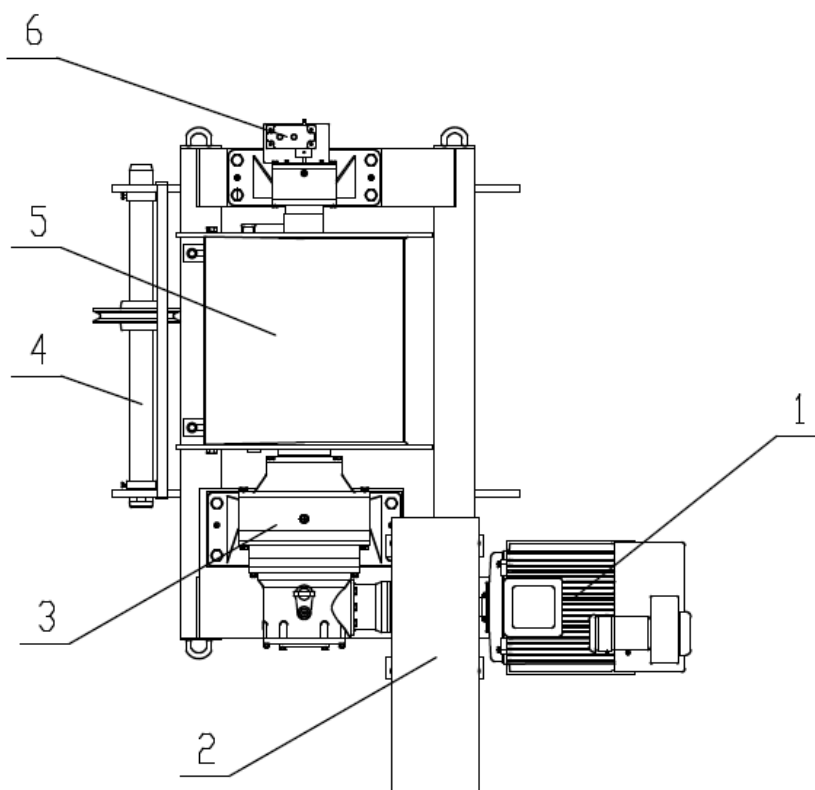
### 9.1.1 Lifting mechanism

To meet the construction requirements, the lifting mechanism functions in different speeds for different lifting loads.

Note: after the first week of employment, the speed reducer should be instantly cleaned and its oil should be replaced.

The lifting mechanism adopts with a variable-frequency motor of YZP2-250M1-4B 30L 55kW winding motor, driving drum through column gear reducer. It can choose different falls depending on different lifting weight. When at 2-fall, the speed will be 92 m/min, and

46 m/min. To achieve the rapid and stable operation of starting and braking, there is one electrical hydraulic brake. When the mechanism is out of service, the brake should be at braking. At the other side of drum, there is one height stopper which can be adjusted in accordance with actual needs.



1、变频起升电机 2、制动器 3、减速机 4、排绳装置 5、卷筒 6、高度限位器

图 10-1 起升机构

### 9.1.2 回转机构（见图 9-2）

回转机构共两套，对称布置在大齿轮两旁，均采用一台带风标制动器的 YTRVFW132M2-4F1 7.5kW 变频回转电机和一台不带风标制动器 YTRVFW132M2-4F2 7.5kW 变频回转电机驱动，经立式行星减速器端部的小齿轮与回转支承啮合，带动起重机上部的起重臂、平衡臂和塔顶等左右旋转，其最大速度为 0.8 转/分。电机带涡流和常闭式制动器，起重机起动和停车，平稳无冲击。

#### 回转制动

(1) 当回转停止后，就位状态时，因风力过大，就位困难，可按下风标制动按钮 SSF，KSB 接触器断电，制动器在弹簧作用下制动。再起动车回转时，自动解除制动。

(2) 停机后，回转机构应在自由状态下转动，可利用回转电机上的手动风标来接

除制动，使制动器保持在释放状态。

注：严禁塔机回转运行过程中打反车

回转支承采用 011.50.1600 型回转支承，大小齿轮传动比是： $i=151/16=9.44$ ，模数  $m=12$ 。

注意：安装回转支承时其滚道淬火软带（外部标记“S”或堵塞孔处）应放置在紧靠回转机构一侧。

### 9.1.2 Slewing mechanism (See Figure 9-2)

There are two mechanisms equipped at two sides of big gear, with an YTRVFW132M2-4F1(F2) 7.5kW inverter-fed motor. through the small gear at end of planetary reducer engaging with slewing bearing, drive around the upper part of tower crane: jib, counter jib and tower top. Its maximum speed is 0.8r/m. because of the eddy and constant-close brake, the start and stop of crane can be stable and firm.

#### Slewing braking

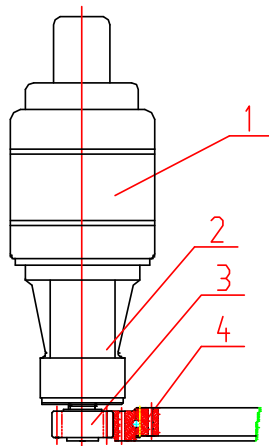
(1) When slewing stops, the tower crane is taking its position. But if the wind force is too strong to taking in place for tower crane, press the SSF button, and then contact KSB is powered off. Hence the brake acts under the function of spring. When you restart the slewing mechanism, the braking is automatically released.

(2) Stopped tower crane, the slewing mechanism is slewing at natural state. So you can take use of the manual weathercock on slewing motor to releasing brake, keeping it open to allow tower crane to slew freely.

Note: No reverse operation during the tower crane slewing.

Slewing bearing is 011.50.1600, and drive ratio of big and pinion is  $i=151/16=9.44$ , with modulus  $m=12$ .

Note: when mounting slewing bearing, its track quenching soft belt should be placed near to slewing mechanism side.



1—电动机 2—行星减速机 3—小齿轮 4—回转支承

图 9-2 回转机构

1 Slewing motor 2. Planetary reducer 3. Pinion 4. Slewing bearing

Fig 9-2 Slewing mechanism

### 9.1.3 小车牵引机构（见图 8-3）

小车牵引机构是载重小车变幅的驱动装置，变频电机（YTDVF132M1-4C 5.5kW）经由行星减速机（电机另一头装有电磁盘式制动器）带动卷筒，通过钢丝绳（7.7 6×19 1670 U ZS, GB/T8918-2008）使载重小车在 0—65 米/分的速度在臂架轨道上作变幅运行运动。牵引绳一端缠绕后固定在卷筒上，另一端则固定在载重小车上，变幅时靠绳一收一放来保证载重小车的正常工作。 的

### 9.1.3 Trolley traction mechanism (see Figure 8-3)

Traction mechanism drives trolley by an YTDVF132M1-4C 5.5kW motor. Through a planetary gear drum (at the end of motor is a electromagnetic disk brake), it drive trolley to move back and forth by rope (7.7 6×19 1670 U ZS, GB/T8918-2008) on jib track in the speed of 0-65 m/min. There are two traction ropes, one end of which are fixed to the two ends of traction drum respectively. The ropes, after winded, leads to the front and back of jib, through the jib root and its guide pulley, are fixed to trolley. Retract and release of ropes ensures the normal function of trolley when luffing.

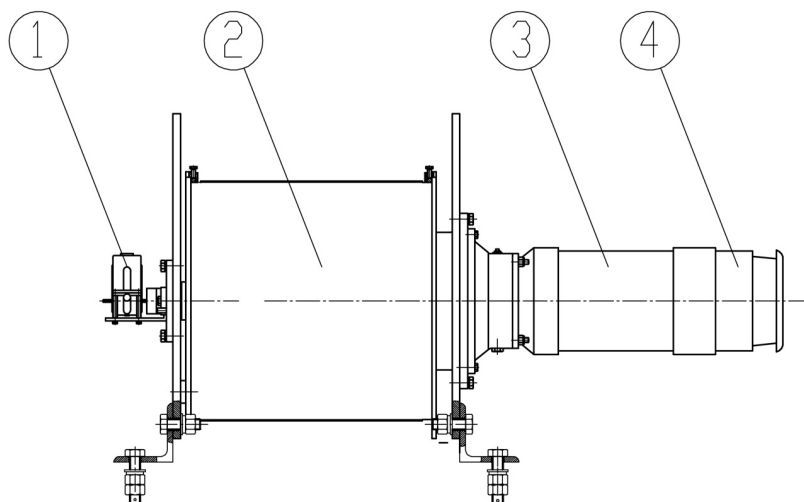


图 10-3 变幅机构

1. 变幅限位器    2. 卷筒（内置减速机）    3. 变幅电机    4. 制动器

9.1.4 液压顶升机构（见图 9-4）

9.1.4 Hydraulic jacking mechanism (Fig 9-4)

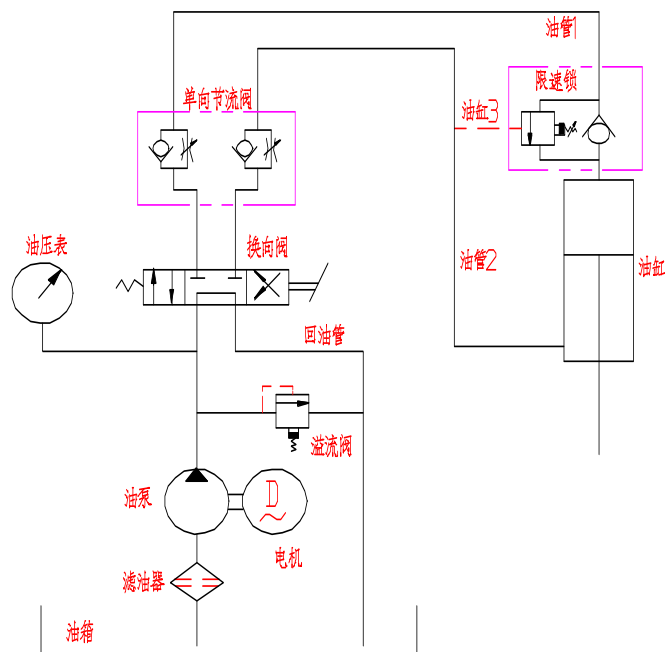


图 9-4 液压顶升机构原理图

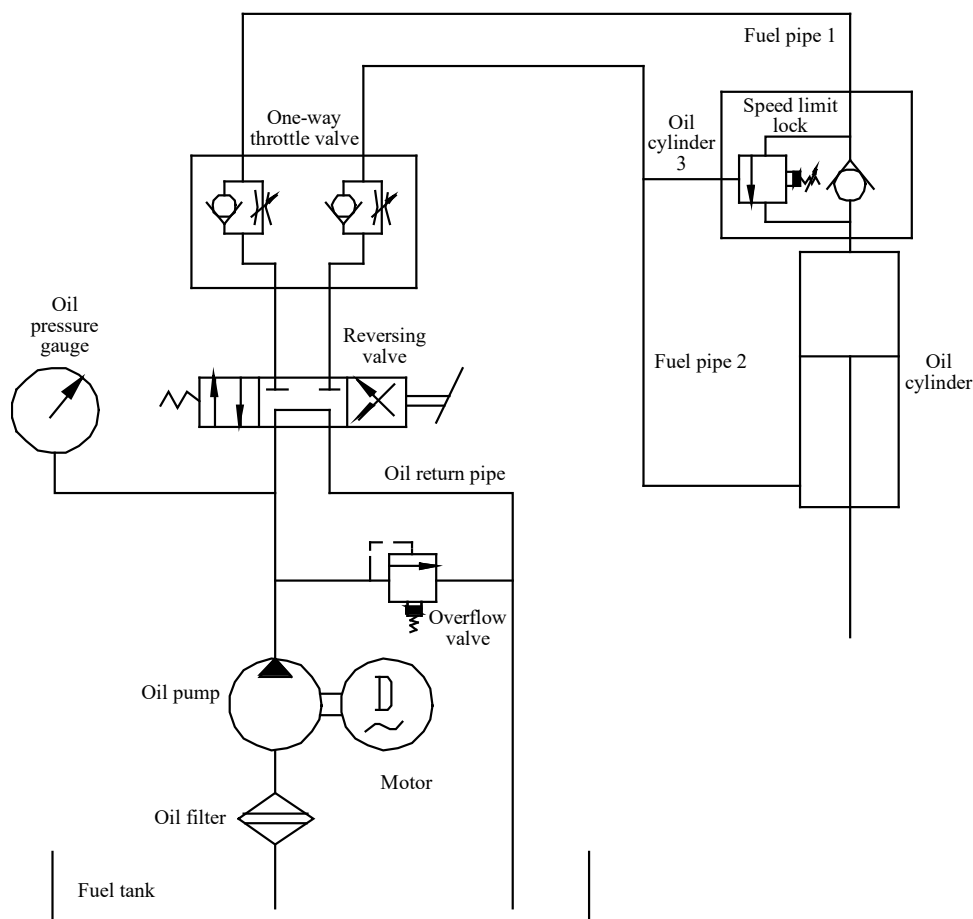


Fig 9-4 Hydraulic jacking mechanism diagram

液压顶升系统的工作，主要是靠安装在爬升架内侧的一套液压油缸和油压系统来完成。当需要顶升时，先由起重吊钩吊起一节标准节，放置在爬升架引进梁上。顶升梁顶在塔身就近的踏步上，把塔身标准节与下支座的 8 个连接销轴退出，开动液压系统，使活塞杆全部伸出，顶起上部结构，然后，操纵爬爪挂在标准节踏步上。油缸全部缩回，重新使顶升梁顶在塔身上另一踏步上，再次开动液压系统顶升，这样，三个工作循环可加一节标准节。

液压顶升过程的动力传递：当 Y160M-4V1 11KW 的电机开动时，带动高压油泵输出压力油（压力由负载决定，正常工作压力可达 36Mpa，流量约为 12.6L/min），油泵供出的高压油进入手动三位四通换向阀（中间装有一只压力表，便于观察油压读数），手动换向阀为的是控制油液的进油和回油方向的调整，手动换向阀的液压油经过液压锁输送到油缸中去，进行油缸的伸缩顶升工作。液压油缸的高压腔装有液压锁，可防止起重机在顶升过程中，因油路系统故障引起油管爆裂，而不至于负载下降，同时还可以防止负载下降速度过快。油泵出口的管路中装有溢流阀，以控制液压系统压力。

说明：请用户在使用前详细液压系统的《使用说明书》。

整个液压系统的主要性能参数如下：

顶升速度：  $V=(0.3\sim0.5)\text{m}/\text{min}$

工作流量：  $Q=12.6\text{L}/\text{min}$

安全溢流阀调定压力：  $P=38\text{MPa}$

顶升行程：  $H=1630\text{mm}$

顶升力：  $W=91\text{t}$

The function of hydraulic system depends on the oil cylinder set and oil pressure system. When lifting, hook up one mast and put it on introduction beam of climbing frame. The introduction beam, on the nearest tower step move the eight pin shafts connecting tower masts and lower support. Start hydraulic system to extend all pistons out to jack upper structure up. And then hang operating claw on mast step. Move all cylinders back and put introduction beam on another step and start hydraulic system again. Do this process three times to add one mast.

The power transmission in hydraulic jacking process: when motor Y160M-4V1 11KW starts, it drives high pressure pump to output pressure oil (pressure is decide by load, the normal working pressure can reach up to 38Mpa, with current of 12.6L/min) into manual directional valve of three-position-four-pass (in the middle is a pressure gage to observe oil pressure) which is used for controlling oil take-in and adjusting return direction. The hydraulic oil of manual directional valve is delivered to oil cylinder via hydraulic lock to achieve stretching and jacking of cylinder. Cylinder high-pressure cavity equips with hydraulic pressure lock to prevent oil pipe from exploding during jacking because of oil system breakdown. It also prevents dropping too fast with load. There is an overflow valve in oil pump export to control hydraulic system pressure.

Note: before using hydraulic system, the users should read the detailed Operation Instruction of Hydraulic Mechanism first.

Main parameters of system are following:

Jacking speed:  $V=(0.3\sim0.5)\text{m}/\text{min}$

Working current:  $Q=12.6\text{L}/\text{min}$

Rated pressure of overflow safety valve:  $P=38\text{MPa}$

Jacking distance:  $H=1630\text{mm}$

Jacking force:  $W=9\text{t}$

## 9.2 电气安装与使用

### 9.2.1 电控系统准备工作

#### 9.2.1.1 Preparation of electrical control system

##### 9.2.1.1.1 工地电源要求

电源要求为 380V, 50/60Hz。注：此处电源的电压要求是指塔机工作时的稳定电压为 380V。

##### 9.2.1.1 The power requirements

power requirements: 380V, 50/60Hz. Note: Here refers to the demands of power supply voltage stability voltage tower crane work is 380V.

##### 9.2.1.2 电气控制系统的组成

电气控制系统是整个塔机的控制中心，它包含以下设备：

- a) 左、右联动台；
- b) 驾配电箱、主控柜、行走柜（选配）；
- c) 起升机构、回转机构、变幅机构、行走机构（选配）；
- d) 重量限制器、力矩限制器、起升限位器、回转限位器、变幅限位器、行走限位器（选配）等保护装置

##### 9.2.1.2 Composition of electrical control system

The electrical control system is the control center of the tower crane ,it contains the following equipment::

- a) Left、Right console;
- b) Distribution cabinet、Main control cabinet、Traveling cabinet (optional);
- c) Hoisting mechanism、Slewing mechanism、Trolley mechanism、Traveling mechanism (optional);
- d) Weight limiter、Moment limiter、Hoisting stopper、Slewing stopper、Trolley limiter、Traveling stopper (optional) etc protector

##### 9.2.1.3 电气控制系统的连接

电控系统的连接示意图如下（具体详情请参照电气原理图-电气连接图部分）。

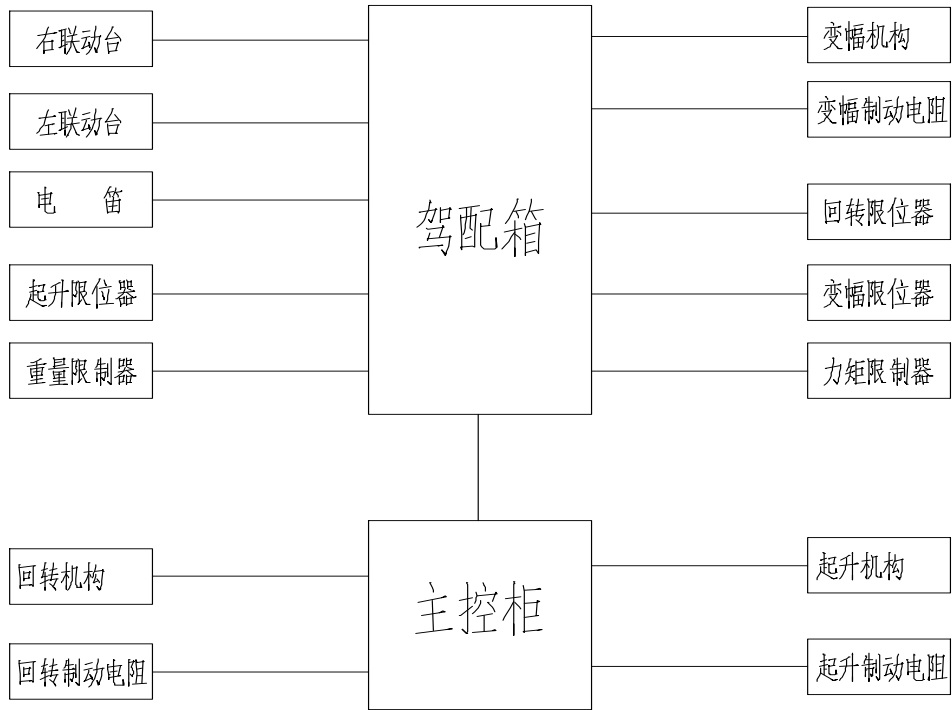


图 9.2-1 电控系统连接框图

### 9.2.1.3 Connection of electrical control system

The connection schematic diagram of the electrical control system is as follows (specific details please refer to electrical schematic- electrical connection schematic)

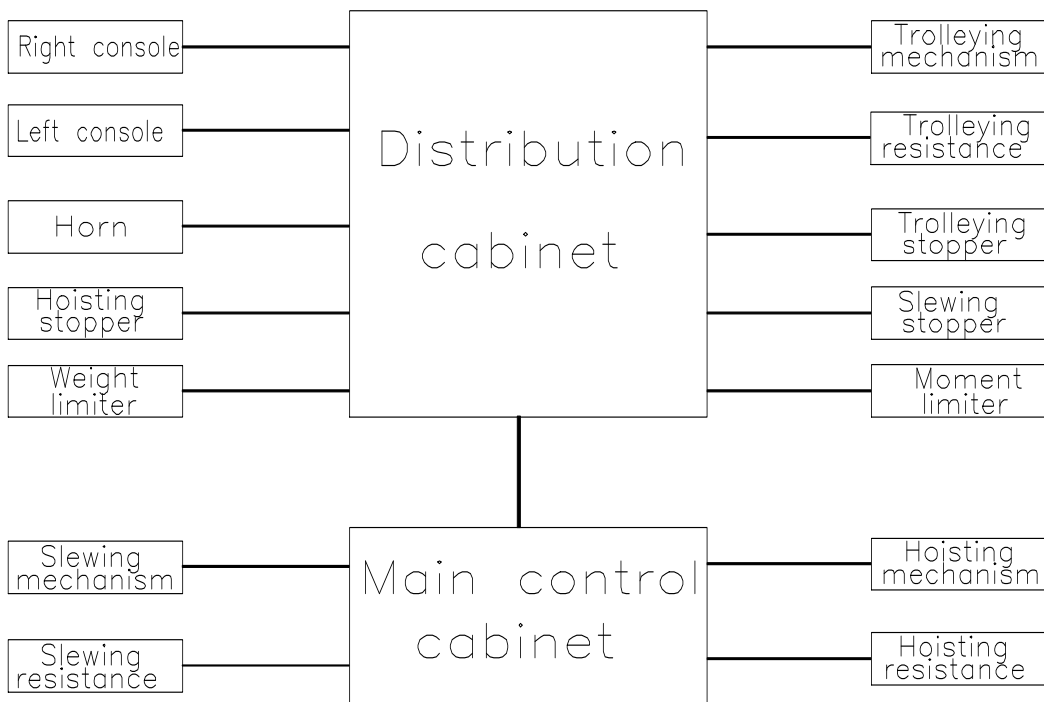


Fig 9.2-1 electrical connection schematic

### 9.2.2 电控系统使用方法

## 9.2.2 Using method of electrical control system

### 9.2.2.1 系统提示与报警信号

驾驶员在操作本电控系统时应熟悉系统提供的以下各种报警信号：

#### 9.2.2.1 System prompt and alarm signal

While operating the electrical control system the drive shall be acquainted with the following alarm signals provided by the system:

##### 1) 超力矩信号

当起重力矩超过最大允许值时，电控系统会作如下反应：

- a. 联动台上的红色“超力矩”报警灯闪烁。
- b. 联动台上的蜂鸣器发出连续的“嘀嘀嘀嘀”连续报警声。
- c. 主钩的上升运动被禁止。
- d. 小车的向外运动被禁止。

解除方法：向内变幅。

##### 1) Excessive torque signal

The electrical control system shall act as follows when the lifting moment exceeds the maximum allowable value:

- a. The red “excessive torque” warning light on the combination control console flashes.
- b. The buzzer in the control console utters successive “dick, dick, dick, dick” alarm sounds.
- c. The ascending movement of the main hook is prohibited.
- d. The outwards movement of the trolley is prohibited.

**Corrective action: The trolley shall travel inwards.**

##### 2) 超重量信号

当起重量超过最大允许值时，电控系统会作如下反应：

- a. 联动台上的红色“超重量”报警灯闪烁。
- b. 联动台上的蜂鸣器发出连续的“嘀嘀嘀”连续报警声。
- c. 主钩的上升运动被禁止。

解除方法：起升下降操作，减轻吊重。

##### 2) Overweight signal

The electrical control system shall act as follows when the lifting exceeds the maximum

allowable value:

- a. The red “overweight” warning light on the combination control console flashes.
- b. The buzzer in the control console utters successive “dick, dick, dick, dick” alarm sounds.
- c. The ascending movement of the main hook is prohibited.

**Corrective actions: Descend the hook and reduce the hoisting weight.**

### 3) 力矩预警信号

当起重力矩超过最大允许值的 90%时，电控系统会作如下反应：

- a. 联动台上的黄色“超力矩”预警灯闪烁。
- b. 联动台上的蜂鸣器发出连续的“嘀嘀”连续报警声。

向外变幅时没有高速，如正在以高速向外变幅时会自动减至最低速。

### 3) Pre-warning signal of torque

The electrical control system shall act as follows when the lifting moment exceeds 80% of the maximum allowable value:

- a. The yellow “excessive torque” warning light on the combination control console flashes.
- b. The buzzer in the combination control console utters successive “dick, dick ” alarm sounds.
- c. No high speed is attainable when the trolley travels outwards; the trolley traveling outwards at high speed will automatically decelerate to the lowest speed.

### 4) 超 75%重量换速信号

当起重量超过最大允许值的 70%时，电控系统会作如下反应：

- a. 联动台上的黄色“超重量”预警灯闪烁。
- b. 联动台上的蜂鸣器发出连续的“嘀”连续报警声。
- c. 升降操作时没有第四、五档，如正在以高速档升降运行中时，会自动减至第三

档速度。

**提示**

超 75%重量换速信号为起升变频控制系统才具有，而起升非变频控制系统不具有。

### 4) 75% Overweight throw-over signal

The electrical control system shall act as follows when the lifting load exceeds 70% of

the maximum allowable value:

- a. The yellow “overweight” warning light on the combination control console flashes.
- b. The buzzer in the control console utters successive “dick, ” alarm sounds.
- c. The fourth and fifth gears fail to function during the lifting operation, if a high-speed gear is applied for the lifting operation, the trolley shall automatically decelerate to the speed of the third gear.



**Lifting frequency conversion control system has 75% Overweight throw-over signal, and non lifting frequency conversion control system does not have.**

#### 5) 超 50%或 35%重量换速信号

当起重量超过最大允许值的 50%或 35%时，电控系统会作如下反应：

- a. 联动台上的黄色“超重量”预警灯闪烁。
- b. 升降操作时没有第五档，如正在以第五档升降运行中时，会自动减至第四档速度。

#### **提示**

起升变频控制系统具有超 35%重量换速信号，而不具有超 50%重量换速信号；起升非变频控制系统具有有超 50%重量换速信号，而不具有超 35%重量换速信号。

#### 5) 50% or 35% Overweight throw-over signal

The electrical control system shall act as follows when the lifting load exceeds 50% or 35% of the maximum allowable value:

- a. The yellow “overweight” warning light on the combination control console flashes.
- b. The fifth gear doesn't function during the lifting operation, If the fifth gear is used for the lifting operation, the trolley will automatically decelerate to the fourth gear.



**Lifting frequency conversion control system has 35% Overweight throw-over signal instead of 50% Overweight throw-over signal, non lifting frequency conversion control system has 50% Overweight throw-over signal instead of 35% Overweight throw-over signal.**

#### 6) 超高限位信号

当吊钩高度已达最大允许值时，电控系统会作如下反应：

- a. 吊钩的上升运动被禁止。

#### 6) **Ultra-high limit signal**

The electrical control system shall act as follows when the hook on the rise is several meters away from the ultra-high limit:

- a. The ascending movement of the hook is prohibited.

#### 7) **超高减速信号**

当吊钩高度距超高限位只有几米远时，电控系统会作如下反应：

- a. 吊钩上升运动自动减速至第一档速度。

#### 7) **Ultra-high reduction signal**

The electrical control system shall act as follows when the hook on the rise is several meters away from the ultra-high limit:

- a. The hook speed will automatically decelerate to the first gear while rising.

#### 8) **超低限位信号**

当吊钩下降高度已达最大允许值时，电控系统会作如下反应：

- a. 吊钩的下降运动被禁止。

#### 8) **Ultra-low limit signal**

The electrical control system shall act as follows when the hook height reduces to the maximum allowable value:

- a. The descending movement of the hook is prohibited.

#### 9) **超低减速信号**

当吊钩高度距超低限位只有几米远时，电控系统会作如下反应：

- a. 吊钩下降运动自动减速至第一档速度。

#### 9) **Ultra-low reduction signal**

The electrical control system shall act as follows when the hook height comes to several meters from the ultra-low limit:

- a. The hook speed will automatically decelerate to the first gear while rising.

#### 10) **变幅外限位信号**

当变幅小车运行到臂头时，电控系统会作如下反应：

- a. 变幅小车的向外运动被禁止，如正在向外变幅会突然停车。

#### 10) **Out-of-working radius limit signal**

The electrical control system shall act as follows when the trolley moves to the end of the jib:

- a. The outward movement of the trolley is prohibited; for example, the trolley traveling outwards will suddenly stop.

11) 变幅外减速信号

当变幅小车向外运行到距臂头只有几米远时，电控系统会作如下反应：

- a. 变幅小车的向外运动没有高速，如正在以高速向外变幅会自动减至最低速。

11) **Out-of-working radius reduction signal**

The electrical control system shall act as follows when the trolley travels outwards several meters from the jib end:

- a. No high speed is attainable when the trolley travels outwards; the trolley traveling outwards at high speed will automatically decelerate to the lowest speed.

12) 变幅内限位信号

当变幅小车已开至臂根部时，电控系统会作如下反应：

- a. 变幅小车的向内运动被禁止，如正在向内变幅会突然停车。

12) **Within-working radius limit signal**

The electrical control system shall act as follows when the trolley moves to the jib root:

- a. The inward movement of the trolley is prohibited; for example, the trolley traveling inwards will stop suddenly.

13) 变幅内减速信号

当变幅小车内行到距臂根部只有几米远时，电控系统会作如下反应：

- a. 变幅向内运动没有高速，如正在以高速向内变幅会自动减至最低速。

13) **Within-working radius reduction signal**

The electrical control system shall act as follows when the trolley moves inwards several meters from the root of the jib:

- a. There is no high speed when the trolley moves inwards; and trolley traveling at high speed will automatically decelerated to the lowest speed.

14) 回转左限位信号

当吊臂向左回转超过一圈半时，电控系统会作如下反应：

- a. 吊臂的向左回转运动被禁止，如正在向左回转则回转电机会自动失电。

**14) Left limit signal for slewing**

The electrical control system shall act as follows when the crane jib slews leftwards for over one and a half circle:

- a. The leftward slewing of the jib is prohibited; the slewing motor will automatically be de-energized if the jib continues slewing leftwards.

**15) 回转右限位信号**

当吊臂向右回转超过一圈半时，电控系统会作如下反应：

- a. 吊臂的右回转运动被禁止，如正在向右回转则回转电机会自动失电。

**15) Right limit signal for slewing**

The electrical control system shall act as follows when the crane jib slews rightwards for over one and a half circle;

- a. The rightward slewing movement of the jib is prohibited; the slewing motor will automatically be de-energized if the jib continues slewing rightwards.

**16) 向前行走减速停止限位信号**

当塔机向前行走距轨道尽头只有几米远时，会触发减速停止限位，电控系统会作如下反应：

塔机向前行走经几秒减速后停止。

**16) Forward-traveling reduction stop limit signal**

The electrical control system shall act as follows when the tower crane to travel forward at the end of the track from only a few meters away , will trigger the reduction stop limit:

After a few seconds when the tower crane traveling forward after reduction stop.

**17) 向前行走紧急停止限位信号**

当塔机向前行走距轨道尽头时，会触发紧急停止限位，电控系统会作如下反应：立即切断行走总电源，塔机立即停止向前行走。

**17) Forward-traveling emergency stop limit signal**

The electrical control system shall act as follows when the tower crane to travel forward at the end of the track , will trigger the emergency stop limit:

Immediately cut off the total power supply, the tower crane to immediately stop traveling forward .

18) 向后行走减速停止限位信号

当塔机向后行走走到距轨道尽头只有几米远时，会触发减速停止限位，电控系统会作如下反应：

塔机向后行走经几秒减速后停止。

18) **Backward-traveling reduction stop limit signal**

The electrical control system shall act as follows when the tower crane to travel backward at the end of the track from only a few meters away , will trigger the reduction stop limit:

After a few seconds when the tower crane traveling backward after reduction stop.

19) 向后行走紧急停止限位信号

当塔机向后行走走到距轨道尽头时，会触发紧急停止限位，电控系统会作如下反应：立即切断行走总电源，塔机立即停止向后行走。

19) **Backward-traveling emergency stop limit signal**

The electrical control system shall act as follows when the tower crane to travel backward at the end of the track , will trigger the emergency stop limit:

Immediately cut off the total power supply, the tower crane to immediately stop traveling backward .

20) 过欠压保护信号

当供电电压大于 110%额定电压或低于 85%额定电压时，电控系统会切断主电源，塔机停止工作。

- a. 如果长期过欠，请不要启动和工作以免损坏电机和电器件。
- b. 变频器上有过欠警告提示，变频器具有过欠压自动停机保护功能。

20) **Over/under voltage protection signal**

When the supply voltage is greater than 110% or lower than 85% of the rated voltage, electrical control system will cut off the main power supply , the tower crane to stop working .

- a. If long time over voltage or under voltage, please do not activate or operate the tower crane to avoid any damage to the motor and electrical appliances.
- b. Over/under voltage warning prompt is given on the frequency converter; the frequency converter is has the auto-stop protective function under over/under

voltage.

### 9.2.2.2 电控系统的操作

电控系统的操作步骤如下：

1) **准备工作：**包括刀开关操作、总断路器的操作、司机室电源断路器的操作、启动与急停按钮的操作。

2) **各机构的操作：**包括升降操作、回转操作、变幅操作、行走操作。

下面分别加以说明。

### 9.2.2.2 Operation of electrical control system

The electric system is operated in the following procedures:

1) Preparations: including operation of the knife switch, operation of the total circuit breaker, operation of the power circuit breaker in the cab, as well as the operation of start and emergency stop buttons.

2) Operation of each mechanism, including lifting、slewing、trolley and traveling.

See below for detailed descriptions.

#### 9.2.2.2.1 准备工作

##### 1) 刀开关的操作

刀开关装在塔身底部第一节标准节的刀开关箱内，作电源隔离用。将手柄往上推时刀开关闭合，三相五线制电源通过上行电缆送入塔上配电箱；将手柄往下拉时，刀开关断开，塔机上部失电。刀开关闭合后，配电箱箱上的电压表将指示输入线电压值。如果电压表无显示或电压不符合要求，则必须查清原因方能进一步操作。司机下班后，须断开刀开关。

注：标配产品没有配刀开关箱，若非标需求配有刀开关箱时，请按上述进行操作。

#### 9.2.2.2.1 Preparations

##### 1) operation of the knife switch

A knife switch arranged at the bottom of the first tower section , as the power supply isolation. The handle is pushed upwards the knife switch is closed, the three-phase five wire power cable into the tower through the upstream distribution box; the handle is pulled downward, knife switch, upper tower power loss knife switch closed. After the distribution box of the voltage meter will indicate the input line voltage. If the voltage meter display or voltage is required, you must find out the reason to further operation. The driver after work, must break operation switch.

Note: the standard product with no knife switch box, if the standard demand with knife switch box, please operate according to the above.

## 2) 总断路器的操作

只有在现场准备就绪，司机就位，需要作业时，才能合上总断路器。合开关前先应检查电压表的读数看是否正常。总断路器位于司机室内的配电箱上，其操作手柄暴露在箱门外，便于司机操作。塔机除司机室电源外所有机构、控制箱柜等的电源均由此断路

### 注意

当地面刀开关合闸后，即使总电源断路器处于断开状态，总电源断路器之前的线路也是有电的，请在操作、检修、维修、维护保养过程中注意安全，避免触电。

### 警告

执行总电源通电操作前，必须检查所有电气系统连接正常，否则会造成人员触电、电器件烧毁等危险事故。

### 警告

以下情况必须立即切断空气开关！

- a. 遇到危急情况而电控系统失灵时，（如接触器触头烧粘、联动台上急停按钮失灵时）。
- b. 司机下班或因事离开驾驶室时。

## 2) Operation of the total circuit breaker

The total circuit breaker can only be closed when all site preparations are ready and the driver is in position for operation. Before closing the switch, the readings indicated on the voltage meter has to be verified for compliance. The total circuit breaker is located on distribution box in the driver's cab. Its operation handle is exposed outside the box door for convenience of driver's operation. Except for cab power supply, the power supply of all mechanisms and the control cabinets of the tower crane are controlled by such circuit breaker.

### Caution

The knife switch is closed, even if the total circuit breaker is in off state, the driver's cab is also electric. Please pay attention to safety during operation, maintenance, repair avoid electric shock.

### Warning

Before the implementation of the total power supply operation, must check all the electrical system connection is normal, otherwise it will cause the person to get an electric shock, electrical parts burned and other dangerous accident.

### Warning

In case of the followings, the total circuit breaker shall be cut off immediately!

- a. Malfunction of the electrical control system under emergency conditions (for example, the contact of the contactor is burnt, or the emergency stop button on the control console fails).
- b. The driver leaves the cab after work or for any personal affairs.

### 3) 司机室电源断路器的操作

司机室电源断路器 QFE 位于驾配箱内，主要用作各种灯、风扇、用户取暖设备的短路保护。当操作司机室电源断路器合闸（将断路器的操作手柄往上扳）后，司机室电源供电回路得电（单相 220V）。此时可以通过司机室内的开关控制司机室内照明灯、风扇的开或关。当操作司机室电源断路器断开（将断路器的操作手柄往下扳）后，司机室电源断开。司机室电源断路器合上后不必每次下班时拉断。

#### 注意

将刀开关合闸后，即使电源总断路器处于断开状态，司机室电源供电回路也是有电的，请在操作、检修、维修、维护保养过程中注意安全，避免触电。

### 3) Operation of the power circuit breaker in the cab

The operation of the power circuit breaker QFE in the cab is located in the distribution cabinet. It is an automatic circuit breaker, which is mainly intended to provide short circuit protection for various lights, electric fan and the user's heating equipment. When the lighting circuit breaker is closed (by pulling up the hand lever of the breaker), the driver's cab power supply circuit will be energized (single phase 220V). The driver then may use the switches in the driver's cab to turn on or turn off the room light、electric fan. When the lighting circuit breaker is opened (by pulling down the hand lever of the breaker) , the driver's cab power supply circuit will be off. It is not necessary to open the lighting circuit breaker every time after work when it is closed.

#### Caution

**The knife switch is closed, even if the total circuit breaker is in off state,the driver's cab is also electric. Please pay attention to safety during operation、maintenance、repair avoid electric shock.**

### 4) 启动与急停按钮的操作

- a. **启动按钮**（绿色）位于右联动台面板上。它是一个双功能按钮，即：启动和电笛功能。总断路器闭合后，当旋转释放联动台急停按钮、并按下此按钮时，系统启动（主

回路的总接触器和控制回路的总接触器接通),左联动台上的绿色系统启动电源指示亮。当按下急停按钮时,系统停止,左联动台上的绿色系统启动电源指示灭。此外,当系统启动后,无论何时,只要按下启动按钮,就可以控制电笛鸣叫。

b. **急停按钮**(红色)也位于右联动台的面板上,为一红色自锁式蘑菇头按钮。与启动按钮相反,急停按钮的作用时切断主回路的总接触器和控制回路的总接触器,从而使各机构紧急停车。



当塔机运行遇到危急情况,来不及按正常程序停车时,或操作手柄失控时,必须立即按下急停按钮!而非紧急情况下,不得使用急停按钮作正常停车用。否则产生很大的冲击。

#### 4) Operation of start and emergency stop button

- a. **The start button** (green) is located on the panel of the right combination control console. It is a dual-purpose button for start and motor siren. Whenever the start button is pressed, the ringing of the motor siren can be controlled. In addition, the system can only be started by pressing this button when the main circuit breaker is closed (the general contactor of the main circuit is connected with that of the control circuit),The green power supply system on the left console lights. When pressing the emergency stop button, the system stops, the green power supply system on the left console lights out. In addition, when the system is started, no matter when ,as long as the start button is pressed, you can control the horn song.
- b. **The emergency stop button** is also located on the panel of the right combination control console, which is a red self-lock mushroom head button. Opposite to the start button, the emergency stop button is used to cut off the general contactor of both the main circuit and the control circuit, as to enable emergency stop of each mechanism.



**When the tower crane operation encountered a crisis situation, not according to the normal procedure of stopping, or operating handle out of control,must immediately press the emergency stop button! Non emergency cases, the emergency stop button should not be used for normal stopping, otherwise,it will have a great**

**impact.**

#### 5) 控制变压器输入侧电压等级调节的操作

为适应各施工现场塔机供电电源不稳定或存在差异的情况，电控系统中的控制回路变压器输入侧具有 365V、380V、400V、415V 不同的电压等级，一般出厂默认接入 380V 电压等级（非标设计除外）。如果工地主电源供电电压偏低（360V 左右）时，请将控制变压器输入侧的接入电压等级由 380V 调到 365V；如果工地主电源供电电压偏高（400V 左右）时，请将控制变压器输入侧的接入电压等级由 380V 调到 400V；如果工地主电源供电电压偏高（415V 左右）时，请将控制变压器输入侧的接入电压等级由 380V 调到 415V。

#### 5) Operation for controlling the voltage level of the input side of the transformer

In order to adapt to the construction site tower crane power supply is not stable or when there is difference, the input side control circuit transformer in electric control system with 365V、380V、400V、415V different voltage levels, general factory default access 380V voltage level (excluding non-standard design). If the power supply industry low voltage (about 360V), please access the input side of the transformer voltage level control from 380V to 365V; If the work power supply voltage is high (about 400V), please access the input side of the transformer voltage level control from 380V to 400V; If the work power supply voltage is high (about 415V), please access the input side of the transformer voltage level control from 380V to 415V;

#### 9.2.2.2.2 各机构的操作

当电控系统启动成功后，即可进行各机构的操作了。操作时使用联动台上的两只操作手柄和各种按钮。在使用操作手柄时，应先用食指和中指将手柄球头内的滑动块往上拉，解除零位自锁，方能推动自如。操作时请留意电控系统发生的声光报警信号。一般来说，当声光报警信号发生时，电控系统会自动作出相应的反应（如禁止某机构的运动，某方向运动减速等）。关于报警信号详见前面的“9.2.2.1 系统提示与报警信号”一节。

#### 9.2.2.2.2 Operation of each mechanism

Mechanisms can be operated when the electrical control system is successfully activated. The two operating handles and various buttons on the control console can be used during the operation. To use the operating handles, pull up the slide block in the ball of the handle to unlock the zero-position self-locking, and then the handle can be pushed freely. While

manipulating the handle, the buzzer in the control console will give a short sound of “tick” where a gear is reached. During the operation, the sound-light alarm signal generated by the electrical control system shall be noticed. Generally, when the sound-light alarm signal is produced, the electrical control system will automatically take corresponding actions (for example, prohibit the movement of a mechanism or decelerate the movement in a direction).For detailed alarm signal, refer to the previous section of “9.2.2.1 System prompt and alarm signal”.

### 1) 升降操作

升降操作通过右联动台上的手柄控制。上升时往里拉，下降时往外推。上升和下降各分五或三个档位，分别对应于五或三种速度。切换档位时必须逐级切换。

#### **提示**

在有些情况下，驾驶员需要将吊钩上升到某一位置时，但由于起升上升停止限位的缘故而不能实现，这时可以用左手按下按下左联动台上的“旁路”按钮，右手操作联动台上的起升上升手柄就可以将吊钩以一档的速度上升到位。

#### **注意**

起升旁路操作时，驾驶员要时刻保持高度注意谨防吊钩冲顶，在将吊钩上升到合适位置时，应及时将手柄打到零位位置，若发生紧急情况，请及时按下急停按钮。

### 1) Hoisting operation

Hoisting operation is controlled by pulling the handle on the right combination control console inward to ascend, and pushing forward to descend. Five or three gears are designed respectively for ascending and descending to indicate five or three speeds. Change the gear step by step.

#### **Caution**

In some cases,the driver will need to hook up to a certain position, but because of lifting-up stop limit account can not be achieved,then you can use the left hand to press the standby button ,the right hand to operate lifting-up the handle can be increased to a first speed up hook in place.

#### **Caution**

For lifting the standby operation,the driver should always maintain a high degree of attention to guard against the hook top,the hook is lifted to a proper position,should be in time to

operate the handle to zero position,if there is an emergency,please press the emergency stop button.

## 2) 变幅操作

变幅操作通过左联动台的手柄控制。向外变幅时将手柄竖直地往前推，向内变幅时将手柄竖直地往里拉。外变幅和内变幅各分三或两档。对应于从低到高三或两种速度。在进行操作时，无论是从低速至高速，还是从高速至低速都必须逐级切换。

### **提示**

在某些场合，驾驶员想让变幅小车开到臂根部，但由于变幅内限位的缘故而不能实现，这时可以用右手按下按下左联动台上的“旁路”按钮，左手操作联动台上的手柄就可以将变幅小车以一档的速度开到位。

### **注意**

在进行变幅旁路操作时，驾驶员要时刻保持高度注意谨防变幅小车撞到挡块，在将变幅开到合适位置时，应及时将手柄打到零位位置，若发生紧急情况，请及时按下急停按钮。

## 2) Trolley operation

Trolley operation is controlled by the handle on the left control console. For outward trolley, push the handle vertically forward, while for inward trolley, and pull the handle vertically inward. There are two or three gear positions respectively for outward and inward movement. Two or three gears are designed for both outward and inward trolley, corresponding to two or three speeds from low to high. During the operation, the gears shall be shifted step by step no matter it is from low to high, or from high to low.

### **Caution**

In some cases,the driver will need to move the trolley to the jib root, but because of within-working radius limit account can not be achieved,then you can use the right hand to press the standby button ,the left hand to operate the handle can be moved at a first speed trolley inward in place.

### **Caution**

For trolley the standby operation,the driver should always maintain a high degree of attention to guard against trolley hit the block,the trolley is moved to a proper position,should be in

time to operate the handle to zero position,if there is an emergency,please press the emergency stop button.

### 3) 回转操作

在进行回转操作前，将左联动台上的顶升/回转联锁选择开关选择到回转位置时，才允许进行回转操作，而禁止顶升操作。如果此选择开关在顶升位置时，允许进行顶升操作，而不允许进行回转操作。

回转操作通过左联动台的手柄进行控制。左回转时将手柄横着往左扳，右转时将手柄横着往右扳。左回转和右回转各分四档，对应于从低到高四种速度(RCV 为无极调速)。在进行操作时，无论是从低速至高速，还是从高速至低速都必须逐级切换。

当回转机构为常开式制动器时，即通电闭合刹车，断电打开刹车。在操作过程中，如需要回转停止，可以旋转左联动台上的回转制动开关至制动位置，使回转制动停止。建议除在特殊情况或紧急危险状态下，不允许在回转档位运行过程中操作回转制动开关，尤其是在回转高速运行中，因为起重臂在回转急停过程中具有大惯性冲击易造成危险事故。

当回转机构为常闭式制动器时，即通电打开刹车，断电闭合刹车。在操作过程中，如需要回转停止，可以按下左联动台上的回转制动风标按钮使回转制动停止。建议除在特殊情况或紧急危险状态下，不允许在回转档位运行过程中按回转制动风标按钮，尤其是在回转高速运行中，因为起重臂在回转急停过程中具有大惯性冲击易造成危险事故。

另外，若塔机回转配置有风标装置时，即当驾驶员下班时如遇大风天气则同时按下回转制动风标按钮和旁路按钮 5 秒以上开启风标装置，若联动台上的风标指示灯亮绿色，则表明风标释放成功，大臂能自由随风摆动，避免因天气原因导致大臂折断或塔机倒塔。

**▲ 注意** 回转和制动操作时应注意以下几点：

- a. 由于塔臂很长，惯性很大回转操作必须平稳。加速时手柄必须逐级地扳，减速时也必须逐步地退回。
- b. 除带有液力耦合器的回转机构外，严禁采用打反车的方法进行减速。
- c. 严禁在塔臂未停稳时使用制动开关或制动按钮。
- d. 当风速超过 6 级，严禁使用“制动”开关。
- e. 若系统的回转制动回路配有免维护蓄电池时，在外部电源停电或者突然断电情况下，如果“回转—制动”开关仍扳至“制动”位置，则回转盘式制动器仍然正常工作至少

一小时。

f. 若系统的回转制动回路配有免维护蓄电池时，驾驶员下班时必须将“回转—制动”开关仍扳至“回转”位置，以免蓄电池过度放电造成损坏。

**⚠ 注意** 在使用中，有时会出现以下现象：

- a. 回转启动困难，启动时间长。
- b. 回转停车时塔机晃动大。
- c. 工作一段时间后，回转电机发热严重。

此时，应首先检查供电电源，如在正常范围内，请通知本公司派员检修。

### 3) Slewing operation

**Before slewing operation, when the slewing and jacking interlock switch is selected to the slewing position, the slewing operation is allowed and the jacking operation is prohibited.**

**If when the slewing and jacking interlock switch is selected to the jacking position, the jacking operation is allowed and the slewing operation is prohibited.**

Slewing operation is controlled by the handle on the left combination control console. Left slewing is achieved by pulling the handle horizontally to the left, while right slewing by pulling the handle horizontally to the right. There are four gear positions respectively for left and right. Four gears are designed for both left and right, corresponding to four speeds from low to high. During the operation, the gears shall be shifted step by step no matter it is from low to high, or from high to low.

The slewing mechanism is normally-opened brake, that is, the brake is disabled through energizing and enabled through in case of power failure. In the operation process, if the slewing needs to stop, you can rotate slewing brake switch to the brake position, so that the slewing stops. Recommended except in exceptional circumstances or in the case of an emergency, it is not allowed to operate the slewing brake switch during the slewing rotation, especially in the high speed rotation. Because of the large jib in the process of slewing emergency stop has great inertia impact caused by dangerous accidents.

The slewing mechanism is normally-closed brake, that is, the brake is enabled through energizing and disabled through in case of power failure. In the operation process, if the slewing needs to stop, you can operate slewing brake weathercock button, so that the

slewing stops. Recommended except in exceptional circumstances or in the case of an emergency, it is not allowed to operate slewing brake weathercock button during the slewing rotation, especially in the high speed rotation. Because of the large jib in the process of slewing emergency stop has great inertia impact caused by dangerous accidents.

In addition, the tower crane is provided with the weathercock device, in case of heavy wind when the driver finishes work, At the same time, slewing brake weathercock button and standby button shall be pressed to open the weathercock device. If the weathercock indicator light on the console bright green, that was released successfully and the large jib can swing freely along with the wind, so that the large jib will not break off or the tower crane collapse due to the weather reasons.



**Slewing and slewing brake operation should pay attention to the following points:**

- a. Because the tower jib is very long, the inertia is very large, the slewing rotation operation must be smooth .Speed up the handle must be step by step, deceleration must be gradually returned.
- b. In addition to the slewing mechanism with a hydraulic coupler, is strictly prohibited to use the method of anti car to slow down.
- c. It is strictly prohibited to use the brake switch or the brake button when the tower jib is not stopped.
- d. when the wind speed exceeds 6, the use of "brake" switch is strictly prohibited.
- e. if the slewing braking circuit system with maintenance free battery, external power outage or in case of power failure, if the "slewing brake switch" is the plate to the "brake" position, then the slewing disc brake is still working for at least one hour.
- f. if the system is equipped with a rotary brake circuit maintenance free battery, the driver must turn the "turning - brake" switch to "turn" position, in order to avoid excessive discharge of the battery.



**During the application, sometimes the following phenomena will occur:**


- a. Slewing is difficult and takes long time.
- b. The tower crane swings heavily when slewing is stopped.
- c. The slewing motor produces great heat after working for some time.

Under such circumstance, the power supply shall be checked first, if the problem is within the normal range of maintenance, please notify our company to assign specialists for overhaul.

#### 4) 行走操作 (选配)


在操作行走前,请先将右联动台上的行走允许/禁止选择开关旋转到行走允许位置后,才能进行行走操作。在不需要进行行走操作时,请将此选择开关选择到行走禁止位置。

行走操作由右联动台上的手柄控制。将此手柄往左扳,大车前行,往右扳大车后行。手柄左右方向各分两档,对应于从低到高两种行走速度。启动时,应先从手柄中位扳到低速档,然后再扳到高速档;停止时,应先从高速档回到低速档,然后再回到停止档位。

 **注意** 除紧急情况外,严禁从高速档直接回到停止档位

#### 4) Traveling operation (optional)

Traveling operation is controlled by the handle on the right control console. Pulling the handle to the left, the cart travels forwards; while pulling the handle to the right, the cart travels backwards. The handle can activate two gears while being operated left or right, which corresponds to two traveling speeds from low to high. To start the cart, the handle shall be pulled from the middle gear to the low-speed gear, then to the high-speed gear, whereas to stop the cart, the handle shall be pulled from the high-speed gear to the low-speed gear, then back to the stop gear.

 **Caution** Unless emergency occurs, it is strictly prohibited to pull the handle directly from the high-speed gear to the stop gear.

#### 9.2.2.3 作业前检查

 **注意**

- a. 每次通电后,在进行作业前,操作者必须在空钩状态下首先检查各开关按钮(尤其是“急停按钮”)、操作手柄、制动器、行程限位及保护开关是否工作正常;
- b. 各限位保护开关是否调整好(具体调整方法参见主机使用说明书的相关章节);
- c. 各限位保护开关动作后,电控系统是否执行相应的保护功能(参见前述的内容);
- d. 如发现故障应立即停机检修。在故障或安全隐患未排除前,不得将塔机投入作业运行;
- e. 如遇潮湿天气,请在每次通电前检查电控柜及电阻柜,如有凝露现象,请勿开机工作,待水气蒸发或采用其他除湿措施后再使用,以免造成元器件的损坏。

#### 9.2.2.3 Inspection before operation

 **Caution**

- a. Each time after powering on and before operation, the operator must first inspect whether the switch buttons (especially the “emergency stop button”) under the empty-hook state, the operating handle, brake, range limiter and protection switch are operating normally;
- b. whether each limit protective switch is properly regulated (specific regulating methods shall refer to the relevant chapters in the operation manual);
- c. whether the electrical control system practices the corresponding protective functions when each limit protection switch acts (refer to the above-stated contents).
- d. In case of any failure, the machine shall be stopped immediately for inspection & overhaul; the tower crane shall not be put into operation unless the failures or safety potential risks are eliminated.
- e. In the event of moist weather, please check the electric control cabinet and resistance cabinet each time prior to powering on, if condensation problem is discovered, the crane shall not be started and shall only be used after the steam evaporates or other desiccant measures are taken to protect the elements from being damaged.

#### 9.2.2.4 检修与维护

电控系统应经常检修与维护，以排除故障，消除安全隐患，保证整机的正常运行，延长设备的使用寿命。应由具有相关从业资格的专业人员进行检修与维护工作，具体如下：

- a. 每天应对电控系统进行外观检查，防止触、漏电等事故发生。
- b. 经常检查所有电线、电缆有无损伤，如有损伤应及时用电胶布包扎或更换。
- c. 遇到电机有过热现象时要及时停车检查，排除故障后再继续运行，同时保证电机轴承润滑良好。
- d. 电机各部分电刷的接触应保持清洁，电刷接触面积不应小于 50%。
- e. 各电控箱、配电箱应经常保持清洁，在总电源切断情况下清除电气设备和电气元件上的灰尘。
- f. 各安全装置的行程开关的触点开闭必须灵敏可靠。
- g. 各电机及其它电气设备绝缘良好，其绝缘电阻应不小于  $0.5M\Omega$ 。
- h. 各电机、电控柜及其它电气设备的外壳接地端的接地电阻不得大于  $4\Omega$ 。
- i. 检查交流接触器是否有卡滞、吸合不良、触点烧坏等现象，若有请及时修复或更换。
- j. 检查接线是否有松动、发热、烧蚀等现象。



**警告**

若在检修中发现上述中的非正常现象，请及时紧固、修复、更换、调整。

#### 9.2.2.4 Overhaul and maintenance

The electrical control system shall be regularly overhauled and maintained to eliminate breakdowns and safety potential risks, as to ensure normal operation of the whole equipment and prolong its service life as well. Specialists with relevant occupational qualification shall undertake the overhaul and maintenance work. Specific as follows:

- a. every day to respond to the electrical control system for appearance inspection, to prevent electric shock and electric leakage and other accidents.
- b. often check all wire cable without damage, such as damage should be promptly with electric tape wrapped or replaced.
- c. when the motor has overheating phenomenon to be checked in time, troubleshooting, and then continue to run, while ensuring good lubrication of motor bearings.
- d. motor parts of the brush contact should be kept clean, brush contact area should not be less than 50%.
- e. all electric control box, distribution box should always keep clean, in the case of the total power cut off to remove the dust on electrical equipment and electrical components.
- f. the switch of the trip switch of the safety device must be sensitive and reliable.
- g. the motor and other electrical equipment insulation is good, the insulation resistance should be not less than 0.5M.
- h. motor, grounding resistance cabinet and other electrical equipment shell grounding terminal shall not be greater than 4 ohm.
- i. Check whether I. AC contactor card, pull side, burning of contact phenomenon, if timely repair or replacement.
- j. check wiring whether there is loose, heating, ablation and other phenomena.





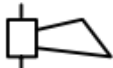


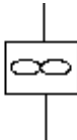
**Warning**





If the abnormal phenomenon in the maintenance of the above, please timely fastening, repair, replacement, adjustment.

### 9.2.3 电气图形符号

#### 9.2.3.1 附件类图形符号

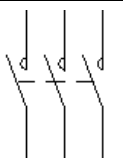

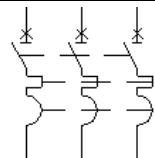
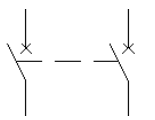



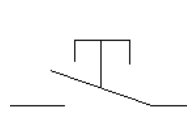




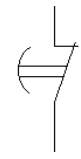
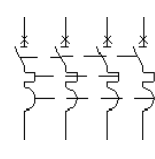
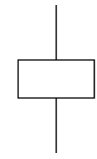
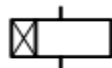

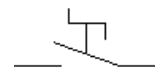

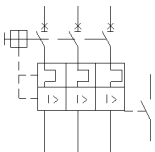
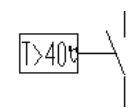
表 9.2-1 附件类图形符号

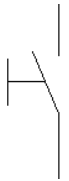
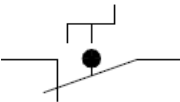
	蜂鸣器	Buzzer		电阻	Resistance
	电笛	Horn		加热器	Heater
	避雷器	Lightning arrester		轴流风机	Axial fan

	熔断器	Fusegear		照明灯或 指示灯	Light
	插座	Socket		电压表	Voltmeter

9.2.3.2 开关类图形符号







表 9.2-2 开关类图形符号

	接触器触点		急停按钮		三极断路器
	双极断路器		单极断路器		限位开关 常开触点
	限位开关常 闭触点		平头按钮		延时断开 的常开触 点
	常开触点		常闭触点		延时闭合 的常闭触 点
	延时断开的 常闭触点		四极断路器		继电器线 圈或接触 器
	通电延时继 电器线圈		断电延时继 电器线圈		转换开关 触点
	延时闭合的 常开触点		热断路器		温度开关

	照明灯或风扇开关		零位开关		
---	----------	---	------	--	--



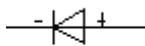
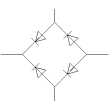
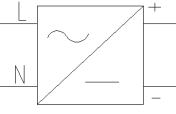
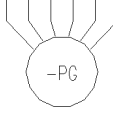
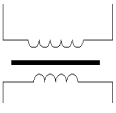
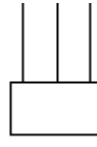
### 9.2.3.3 接线类图形符号

表 9.2-3 接线类图形符号

	地线		接线端		连接器插头
	参照插头		接线端子		连接器插座


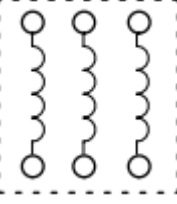
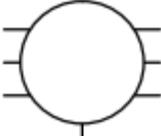

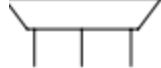

### 9.2.3.4 电子类图形符号

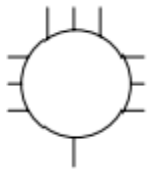
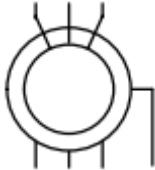
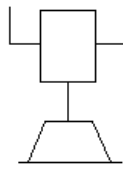
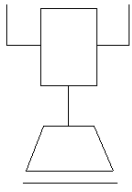
表 9.2-4 电子类图形符号

	温度传感器		电位计		整流器二极管
	单相整流桥		开关电源		编码器
	变压器		相序保护器		

### 9.2.3.5 电机类图形符号

表 9.2-5 电机类图形符号

	电磁线圈或直流电感线圈		三相电感线圈		双绕组电机
	单线圈电磁制动器		双线圈电磁制动器		单绕组电机

	三绕组电机		滑环式电机		闭式电磁制 动器
	开式电磁制 动器				

9.2.3.6 操作类图形符号

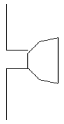


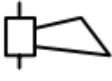


表 9.2-6 操作类图形符号


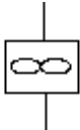


	起升上升		左回转		向外变幅
	起升下降		右回转		向内变幅
	向前行走		向后行走		

9.2.3 Electric diagram symbol

9.2.3.1 Graphical symbols for accessories

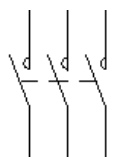

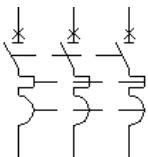
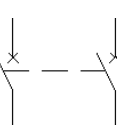



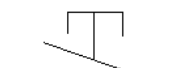



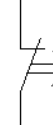
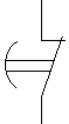
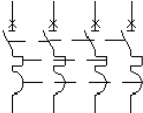
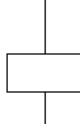
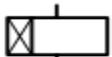


Table 9.2-1 Graphical symbols for accessories

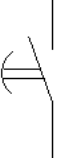
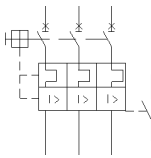
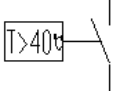
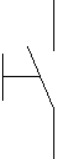
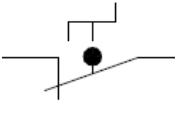
	Buzzer		Resistance		Voltmeter
	Horn		Heater		Socket

	Lightning arrester		Axial fan		
	Fuse gear		Light		

### 9.2.3.2 Graphical symbols for switch







Table 9.2-2 Graphical symbols for switch

	Contactor Main contact		Emergency Stop button		Three -pole circuit breaker
	Two- pole circuit breaker		Single- pole circuit breaker		Limit switch normally open contact
	Limit switch normally close contact		Flat butt		Delayed disconnection normally open contact
	Normally open contact		Normally close contact		Delayed closure normally close contact
	Delayed disconnection normally close contact		Four- pole circuit breaker		Relay or contactor coil
	Power delay relay coil		Power delay relay coil		Switch contact

	Delayed closure normally open contact		Thermal circuit breaker		Temperature switch
	Lighting lamp or fan switch		Zero position switch		



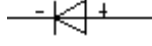
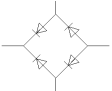
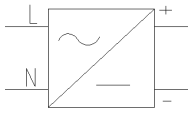
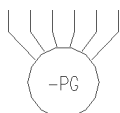
### 9.2.3.3 Graphical symbols for wiring connection

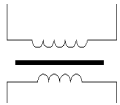
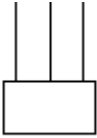
Table 9.2-3 Graphical symbols for wiring connection

	Earth wire		Connection point		Connector plug
	Reference arrow		Terminal		Connector Socket

### 9.2.3.4 Graphical symbols for electronic


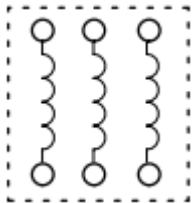
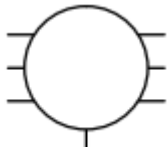

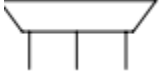

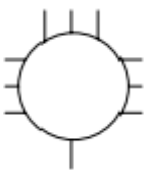
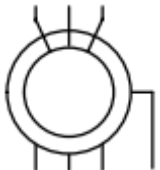
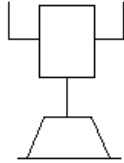
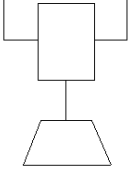
Table 9.2-4 Graphical symbols for electronic

	Temperature sensor		Potentiometer		Rectifier diode
	Single phase bridge rectifier		Switching Power Supply		Encoder

	Transformer		Phase sequence relay		
---	-------------	---	----------------------------	--	--









### 9.2.3.5 Graphical symbols for electric motor

Table 9.2-5 Graphical symbols for electric motor

	Electromagnetic coil		Three phase inductance coil		Double winding motor
	Single coil electromagnetic brake		Double coil electromagnetic brake		Single winding motor
	Three winding motor		Slip ring motor		Close type electromagnetic brake
	Open type electromagnetic brake				

### 9.2.3.6 Graphical symbols for operations

Table 9.2-6 Graphical symbols for operations

	Hoisting-up		Slewing- left		Trolley- out
	Hoisting-down		Slewing -right		Trolley- in
	Traveling forward		Traveling backward	x	

## 9.2.4 电气原理图

### 9.2.4.1 电气原理图文字符号说明

#### 9.2.4 Electrical schematic

##### 9.2.4.1 Electrical schematic symbol introduction

Table 9.2-7 Electric diagram symbol introduction

符号 Symbol	说明	Introduction	符号 Symbol	说明	Introduction
HINV	起升变频器	Hoisting Inverter	PLC	控制器	Controller
PGH	起升编码器	Hoisting Encoder	FLM	防雷模块	Lightning Protection Module
QFH	起升断路器	Hoisting Circuit Breaker	VC1/VC2	开关电源	Switching Power Supply
QFHF	起升风机断路器	Hoisting Fan Circuit Breaker	QF12/QF13/QF14/QF15/QFA	开关电源断路器	Switching Power Supply Circuit Breaker
RHB	起升制动电阻	Hoisting Brake Resistance	QFE	司机室断路器	Cab Circuit Breaker
KHB	制动器接触器	Brake Contactor	PV	电压表	Voltmeter
KAHU/KAHD/KAHL/KAHM/KAHB1/KAHB2/KAHA	起升中间继电器	Hoisting Auxiliary Relay	QF	总断路器	Main Breaker
SINV	回转变频器	Slewing Inverter	KMC	启动接触器	Starting Contactor

QFS	回转断路器	Slewing Circuit Breaker	KM	总接触器	Main Contactor
QFSF1/QFSF2	回转风机断路器	Slewing Fan Circuit Breaker	KAP	相序继电器	Phase Sequence Relay
QF30/QF31/QF32/QF33	回转变压器断路器	Slewing Transformer Circuit Breaker	SEM	急停按钮	Emergency Button
QFP	顶升泵站断路器	Jacking Circuit Breaker	HP	启动电源指示灯	Starting Power Indicator light
RSB	回转制动电阻	Slewing Brake Resistance	SSF	制动风标按钮	Brake Weathercock Button
KSB	回转制动接触器	Slewing Brake Contactor	SSJ	旁路按钮	Bypass Button
KPP	回转顶升连锁接触器	Slewing Jacking interlock Contactor	SST	启动按钮	Starting Button
KASL/KAR/KAS1/KAS2/KASB/KASF	回转中间继电器	Slewing Auxiliary Relay	SSP	回转顶升连锁按钮	Slewing & Jacking interlock control
SW	回转涡流控制器	Slewing Eddy Control	HML/HMA	力矩100%/80%指示	Moment 100%/80% Indicator
V30/V31/V40	续流二极管	Fly-wheel Diode	HLL/HL C	重量100%/50%指示	Weight 100%/50% Indicator
R30/R31/R40	电阻	Resistance	SZL	左联动台零位	Left Console Zero Position
V34/V35	整流二极管	Rectifier Diode	SZR	右联动台零位	Right Console Zero Position
QFF	风扇断路器	Fan Circuit Breaker	KA80/K A81/KA 82/KA8 3/ KA84/K A85/KA 86/KA8 7/ KA88/K	限位中间继电器	Limit Middle Relay

			A89		
QF10/QF11	控制变压器断路器	Control Transformer Circuit Breaker	KA90/KA91/KA92/KA93	限位中间继电器	Limit Middle Relay
VINV	变幅变频器	Luffing Inverter	SML1/SML2	100%力矩限制器开关	100% Moment Limiter Switch
QFV	变幅断路器	Luffing Circuit Breaker	SMA	80%力矩限制器开关	80% Moment Limiter Switch
RVB	变幅制动电阻	Luffing Brake Resistance	SFS	力矩防松开关	Moment anti-loose Switch
KAVI/KAVO/KAV1/KAV2/KAVB	变幅中间继电器	Luffing Middle Relay	SWL	100%重量限制开关	100% Weight Limit Switch
SVFL/FC/BL/BC	变幅限位开关	Luffing Limit Switch	SWH	70%重量限制开关	70% Weight Limit Switch
SSL	回转左限位开关	Slewing left Limit Switch	SWQ	35%重量限制开关	35% Weight Limit Switch
SSR	回转右限位开关	Slewing right Limit Switch	SHUL/SHUC/SHDL/SHDC	起升限位开关	Hoisting Limit Switch

## 塔机顶升

## 第十章

10.1 液压顶升装置	10-3
10.2 顶升数据	10-6
10.3 塔机的平衡	10-7
10.4 标准节的顶升与拆卸	10-7
10.5 塔机的附着及安装	10-21
10.6 附着塔机的拆卸	10-27

## Jacking and demounting of tower crane

## Chapter 10

10.1 Hydraulic jacking device	10-3
10.2 Jacking data	10-6
10.3 Tower crane balance	10-7
10.4 Mast jacking and dismantlement	10-7
10.5 Attached tower crane installation	10-21
10.6 Removal of attached tower crane	10-27



## 10.1 液压顶升装置

为确保液压顶升装置在塔机使用地正常运行以及正确的维护保养等处置，应遵循制造商/使用说明书对该装置的操作与启动的说明。

### 10.1.1 液压顶升装置组装

液压顶升装置的组装应按照制造商签发的图纸和使用说明书进行。安装时，高压油管应坚固可靠，以防止震动和移位；高压软管应充分考虑其弯曲半径和足够张弛的余地；特别注意应对高压油管（热弯管或焊接管）、高压软管的内管进行清理作业。

10.1.1.1 在组装时，对电机、油泵、油缸和各种阀件等部件的机械找正、定位，应按照使用说明书的规定进行。任何不均匀/不规则的紧固都可能出现变形。

10.1.1.2 液压顶升装置的电机、油泵和阀件应安装在油箱热辐射以及冷却空气不受限制的位置。

10.1.1.3 液压顶升装置所使用的电源的电压和功率应满足该装置的使用要求。在参照本使用说明书同时，应参照生产厂家的使用说明书。

### 10.1 Hydraulic jacking device

To guarantee the normal operation and correct maintenance of hydraulic jacking device, you should do strictly according to the instruction of the device.

#### 10.1.1 Assembling of hydraulic jacking device

Complete the assembling process according to the instruction. In assembling, the high-pressure oil pipe should be fastened in case of replacement and shaking, besides, it shall meet the requirement for bending radius and stretching condition. Pay special attention to clean the inner pipe of high-pressure oil pipe and soft pipe.

10.1.1.1 In assembling, get the right direction and position of motor, oil pump, oil cylinder and the valves, depending on the instruction, because any nonuniform or irregular fastening would result at deformation.

10.1.1.2 The motor, oil pump and valves of hydraulic jacking device should be installed where the heat radiation and cooling air of oil tank are not limited.

10.1.1.3 The power supply voltage and power should meet the requirements of the device, as required in instruction.

## 10.1.2 启动操作

在对油箱注油之前，应对油箱内部、过滤器以及油管进行清理检查。油箱的顶盖和过滤器的密封锁扣应良好。对带有空气干燥过滤器的装置，应特别注意安装质量与精度。

### 10.1.2.1 油箱注油

液压项升装置油箱使用的油品规格应按照使用说明书给出的规格选用（相关的油品在过滤器管座上亦有标注）。油箱注油可用注油机注油，亦可手工注油，但任何注油方式，都必须在进油口上加上滤油网，以防杂物进入。在注油时，由于箱内含有空气等其他因素，油箱的油位会缓慢下降，应关注液位必须至标志位置。

### 10.1.2.2 压力油箱

对于借助氮气作为装置必要压力的压力油箱操作，必须严格按照制造商的技术规程执行作业。

### 10.1.2.3 油泵轴的旋转方向

检查油泵轴实际旋转方向与装置上标注的旋转方向相一致这很重要。具体的检查操作可释放电机与油泵的联轴器后进行。如联轴器是可拆卸，油泵在注满油液后作无载运转以确定旋转方向。此时电机的操纵应采用点动方式，以防油泵的意外损伤。

## 10.1.2 Starting

Clean and check the oil cylinder, filter and oil pipe before filling oil. Both cover of cylinder and sealing lock of filter needs to be good. Pay attention to its installing quality and accuracy for devices with air filter.

### 10.1.2.1 Filling oil

Choose oil for jacking cylinder as required on Instruction. Filling oil methods are filling mechanically or manually, which both needs filter net to prevent foreign things into. When filling oil, make sure the oil level reaching up to mark position, since oil level will descend slowly because there may be air or something else in cylinder.

### 10.1.2.2 Pressure oil tank

The pressure oil, taking nitrogen as necessary pressure, should be operated strictly in accordance with the technical process by manufacturer.

### 10.1.2.3 Oil pump axis rotation direction

It is important to check whether oil pump actual rotation direction is same with the

marked direction on device. The detailed inspection can be done after releasing coupler of motor and pump. If the coupler is removable, confirm the rotation direction through no-load running after fully filled. In this case, motor shall be operated as point-moving in order not to damage oil pump.

#### 10.1.2.4 启动操作、压力释放

由于油泵的结构不相同，试机时，应关注制造商针对液压顶升装置的具体说明书（多数油泵是无载启动，但有些输油泵须带载启动）。该说明书是指导电机、油泵的特殊启动程序的依据（可了解油泵结构形式、吸油的高度以及吸油的摩擦损耗）。

电机启动之前，应检查确认吸入管道油路上所有的阀是打开的。电机操纵按点动方式，确认油泵的吸油功能。

对采用特殊压力的压力油箱，应选有特殊压力的进给压力油泵。此类油泵在使用时必须释放空气。释放可借助于排气口进行。排气的结果是使油箱内的油液无气泡为止。压力阀和油泵应按低压进行调节。

规格较小的液压顶升装置。压力释放是由顶升油缸完成的。即：顶升油缸以全行程工作 1—2 次，在油缸活塞杆往返运行到极限时，应暂时停在油缸顶部 2-3 秒。在此操作完毕后，油箱的液位应补充到标志的位置。

#### 10.1.2.4 Starting operation and pressure releasing

Do commissioning as the instruction (for motor and oil pump with special starting process and for knowing about pump structure, oil-inhaling height and friction waste) because the structure of oil pump varies from different type (some are starting-without-load, while some are with-load type).

Before starting motor, guarantee that all valves on input oil pipe are open. The motor is operated as point-moving. Check the oil absorbing function of oil pump.

The special-pressure oil tank should equip with special pressure oil pump. The air in pump shall be released when using pump to contributing air exhausting, until there is no air at all. Adjust pressure valve and oil pump as low pressure.

For small-specification hydraulic jacking device, its pressure releasing is completed by oil cylinder, i.e. jacking cylinder works at whole stoke 1 to 2 times. When piston rod of oil cylinder runs to and fro, stop at cylinder top at least 2 to 3 seconds. After this, oil in cylinder shall be refilled to mark position.



油箱内应留有足够的容积空间。

#### 10.1.2.5 功能测试

- 1) 在功能测试之前，所有的阀(如：流量控制阀、节流阀、载荷自锁阀、分配阀等)应关闭。
- 2) 压力控制阀(溢流阀)在较小压力时仍可调节。
- 3) 操纵单向控制阀的手柄，监视压力表，缓缓控制压力控制阀升高至理想工作压力区。流量控制阀固定在适当的压力数值上。



Sufficient space in oil cylinder is needed.

#### 10.1.2.5 Function test

- 1) Before test, all valves should be close, such as current valve, throttle valve, load self-lock valve.
- 2) Pressure control valve (relief valve) is still adjustable in the lower pressure.
- 3) Manipulate one-way valve control handle and monitor pressure gauges. Control pressure valve slowly rises to the desired working pressure area. The flow control valve is fixed to the appropriate pressure value.



- 4) 压力调节时，不得超过最大值。

#### 10.1.2.6 压力调节的警示

在操纵压力控制阀进行压力调节时，调节压力仅能到达规定的工作压力为止，不得超出规定的最大压力值。为避免过大的功率消耗和油液的过热，可适当降低些工作压力。确认的最大压力值一般在压力控制阀或其他阀件上标注。



**The pressure when regulated shall not exceed the maximum.**

#### 10.1.2.6 Warning of pressure regulator

When regulating pressure by pressure control valve, pressure can only reach up to the specified operating pressure and shall not exceed the specified maximum value. In order to avoid excessive power consumption and overheating of the oil, it may be

appropriate to reduce work pressure. The maximum pressure value is generally recognized on the pressure mark of control valve or other valve.



**安全阀与压力控制装置已封，未经许可不得进行压力调节。**

- 1) 功能测试结束后，可用电磁阀(有配置的)进行电控操作。
- 2) 操作之前，应检查油箱的液位。必要时应补充油。
- 3) 油箱工作温度为 50°C，最大不得超过 70°C。
- 4) 液压顶升装置工作一段时间后，(约 10 小时)，应清洗或更换滤芯。
- 5) 压顶升装置的功能使用寿命取决于油品的质量（即：纯度）。为此应按使用说明规定的油品的选用。
- 6) 在按使用说明书的规定进行短期正常的运行之后，应检查电机、油液、轴承的工作温度正常与否。



**Safety valve and pressure control device is sealed, and pressure regulating without permission is prohibited.**

- 1) After function test, do electrical control by solenoid valves (configured).
- 2) Before the operation, check the tank level. Add oil if necessary.
- 3) The oil tank temperature is 50 °C, and the maximum may not exceed 70 °C.
- 4) After the hydraulic jacking system working for some time (about 10 hours), you should clean or replace the filter.
- 5) The pressure lifting device function life depends on the quality of the oil (ie: purity). So use specified oil as required.
- 6) After short-term normal operation in accordance with the provisions of the manual, you should check the operating temperature of motor oil, bearing is normal or not.

### 10.1.3 维修

液压顶升装置早维修之前，应遵循下列规定：

- 1) 在打开/取出阀件、油管时，应先释放系统压力（具体操作见 9.1.2.1 章节）。同时系统装置应采取安全防护措施（如：用支撑加固等）；
- 2) 油箱应该放空；
- 3) 在打开液压顶升装置时，周围的环境应保持清洁，以防止污染；

- 4) 维修期间，应采取必要的措施，以防非有关人员启动系统装置，（如：关闭主开关、关闭电源）。
- 5) 准备适当的金属盘：



上述 1) —5) 条未落实，不得打开系统装置！

- 6) 系统装置打开后，应做好防污染措施。维修时周围应保持良好的清洁度；
- 7) 系统装置维修完成后，应按 10.1.2 章节启动操作，并检查功能。

### 10.1.3 Maintenance

Before the early repair of hydraulic jacking equipment, you should follow the following rules:

- 1) When opening or removing valves, tubing, you should release the system pressure, besides take safety precautions for the system. (eg: with support reinforcement);
- 2) The tank should be vented;
- 3) When you open the hydraulic jacking system, the surroundings should be kept clean to prevent contamination;
- 4) During the maintenance period you should take the necessary measures to prevent irrelevant personnel to start the system devices (such as: turn off the main switch or the power supply).
- 5) Prepare appropriate metal plate:



**The system device can not open if above 1) to 5) are not implemented!**

- 6) After the system unit is opened, you should be prepared to anti-pollution measures. Cleanliness should be maintained well;
- 7) After the system device repair is completed, you should check the system performance.

### 10.1.4 维护保养

液压顶升装置所有可拆卸的部件均处在稳定的油液中，故无须作太多的维护保养。系统装置的重点维护保养是电机轴承的润滑。其他方面的维护保养应遵循下列规定：

- 1) 液压顶升装置首次运行 40 — 50 小时后，应检查油箱的油量，清洗或更换过滤

- 器滤芯，检查所有油路管道的接头。
- 2) 液压顶升装置运行 2—3 月后，应检查油液的质量(即：纯度)。具体可根据油液的污染程度或油液的工作时间来决定换油的概率。
  - 3) 液压顶升装置运行 1000 — 1200 小时后，应换一次油。在换油时，应对油箱内部剩余的油液进行冲洗清除处理。同时在换油时，应检查过滤器，必要时作更换处理。(在装有空气干燥过滤器的装置，应检查干燥剂的颗粒，必要时作更换处理)。
  - 4) 油箱中的油液位应定期检查。对油液消耗过多，应找出原因，排除故障。日常损耗的油液应及时补充至标志油位。污染的油液必须马上更换。
  - 5) 应经常检查油路管道的泄漏情况。对于松动的部件或连接件应检查、紧固，对于损坏的部件应及时更换。
  - 6) 液压顶升装置中的所有的电机、油泵、阀件应按规定的工作压力和工作温度进行检查、校正，以保持正常的运行。
  - 7) 对于液压顶升装置的工作性能和工作状况应经常检查。特别是压力控制阀，应检查其调整压力是否符合工作压力。

#### 10.1.4 Maintenance

All removable parts hydraulic jacking system is in stable oil, and there is no need for too much maintenance. Focus system maintenance on the motor bearing lubrication. Maintenance of other parties should follow the following rules:

- 1) After the first time of running 40 to 50 hours of hydraulic lifting device, you should check the oil tank, clean or replace the filter element, and check all oil pipeline joints.
- 2) After running hydraulic jacking system 2 to 3 months, you should check the quality of oil (ie: purity). Specifically, determine the probability of oil change according to the degree of pollution or working time of oil.
- 3) After running hydraulic jacking system about 1000 to 1200 hours, the oil should be changed once. When changing oil, clean the remaining oil inside the tank. If necessary, replace it. (The device which is equipped with air-dry filter should be checked desiccant granules and if necessary, replace it.
- 4) The oil level in tank should be checked regularly. For excessive oil consumption, you should find out the reason and troubleshoot it. Daily consumption of oil should be added to the oil level mark. Contaminated fluid must be replaced immediately.

5) You should check for leaks oil pipeline often. For loose parts or connections, you should check and fasten them. For damaged parts, replace them.

6) All motors, pumps, valves of hydraulic jacking system are required to be checked to work under pressure and temperature, in order to maintain normal operation.

7) Work performance and working conditions for hydraulic jacking device should be inspected regularly. In particular, the pressure control valve should be checked for its adjustment pressure is in compliance with the working pressure.

#### 10.1.5 定期维护保养

液压顶升装置运行一定时间之后，所有液压件应进行维护保养。根据系统装置的类型和使用地的工作条件，定期维护保养应按使用说明书的要求在 5 年之内进行一次。维护保养时，应对管道气体、油液质量（特别是受污染的）以及油泵、油箱、阀、磁性过滤器等进行检查、维护保养。维护保养时应保持周围环境的清洁度，以防止污染。损坏/磨损的密封件或部件应及时更换。

10.1.5.1 油路管道的紧固件应检查、紧固或更换。

10.1.5.2 定期维护保养的最佳决策是采用更换处理。届时可将旧件送交制造商进行维修。同时用户应作好更换的记录，并制定定期维护保养的时间表。



**再次注意：打开液压顶升装置时，应保持良好的清洁度。**

#### 10.1.5 Regular maintenance

After running the hydraulic jacking system a certain time, all hydraulic parts should be maintenance. Depending on the type and working conditions of the system, regular maintenance should be carried out once as the specification requirements within five years. In maintenance, check and maintain pipeline gas, oil quality (especially contaminated) as well as pumps, tanks, valves, filters, and other magnetic filters, keeping the cleanliness of the environment to prevent contamination. Damaged or worn seals or parts should be replaced.

10.1.5.1. Fasteners of oil pipeline should be checked, tightened or replaced.

10.1.5.2. The best regular maintenance is to take replacement treatment. Old pieces can be sent to the manufacturer for repair. Meanwhile users should be ready to do the record, and to develop a regular maintenance schedule.



**Caution** When Opening hydraulic jacking system, you should maintain good cleanliness.

## 10.2 顶升数据

塔机顶升期间允许的风速

风平行于起重臂=16 米 / 秒(相当于 58 公里 / 小时=风力 7 级)

风垂直于起重臂=14 米 / 秒(相当于 50 公里 / 小时=风力 6 级)

## 10.2 Jacking data

In jacking tower crane, the allowable wind speed

The wind is parallel to jib =16m/s (equivalently 58km /h=7 level of wind force)

The wind is vertical to jib =14m/s (equivalently 50km /h=6 level of wind force)

## 10.3 塔机的平衡

### 10.3 Tower crane balance

	起重臂长度 m Jib length:	35.0	40.0	45.0	50.0	55.0	60.0	65.0	70.0
吊钩配重 Hook counterweigh	塔身节 Tower mast	1764Kg	1764Kg	1764Kg	1764Kg	1764Kg	1764Kg	1764Kg	1764Kg
变幅小车 距离 Trolley distance D(m)	带塔身节的 变幅小车 Trolley with tower mast	22.1	37.1	36	33.6	30.8	25.1	25.1	16

## 10.4 标准节的顶升与拆卸

塔机工作高度的变化是通过安装在塔身上标准节数量的变化来实现的。在塔身上增加标准节和减少标准节是利用塔机套架和液压系统来完成的。在塔机上增加标准节称为顶升，在塔机上减少标准节称为落塔或落节。本章节详细介绍顶升和落节的过程和注意事项。

### 10.4.1 标准节的组装

由于塔身标准节主弦杆的规格有二种，因此，在安装标准节时，应根据标准节的类型，依次从下到上安装塔身标准节。从下到上塔身组成为：1 节基础节，17 节标准节，严禁次序混乱。

### 10.4 Jacking and dismounting mast

The change of working height of tower crane is realized from the change of mast quantity on tower crane. The increasing and decreasing of masts is completed by operation of tower telescopic frame and hydraulic system. This chapter is mainly about the jacking and decreasing procedures and announcements.

#### 10.4.1 Assembly mast

The main chord of tower mast are two kinds, so when installing masts, you need to mount tower mast from bottom to top according to the mast type. The tower masts from bottom to top are: one base section, seventeen masts. The order is very important, so please don't confused,

塔机标准节为片式结构。出厂包装状态为分组片式包装，每组包括 A、B、C、D 各一片。在使用前要将四片用专用螺栓联接成一整体。

标准节装配要点：

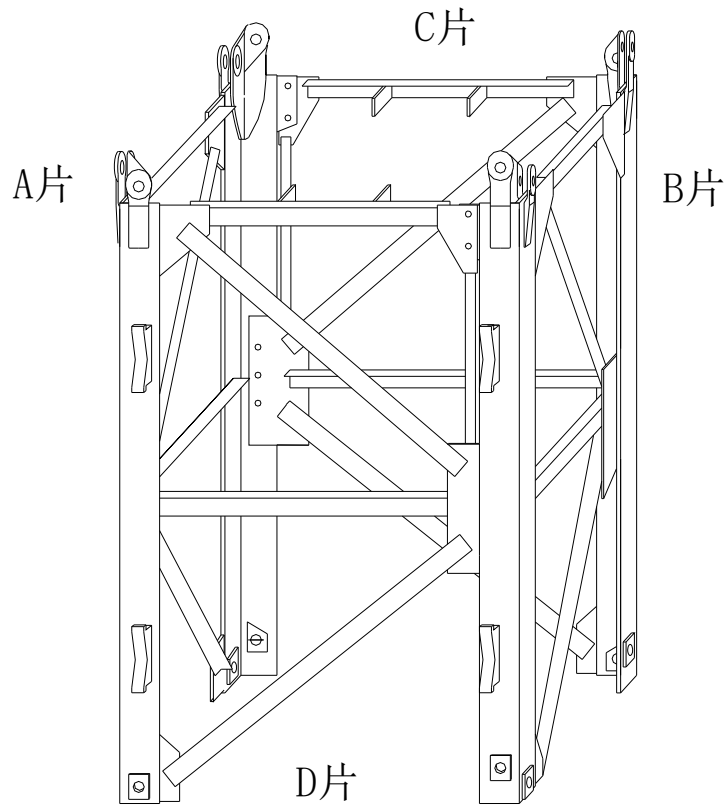
- 1、带顶升踏步的两片（D 片和 B 片）相联接。
- 2、带爬梯固定板的两片（D 片和 C 片）必须面对面装配（见图 9-1）。
- 3、整个标准节共用 20 个专用螺栓装配在一起。装配时螺栓帽在外，螺母在内，不得装反。
- 4、螺栓预紧力矩  $1240\text{Nm}\pm 20\%$ 。
- 5、每一片的联接板要装在角钢的里面。

#### Assembling of mast

Tower crane masts are split-type, and during package four pieces A, B, C, D as a group. Before usage connect the four pieces into whole using special bolts.

Key points of installation of mast

1. Two pieces with hoisting steps are connected together (D and B)
2. Two pieces with ladder fixing plate should be placed side to side (D and C), See Fig 9-1.
3. The whole mast needs 20 special bolts and the nuts should be inside, bolt top outside.
4. The pretension moment of bolt is  $1240\text{Nm}\pm 20\%$ .
5. Connecting plate of every piece should be mounted inside the angle steel.



**注意：**

在组装塔身节时，塔身节单片的联接板必须在主弦角钢的内侧。（如图9-1）如塔身节单片的联接板在主弦角钢的外侧，将导致平台安装不上与爬升架安装倾斜问题。

**Note: when assembling the tower mast, the connection plate of single piece of mast should be at the inner side of main chord angle steel. (as Fig 9-1) if the connection plate is at outside of angle steel, there will some problems: the platform would fail to mount or the climbing frame would be tilted.**

10.4.2 标准节通道

通道的基本形式是带有四个护身圈的爬梯，梯子长度3米。

爬梯要安装在标准节焊有顶升踏步的一侧。（见图10-2）

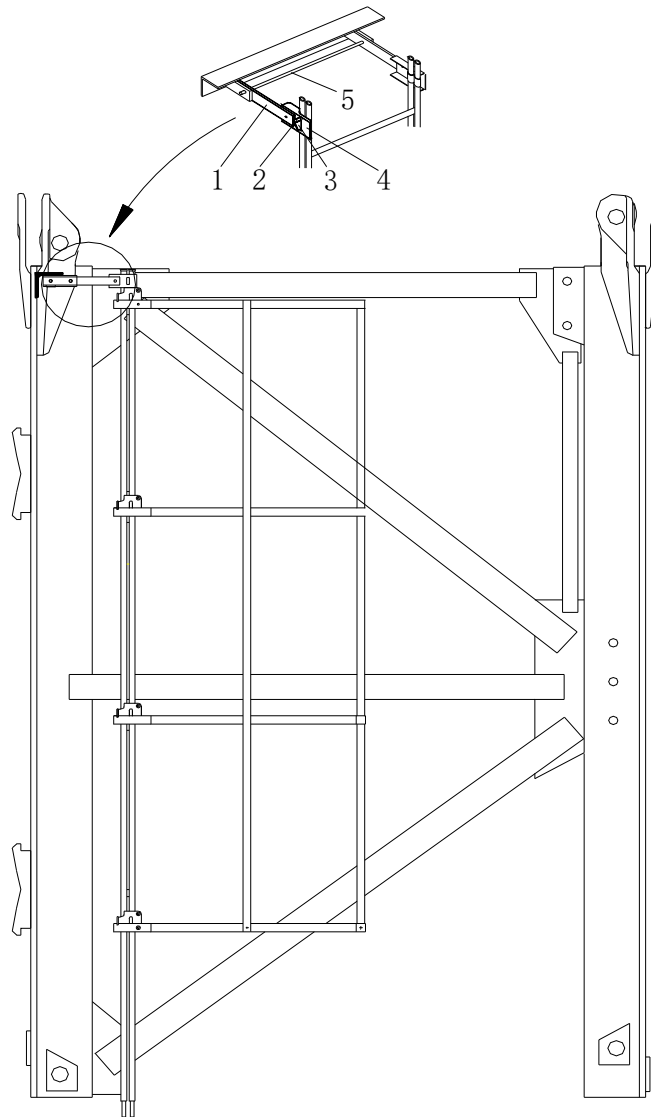
爬梯是在标准节组装完成以后，顶升以前安装好。安装完毕的爬梯下端可用铅丝固定在标准节下端，以防止顶升吊运时晃动。

### 10.4.2 Passage of mast

Passage basically includes two kinds. One is 3m with four guard ring.

Ladder is installed one side of mast with steps, see Fig 10-2.

Ladder is installed before the completion of hoisting mast. After installation, fix the bottom ladder at the bottom of mast with plumb to avoid swaying during hoisting and lifting.



- |           |           |
|-----------|-----------|
| 1 - 梯子联接架 | 2 - 楔板    |
| 3 - 梯子固定钩 | 4 - 梯子固定板 |
| 5 - 销轴    |           |

图 10-2

- |                            |                |                       |
|----------------------------|----------------|-----------------------|
| 1. Ladder connecting frame | 2. Wedge plate | 3. Ladder fixing hook |
| 4. Ladder fixing plate     | 5. Pin shaft   |                       |

Fig 10-2

### 10.4.3 标准节歇息平台

标准高度塔机共有 7 个休息平台。为配合歇息平台的安装爬梯变为只有两个护身圈在下部安装的形式。

爬梯要安装在标准节焊有顶升踏步一侧。

爬梯是在标准节组装完毕后，顶升以前安装好。为防止爬梯摆动可用铅丝将下端固定好。

将歇息平台开口方向对准爬梯放在标准节横腹杆上，用四个 M10×40 螺栓、固定垫板固定好（见图 10-3）。

插入两个序号 1 栏杆，用 8×70 开口销固定。将栏杆 2 用四个 8×70 开口销固定在栏杆 1 上（见图 10-3）。

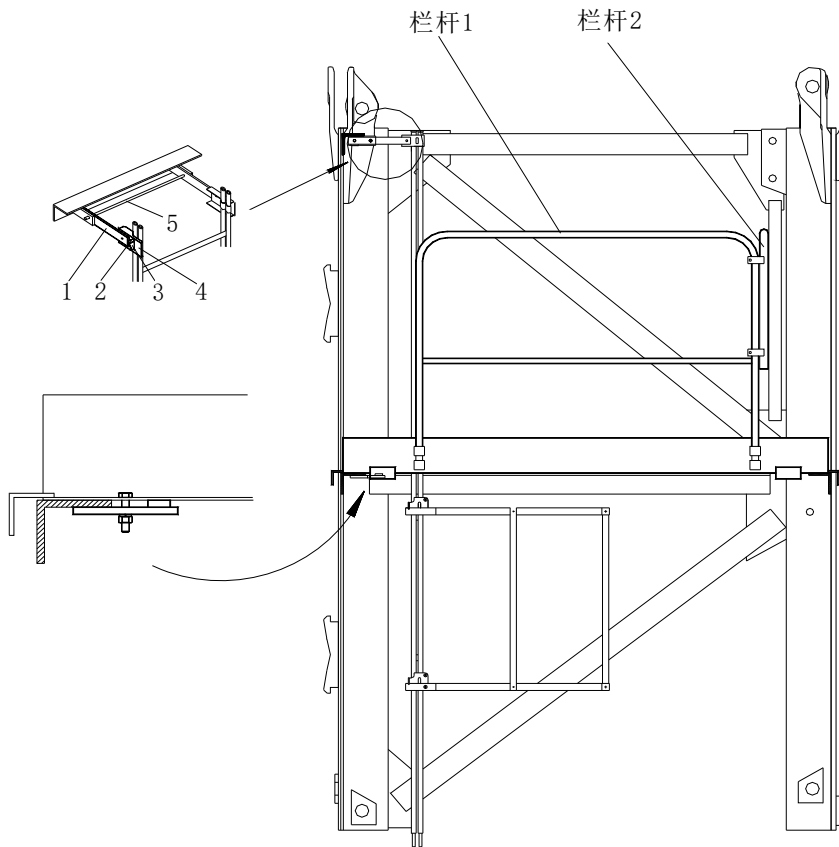
### 10.4.3 Mast resting platform

For standard-height tower crane, it has seven resting platform in total. For the convenience of mounting, the ladder is the kind with two guard rings at the bottom. Ladder is installed before the completion of hoisting mast.

After installation, fix the bottom ladder at the bottom of mast with lead wire to avoid swaying during hoisting and lifting.

The rest platform is open to ladder and place it on mast web member, fixing with four bolts of M10×40 and fixing plate. (Fig 10-3)

Insert two railings 1 and fixed with cotter pins of 8×70 and then place railing 2 on railing 1, fixing with four cotter pins of 8×70. (Fig 10-3)

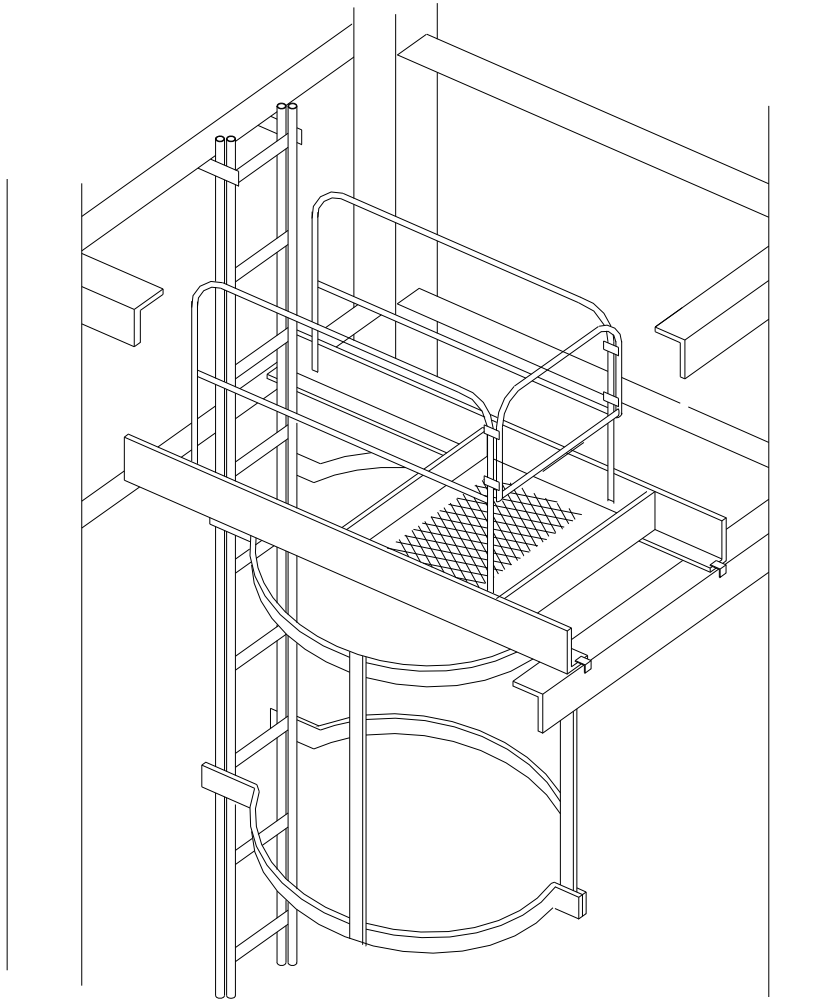


- 1 - 梯子联接架    2 - 楔板    3 - 梯子固定钩  
4 - 梯子固定板    5 - 销轴    6 - 固定垫板  
7 - 螺栓

1. Ladder connecting frame 2. Wedge plate 3. Ladder fixing hook 4. Ladder fixing plate  
5. Pin shaft 6. Fixing backing plate 7. Bolt

图 10-3

Fig 10-3 Platform installation



安装好的歇息平台见图 10-4。

The installed resting platform is shown in Fig 10-4.

图 10-4 Fig 10-4

歇息平台安装位置：

歇息平台在塔身上的具体位置应遵循如下原则：

- 1、每次顶升时最后一节应有一个歇息平台。
- 2、在塔机安装高度大于标准塔高时，每两个歇息平台间隔不大于四个标准节。

歇息平台具体位置参见表 10-1。

The principles of placing the two kinds of resting platforms on tower body are:

1. When hoisting each time the last mast ought to have one resting platform;

When the installing height of tower crane is more than its standard height, the distance between the passages with two resting platforms is not more than four masts.

The detailed position of resting platform is shown in Table 10-1.

表 10-1 Table 10-1

17	固定式安装 Fixed type installation																E	
16	行走式或底架固定式安装 Travelling or base frame fixed type installation															E	A	
15														E	A	A		
14														E	A	D	D	
13													E	A	D	A	A	
12												E	A	A	A	A	A	
11											E	A	D	D	D	D	D	
10										E	A	D	A	A	A	A	A	
9									E	A	A	A	A	A	A	A	A	
8								E	A	D	D	D	D	D	D	D	D	
7							E	A	D	A	A	A	A	A	A	A	A	
6						E	A	A	A	A	A	A	A	A	A	A	A	
5					E	A	D	D	D	D	D	D	D	D	D	D	D	
4				E	A	D	A	A	A	A	A	A	A	A	A	A	A	
3			E	A	A	A	A	A	A	A	A	A	A	A	A	A	A	
2		E	A	D	D	D	D	D	D	D	D	D	D	D	D	D	D	
1		E	A	D	A	A	A	A	A	A	A	A	A	A	A	A	A	
0																		
节数	0	1	2	3	4	5	6	7	8	9	10	11	12	13	14	15	16	17

表 5-1 通道组合表

Table 5-1 Aisle combination

注：0 表示基础节，1-17 表示标准节。

本通道组件与塔身标准节配套使用，有 A、D、E 三种型式。

该图的通道组合为固定附着式最高(201 米)塔身的组合，增加标准节时，可按通道

组合表类推；

每台塔机只有一套通道 E，E 与 D 区别在于 E 有门，当需要时可将 E 上门拆掉，安装在通道 D 上。通道 A、D 是按照标准节的配置并按通道组合表的规定组合进行组合安装的。

Note: 0 indicates the base section and 1 to 17 indicates the standard section.

The passage components are used together with the tower mast sections, including 3 types of A, D, E.

The passage combination in the figure is that of the highest tower bodies (201m) of the fixed and attached tower cranes. Mast section can be added according to the aisle combination table.

Each tower crane has only one set of passage E, which distinguishes itself from D with a door. The door on passage E can be dismantled and mounted to passage D when necessary. Passage A and D are assembly mounted with standard section configuration and according to the combination in passage combination table.

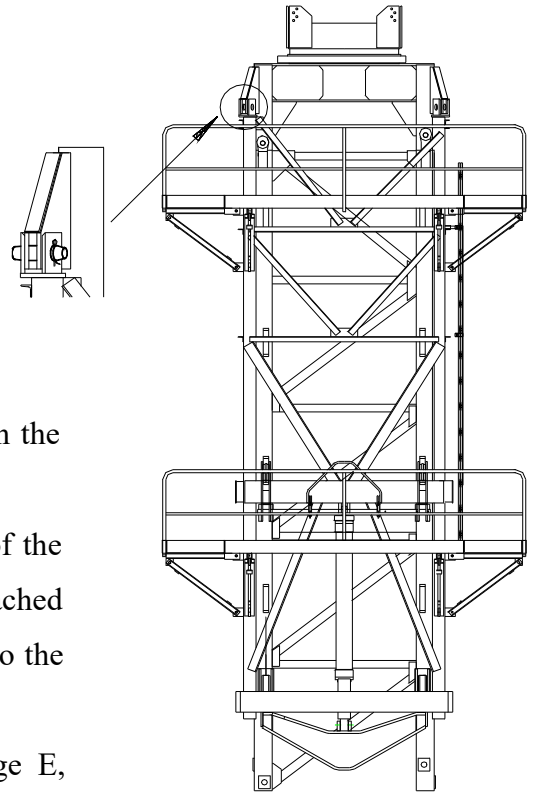


图 10-5 Fig 10-5

#### 10.4.4 联接顶升套架

联接顶升套架前必须使塔机液压系统工作正常，具体参见有关章节。

启动液压泵站，检查顶升横梁是否用制动板锁住，套架上换步制动靴是否处于打开位置。用液压缸将套架顶起。

当顶升套架与特殊节接近时，要注意回转特殊节上定位销与套架上定位孔的相对位置。如果不合适可用撬棍予以校正，使定位销插入定位孔中。继续使顶升套架上升直到套架上安装孔与特殊节安装孔对正为止。此时可以利用斜铁或手拉葫芦辅助找正位置。

用四根销轴将套架和特殊节联接起来，并用开口销固定。（见图 10-5）

#### 10.4.4 Connect the jacking frame

Before the jacking frame is connected, make sure the hydraulic system of the tower crane is operating normally. For details, see relevant sections.

Start the hydraulic pump station, and check whether the jacking beam is locked with

brake plate, and if the step-changing brake shoe on the frame is in open position. Jack up the frame with hydraulic cylinder.

When the jacking frame is close to the lower support, pay attention to the relative position of locating pin on the lower slewing ring support to the locating hole on the frame. If the position is not suitable, calibrate it with a crowbar and plug the locating pin into the locating hole. Continue to lift up the jacking frame until the mounting hole on the frame aligns with the one on lower support. In this case, wedge or chain block can be used for position alignment.

Connect the frame with the lower support with 4 pins and fix it with cotter pins. (see Figure 10-5)

#### 10.4.5 安装引进梁

安装引进梁方法：（见图 10-6）

用引进吊钩挂住引进梁前部圆钢并将引进梁提升到水平位置，拆下销轴，向后开动变幅小车，使引进梁后端到达安装孔位置，用销轴固定好。稍稍提升引进梁，使引进梁前安装孔就位，用销轴固定好。拆下引进梁支承板，摘下引进吊钩。

10.4.5 Methods of installing the introduction beam: (see Figure 10-6)

Hook the front round steel of the introduction beam with inlet hook and lift the beam to horizontal position; remove the pins and drive backward the trolley to make the rear end of the beam reach the mounting hole position, fix the beam with pins. Lift the introduction beam slightly and make the front mounting hole of the beam in position, fix the beam with pins. Remove the introduction beam support plate and take off the inlet hook.

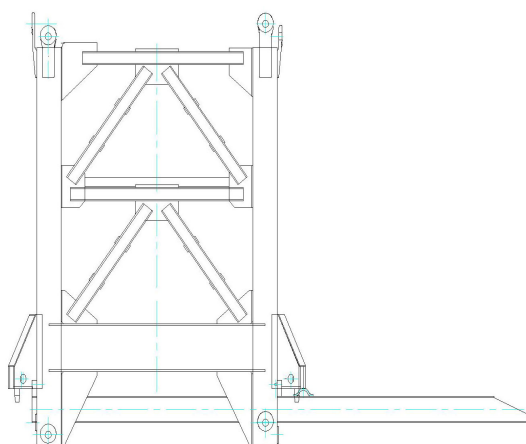


图 10-6 Fig 10-6

#### 10.4.6 顶升平衡

塔机顶升时应处于平衡状态。即塔机顶升以上部分的重心应落在液压油缸的轴心上。10.4.2 给出塔机不同臂架长度顶升时的理论平衡位置，此表只能作参考。实际工作中应根据具体情况做具体调整。现就顶升平衡问题作如下说明：

- 1、每一台塔机顶升时的平衡位置可能不同。
- 2、同一台塔机安装成不同的起重臂长度时，平衡位置不相同。

#### 10.4.6 Jacking balance

The tower crane should be balanced when jacking. That means the gravity center of upper jacked part should be on the axial center of hydraulic oil cylinder. 10.4.2 focuses on the theoretic balance position for reference. The actual position is subject to the actual condition. The following is notes about jacking balance:

1. The balance position of each tower crane may be different.
2. For the same tower crane, if the jib length is different, the balance position will be different.

顶升平衡方式有两种：

- 1、理论上在指定的幅度处悬吊载荷。
- 2、实际上调整载重小车在起重臂上的位置。

将液压泵站操纵杆推到《向上顶升》位置，向上顶升，直到回转下支座四条支腿刚刚离开鱼尾板为止。此时检查是否平衡，具体就是观察回转下支座支腿与过渡节主角钢是否在同一垂线上。

如果下支座四条支腿与过渡节主角钢在同一垂线上，说明平衡良好。

如果下支座四条支腿与过渡节主角钢不在同一垂线上，可根据偏移的方向调整载重小车的位置作出相应的调整。

Balance ways are two kinds:

1. Hang certain load at certain place.
2. Adjust the actual position of trolley on jib.

Push the joystick of hydraulic station to “up” position and conduct the jacking action until the four outriggers of slewing lower support is just separated from fishplates. At this time check whether the tower crane is in balance or not, which is to observe the outrigger of

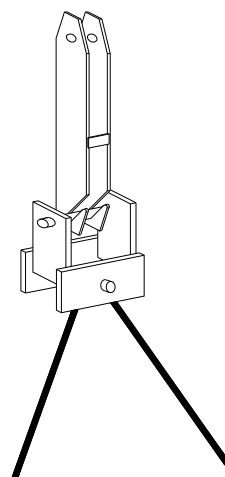


图 10-7  
Fig 10-7

lower support is in the same vertical line with main angle of transient.

If they are in the same vertical line, the tower crane is in good balance. If not, adjust the trolley position according to the excursion condition.

**注意** 要将液压泵站操纵杆推向《下降》位置，使塔机恢复到初始位置，然后移动载重小车。

重复上述步骤，检查平衡状态是否良好，直到达到理想平衡状态为止。

当塔机起重臂安装长度较短时，单靠载重小车的位置可能达不到要求，可在吊钩上悬吊一定重量的载荷。悬吊方法见图 10-7。

塔机平衡调整好以后应记住该位置，每次顶升时载重小车都应停在此处，必要时可做一标记。

**Caution** When adjusting the position of load trolley, push hydraulic pump station joystick to “Down” and recover tower crane to initial position. And then move the trolley.

Repeat above steps to check whether the crane is in good balance until it is in good balance.

When the mounting length of jib is two short and the trolley position may not meet the requirements, you can choose to hang some load on hook. the hanging method is shown in Fig 10-7.

Remember the position after tower crane is in balance. And stop the load trolley at this position each time. If necessary, mark the position.

#### 10.4.7 在引进梁上吊挂标准节

每次顶升作业前要把标准节挂在引进梁上，进行此项工作需专用的引进小车。

##### 10.4.7.1 用引进小车吊挂标准节

将引进吊钩挂在塔机吊钩上，用引进吊钩吊起引进小车。吊挂引进小车时注意使引进吊钩开口背向引进小车焊有挡板的方向，这样当引进小车吊挂在引进梁上以后容易摘钩。

将引进小车移至标准节上方，下降引进小车使引进小车四个吊环与标准节最上一层横腹杆上四个吊装孔对正。此时要注意引进小车的方向，应该使引进小车有挡板一侧靠近标准节焊有顶升踏步的一侧。

用塔机专门配制的四个鱼尾板螺栓将引进小车吊环与标准节联在一起。联接时螺母

不要拧得太紧，以防止拆卸时不方便（见图 10-8）。

#### 10.4.7 Suspend masts on the introduction beam

The masts shall be suspended on the inlet beam before all jacking operation and this requires dedicated inlet trolley.

##### 10.4.7.1 Use inlet trolley to suspend the mast

Hang the inlet hook to the tower crane hook and suspend the inlet trolley with inlet hook. When suspending the inlet trolley, note that the opening of the inlet hook shall face away from the inlet trolley side where baffle is welded so that the hook can be took off easily when the trolley is suspended at the inlet beam.

Move the inlet trolley over the mast and descend it to align the 4 hoisting rings of trolley with the 4 lifting holes on the uppermost horizontal web rod of the mast. At this moment, pay attention to the direction of the inlet trolley and the side with baffle shall near the mast side where climbing steps are welded.

Connect the hoisting rings of the inlet trolley to the mast by 4 fishplate bolts dedicated to tower crane. In connection, do not screw the nut too tightly so it will not be inconvenient to dismantle (See Fig 10-8)

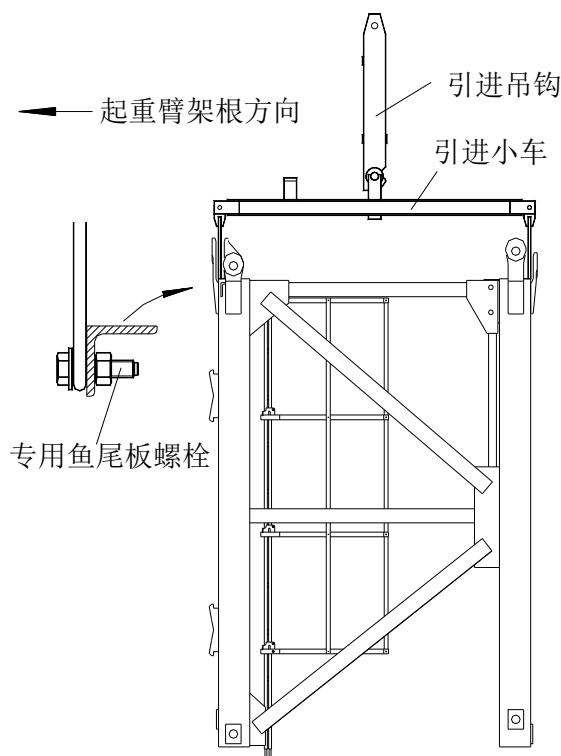


图 10-8 Fig 10-8

#### 10.4.7.2 在引进梁上悬挂标准节

提升已装好标准节的引进小车至引进梁高度，转动塔机使引进小车与引进梁对正。

向后移动载重小车使引进小车四个滚轮分别与两引进梁对齐，下降引进小车，使引进小车滚轮正好落入引进梁两侧。

继续下降吊钩，摘下引进吊钩。

轻轻向塔身方向拉动标准节，使其与塔身保持 0.5 米左右距离。并使其稳定（见图 10-9）。

#### 10.4.7.2 Suspend mast on inlet beam

Hoist the inlet trolley which has mounted with a mast to the inlet beam height and rotate the tower to align the trolley with the inlet beam.

Move backward the loading trolley and align the 4 rollers of trolley with the 2 inlet beams respectively; descend the trolley and make the rollers fall right into the two sides of introduction beam.

Continue to descend the inlet hook and take it off.

Pull the mast lightly toward the tower body direction until its distance to the tower body is about 0.5 meters, and then stabilize the mast (see Figure 10-9).

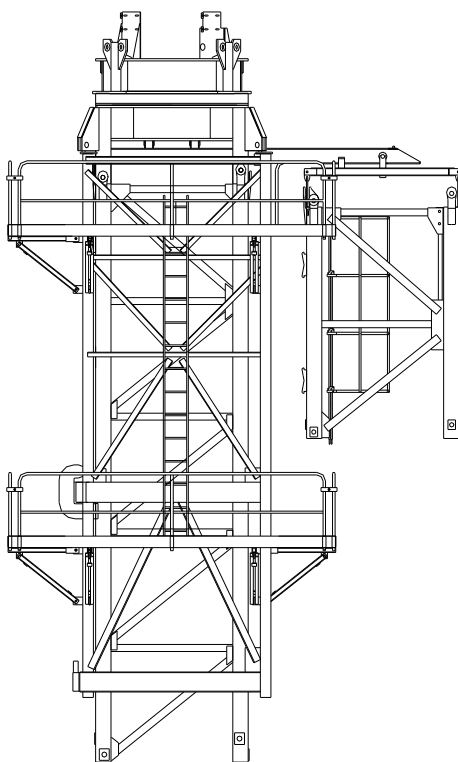


图 10-9 Fig 10-9

## 10.4.8 顶升作业

### 10.4.8.1 顶升作业的气象条件

顶升作业时对气象条件的要求如下：

- 1、塔机顶升期间允许的风速  
风平行于起重臂=16米/秒(相当于58公里/小时=风力7级)  
风垂直于起重臂=14米/秒(相当于50公里/小时=风力6级)
- 2、当有浓雾视线不清时禁止顶升作业。
- 3、当有雨、雪、结霜等容易造成滑落事故时禁止顶升作业。
- 4、当预报有强对流气象现象时（雷电、强阵风等），最好不要顶升作业。
- 5、夜间顶升作业时，要有充分、合理的照明方可进行。

### **10.4.8 Jacking operation announcements**

#### 10.4.8.1 Weather requirements of jacking operation are:

1. Wind speed at the highest point of tower crane:  
Wind parallel to jib: 16m/s (equal to 58km/h or wind force level 7)  
Wind vertical to jib: 14m/s (equal to 50km/h or wind force level 6)
2. No jacking operation when heavy foggy.
3. No jacking operation at the time when it is easy to cause slipping accident, for example, rain, snow, frost.
4. It is better not to jacking when there is going to have strong convection phenomenon, such as thunder and light and strong wind.
5. Sufficient illumination is needed when jacking at night.

#### 10.4.8.2 顶升前检查

每次顶升前应作如下项目的检查，只有条件许可才可以进行顶升作业。

- 1、气象条件良好。
- 2、需要加入的标准节已悬挂在引进梁上。
- 3、顶升横梁就位，且制动板已安放在顶升横梁挂靴内。
- 4、液压系统工作正常。
- 5、拆下塔身与回转支承联接的八个销轴，用四个顶升用临时销轴代替。
- 6、顶升平衡已找好位置。
- 7、整理塔机电源线，防止在顶升过程中将电源线拉断。



**注意**

**塔机顶升作业危险性较大，以上各项检查必须全都合格才可以进行。只**

**要以上各项中有一项达不到要求，坚决不能进行顶升作业，以防事故发生。**

#### 10.4.8.2 Inspection before jacking

Do the following inspection before jacking each time, and jack as long as the condition permits.

1. Weather condition is good.
2. The masts which are going to be added have hung on introduction beam already.
3. Introduction beam has taken its place already and brake plates have been put into hanging boot of introduction beam.
4. Hydraulic system functions well.
5. Remove the eight pins connecting tower body and lower support and replace them by four temporary jacking pins.
6. Jacking balance is positioned.
7. Settle power line of tower crane so as to it is not broken during jacking.



**Caution**

**The jacking operation is very serious, so only all this steps are inspected to be as required can you continue the jacking operation, otherwise it will cause serious consequence.**

#### 10.4.8.3 顶升程序

顶升作业由三个人配合，一人负责操作泵站、二人负责操作顶升横梁挂靴。

- 1、启动液压泵站。
- 2、拆下四个临时销轴。
- 3、打开顶升套架上支承爬爪操纵杆，使支承爬爪与塔身分开。
- 4、液压泵站操纵杆搬向《向上》位置，液压油缸带动套架以上部分向上运动(图 10-10 中序号 1)。
- 5、当液压油缸活塞接近下止点位置时，推动顶升套架上支承爬爪操纵杆使支承爬爪与塔身主角钢贴紧，将液压泵站操纵杆搬向《向下》位置，使塔机套架以上部分临时固定在顶升踏步上（见图 10-10 中序号 2）。
- 6、拿掉顶升横梁挂靴内的制动板。
- 7、液压泵站操纵杆搬向《向下》位置使顶升横梁收回。在收回的过程中，注意不要

使顶升横梁与塔身上螺栓或鱼尾板卡住，防止造成事故。

- 8、当顶升横梁挂靴与上一级顶升踏步对齐时，向塔身方向搬动顶升横梁使挂靴挂在顶升踏步上（见图 10-10 中序号 3）。
- 9、轻轻将液压泵站操纵杆搬向《向上》位置使顶升横梁挂靴在顶升踏步上挂实，将制动板塞入顶升横梁挂靴内。
- 10、液压泵站操纵杆搬向《向上》位置，继续顶升。当支撑爬爪与塔身顶升踏步分开以后及时将爬爪搬到打开位置。（见图 10-10 中序号 4）。
- 11、该过程要重复三次方能形成可将一节标准节放进顶升套架内的空间。

### 10.4.8.3 Jacking Operation

#### 10.4.8.3.1 Jacking procedures

The jacking operation is accomplished by three people, one for operating the pump station and another two for operating jacking beam boot.

1. Start the hydraulic pump station.
2. Remove the 4 temporary pins.
3. Open the control lever of supporting climbing claw on jacking frame and separate the supporting climbing claw from tower body.
4. Push the control lever of hydraulic pump station to “up” position and the hydraulic cylinder drives the part above frame to move upward. (Fig 10-10, No.1)
5. When hydraulic cylinder piston is close to the bottom dead center, push the control lever of supporting climbing claw on jacking frame so that the supporting climbing claw is close to main angle steel of the tower body. Push the control lever of hydraulic pump station to “down” position and make the portion above the frame fixed on the climbing step temporarily. (Fig 10-10, No.2)
5. Take off the brake plate within the jacking beam boot.
7. Push the control lever of hydraulic pump station to “down” position and retract the jacking beam. During retracting, be careful not to stick the jacking beam by bolt or fish plate on the tower body so as to avoid accident.
8. When jacking beam boot aligns with the higher stage of the climbing steps, move the beam towards the tower body to hang the boot on the climbing step. (Fig 10-10, No.3)
9. Push the control lever of hydraulic pump station lightly to “up” position so that the jacking beam boot hang on the climbing step solidly, plug the brake plate into jacking beam boot.
10. Push the control lever of hydraulic pump station to “up” position and continue the

jacking operation. After separating supporting climbing claw from climbing step, push the latch to open position timely. (Fig 10-10, No.4)

11. The procedure needs to be repeated for three times to form the space used for accommodating one mast in the jacking frame.

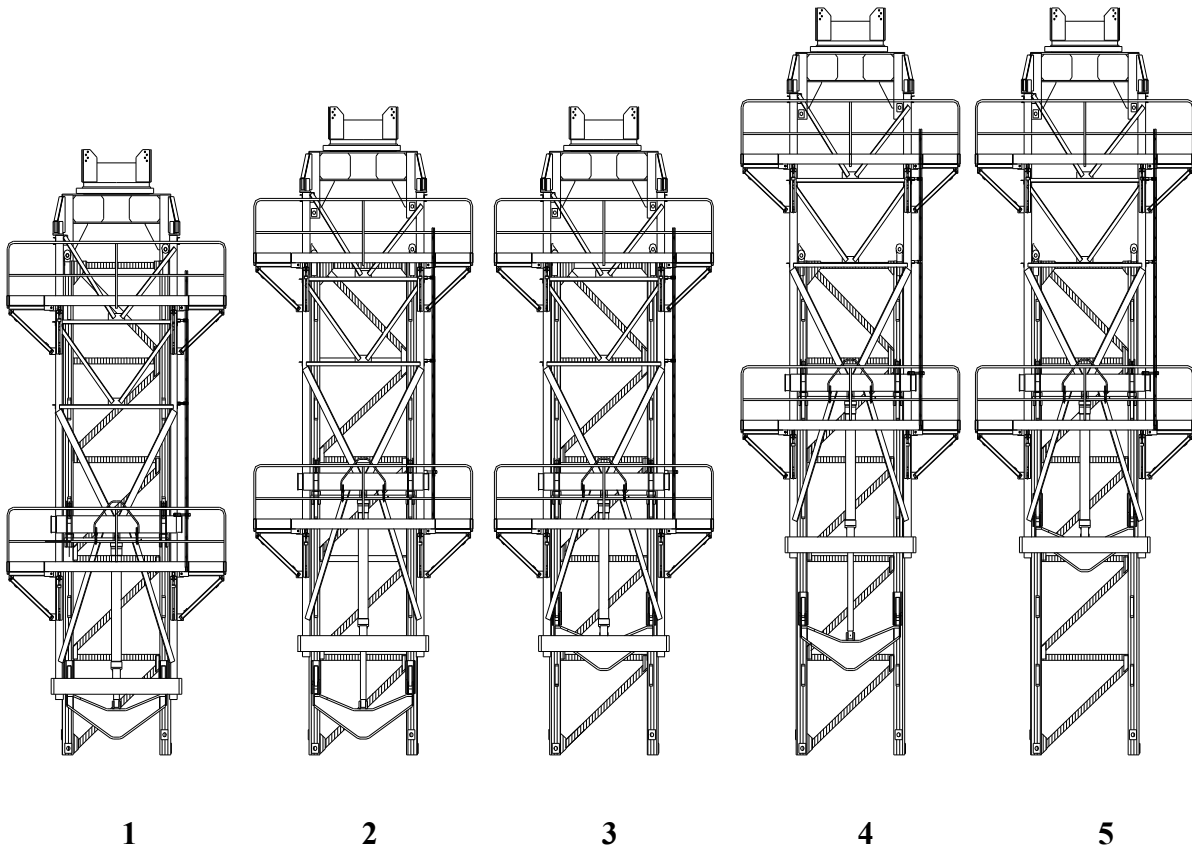


图 10-10 Fig 10-10

## 10.4.8.4 引进标准节

- 1、当顶升第三循环接近完成、顶升套架内空间可以容纳标准节时，将挂在引进梁上的标准节轻轻推向塔身、引入套架内。
- 2、液压泵站操纵杆搬向《向下》位置，引进的标准节下端与塔身原标准节上端鱼尾板对齐相联，打入八个标准节联接销轴，并用锁销固定。在联接标准节时注意使两标准节上爬梯对正，上下插接在一起。
- 3、拆下引进小车上四条固定标准节的螺栓，将螺栓装在引进小车吊环内。向外推出引进小车至标准节以外位置。
- 4、继续下降顶升套架使下支座四个支腿落在新安装好的标准节上端鱼尾板内。用顶升套架上附带的四个临时固定销轴将下支座与标准节联接起来。

## 10.4.8.4 Introduction of the mast

1. When the third cycle of jacking operation is about to end and the space within the jacking frame can accommodate the mast, push the mast hanging on the introduction beam toward the tower body and import it into the frame.

2. Push the control lever of hydraulic pump station to “down” position, the lower end of the imported mast shall align with and be connected with the upper fish plate of the original mast on tower body; plug 8 mast connecting pins and fix the shafts with lock pin. When connecting the masts, note that the ladder of two sections shall be aligned and upper and lower parts shall be connected.

3. Remove the 4 bolts which fix the mast to the inlet trolley and mount the bolts to the hoisting rings of the trolley. Push the inlet trolley outward to the position outside the mast.

4. Continue to descend the jacking frame and let the 4 outriggers of the lower support drop into the upper fish plate of the newly installed mast. Connect the lower support with the mast by using the 4 temporary fixing pins attached on the jacking frame.



**在四个临时销轴没有安装以前，塔机不能做任何动作（包括小车、起升和回转）。否则有可能造成塔机倾翻的事故。**

关于顶升用临时销轴的说明：

为方便顶升作业，在顶升套架上端四角焊有四个带链的临时销轴，此销轴直径比标准节销轴小 2mm 。

此销轴只做顶升时联接下支座与塔身用，塔机正式作业时不允许用此销轴替代标准

节销轴。



**No action (including trolley, lifting and swinging) is allowed for the tower crane before the 4 temporary pins are installed. Otherwise severe damages and casualties may be caused.**

Instruction about the temporary pins used for jacking:

For convenience of jacking operation, 4 temporary chain pins are welded on the 4 upper corners of jacking frame. The diameter of the pin is 2mm shorter than the one for mast.

This pin is only used for connecting the lower support with tower body during jacking, and it is not allowed to replace the mast pin with this pin during normal operation.

#### 10.4.8.5 在引进梁上吊挂第二节标准节

当塔身与下支座临时固定后，可以吊装第二节标准节。

- 1、收回载重小车。
- 2、用引进吊钩挂住引进小车稍稍提起并向前运动，使引进小车与引进梁分离。
- 3、下降塔机吊钩，用前面所述方法吊挂装好爬梯或休息平台的标准节。
- 4、吊起标准节，用前面所述方法将标准节悬挂在引进梁上。
- 5、载重小车回到顶升时的平衡位置。
- 6、拆下临时固定销轴，开始第二个顶升程序。
- 7、重复上述顶升程序，直到塔机顶升作业完成为止。

#### 10.4.8.5 Suspend the second mast on introduction beam

The second mast can be hoisted after the tower body and lower support are temporarily fixed.

1. Retract the loading trolley.
2. Hook the inlet trolley with inlet hook, lift it up slightly and move forward to separate it from the introduction beam.
3. Descend the tower crane hook and use the previously described method to suspend and mount the ladder or the mast of rest platform.
3. Lift the mast and suspend it on introduction beam by previously described method.
5. Operate the loading trolley back to the balance position during jacking.
6. Remove the temporary fixing pins and start the second jacking procedure.
7. Repeat the above jacking procedure until the tower crane finishes jacking operation.

#### 10.4.8.6 结束顶升作业

当顶升作业全部完成时，要注意下列事项：

- 1、最后一节标准节要带有休息平台。
- 2、引进小车不要放在塔身内。
- 3、必要时可以放下引进梁。
- 4、特殊节与塔身必须用八个标准节销轴联接好并用锁销固定。
- 5、顶升横梁必须轻挂在最后一级顶升踏步上，注意要使液压油缸卸荷。
- 6、拆掉液压泵站的电源线。
- 7、整理好塔机电源随线。

#### 10.4.8.6 End the jacking operation

The following precautions shall be observed after the jacking operation is finished:

1. The last mast shall have a rest platform.
2. Do not put the inlet trolley in tower body.
3. The introduction beam may be put down where necessary.
4. Special section must be connected to the tower body with 8 mast pins and fixed with lock pins.
5. Jacking beam must be hitched lightly on the last stage of climbing step. Please note that the hydraulic cylinder shall be unloaded.
6. Remove the power supply lines from hydraulic pump station.
7. Put the power supply lines of tower crane in order.



整个塔机安装完毕后，将爬升架降到塔身最底部，固定牢固，以降低风载。

#### 10.4.9 标准节的拆卸

拆卸程序与顶升程序正好相反。拆卸的准备与顶升相同。平衡条件与顶升时相同。应注意泵站油温，过高时要间歇拆卸，尤其在夏天更应该注意。

##### 10.4.9.1 从塔身上拆卸标准节

- 1、用引进吊钩吊挂引进小车安放到引进梁上。
- 2、载重小车开到顶升平衡位置。
- 3、拆除塔身与回转支承相联接的八个销轴。
- 4、**检查顶升梁挂靴内制动挡板是否安放到位。**

5、**检查爬升架上支承爬爪是否处于打开位置。**

- 6、启动液压泵站，将操纵杆搬向《向上》位置使顶升套架以上部分向上顶起一段距离。
- 7、将引进小车拉进塔身内，用四个鱼尾板螺栓把引进小车与要拆除的标准节联接在一起。
- 8、拆除标准节下面与塔身相联接的八个销轴。
- 9、继续向上顶升，使要拆除的标准节与塔身脱离。
- 10、将要拆除的标准节推出塔身以外。



**After the installation of the whole tower crane, descend the jacking**

**frame to the bottom of tower body and fix it firmly to reduce the wind load.**

10.4.9 Disassembly of the mast

The disassembly procedure is opposite to the jacking procedure. Preparation of disassembly is same as that of jacking. The balance condition is also same with that of jacking. Pay attention to the oil temperature in pump station, especially in summer. The mast shall be dismantled intermittently if the temperature goes too high.

10.4.9.1 Dismantle the mast from tower body

1. Lift the inlet trolley with the inlet hook and place it on the introduction beam.
2. Drive the loading trolley to the balance position of jacking.
3. Remove the eight pins which connect the tower body with the slewing bearing.
4. Check whether the brake baffle within the jacking beam boot is put in place.
5. Check whether the supporting climbing claw on the jacking frame is in open position
6. Start the hydraulic pump station and push the control lever to “up” position to make the part above the jacking frame lifted up a distance.
7. Pull the inlet trolley into tower body and connect it to the mast which is to be dismantled by using 4 fish plate bolts.
8. Remove the eight pins from the lower end of the mast which connect the mast to tower body.
9. Continue to lift and separate the mast which is to be dismantled from tower body.
10. Push out the mast which is to be dismantled out the tower body.

- 11、搬动液压泵站操纵杆到《向下》位置，下降顶升套架，直至套架上支承爬爪与

塔身上顶升踏步套在一起，使顶升以上部分临时固定在支承爬爪上。

- 12、拆下顶升横梁挂靴内制动挡板，搬动液压泵站操纵杆到《向下》位置，同时向外推动顶升横梁使顶升横梁挂靴与顶升踏步分离。
- 13、搬动液压泵站操纵杆到《向上》位置，使液压油缸活塞杆向外伸出。
- 14、当液压油缸活塞杆伸出接近下止点时，将顶升横梁挂靴挂在顶升踏步上，并安放好制动挡板。
- 15、搬动液压泵站操纵杆到《向上》位置，使顶升套架支承爬爪与顶升踏步分离，将支承爬爪操纵杆向外拉动，使支承爬爪处于打开位置。
- 16、搬动液压泵站操纵杆到《向下》位置，继续下降顶升套架。

以上程序重复三次使回转支承与塔身重新联接在一起，并用四个临时销轴将回转支承与塔身固定好。

11. Push the control lever of hydraulic pump station to the “down” position and descend the jacking frame until the supporting climbing claw of the frame is hooked together with the climbing step on the tower body, make the part above the jacking fixed on the supporting climbing claw temporarily.

12. Remove the brake baffle in the jacking beam boot and push the control lever of hydraulic pump station to the “down” position, meanwhile, push the jacking beam outward and separate its boot from the climbing step.

13. Push the control lever of hydraulic pump station to the “up” position and make the hydraulic cylinder piston rod stretch outward.

14. When the hydraulic cylinder piston rod stretches close to the bottom dead center, hang the jacking beam boot on the climbing step and put the brake baffle in place.

15. Push the control lever of hydraulic pump station to the “up” position and separate the supporting climbing claw of the jacking frame from climbing step; pull the control lever of supporting climbing claw outward and make the latch in open position.

16. Push the control lever of hydraulic pump station to the “down” position and continue to descend the jacking frame.

Repeat the above procedures for three times to make the slewing bearing reconnect to the tower body, and fix the slewing bearing and the tower body with 4 temporary pins.

#### 10.4.9.2 将标准节降至地面

- 1、载重小车回到引进小车上方。

- 2、用引进吊钩挂住引进小车横梁，将要拆卸的标准节轻轻吊起。
- 3、开动载重小车向前运动，使引进小车与引进梁分离。
- 4、下降塔机吊钩将标准节放至地面，拆下引进小车与标准节联接的四条鱼尾板螺栓使引进小车与标准节分离。重新将鱼尾板螺栓装到引进小车吊环上。
- 5、上升塔机吊钩将引进小车挂在引进梁上。

#### 10.4.9.3 结束拆卸标准节作业

当最后一节标准节落至地面后，从塔机吊钩上摘下引进吊钩并将塔机吊钩上升至最高位置。

用八个标准节销轴将下支座与标准节联接好。

#### 10.4.9.2 Descend the mast to ground

1. Drive the loading trolley to the top of the inlet trolley.
2. Hitch the beam of the inlet trolley with inlet hook and lift the mast which is to be dismantled slightly.

3. Drive forward the loading trolley to separate the inlet trolley from the introduction beam.

4. Descend the tower crane hook and put the mast to the ground, remove the 4 fish plate bolts which connect the inlet trolley to the mast and separate the trolley from the mast.

Reinstall the fish plate bolts to the hoisting rings of the inlet trolley.

5. Ascend the tower crane hook and hang the inlet trolley on introduction beam.

#### 10.4.9.3 End the operation of mast disassembly

When the last mast falls to the ground, take off the inlet hook from the tower crane hook and ascend the tower crane hook to the highest position.

Connect the lower support to the mast with 8 mast pins.

#### 10.4.10 塔机准备作业

移动变幅小车，放下平衡配重并再次检查塔身的连接。

#### 10.4.11 顶升套架的落下

当塔机在运行时，建议将顶升套架下降至地面。

对于最大高度的塔身，顶升套架必须在底部位置拆除。对于下落顶升套架的程序与顶升程序相反。

#### 10.5 塔机的附着及安装

当塔机使用高度超过塔机自由高度时，应采取附着措施。

在确定塔机位置时就应考虑塔机的附着问题。

#### 10.5.1 附着点的布置

塔机附着点的确定可分为在垂直方向上附着点的确定和在水平方向上附着点的确定。

##### 10.5.1.1 垂直方向上的附着点

当塔机计划使用总高度确定以后，可以遵循以下原则确定垂直方向上的附着点。（见图 10-11）

#### 10.4.10 Preparation of the Tower Crane Operation

Move the trolley, put down the Counter weight and recheck the connection of the tower body.

#### 10.4.11 Lowering Down of the Jacking Frame

It is recommended to lower the jacking frame down to ground when the tower crane is in operation.

For the tower body with the maximum height, the jacking frame must be dismantled at the bottom of the tower body. The lowering down procedure of the jacking frame is opposite to the jacking procedure.

#### 10.5 Adhesion and installation of tower crane

When the needed height is over the free height of tower crane, the adhesion is required.

So before the certain of tower crane position, take the adhesion issue into consideration.

##### 10.5.1 Adhesion allocation

The adhesion allocation includes the adhesion point confirmation vertically and horizontally.

##### 10.5.1.1 Vertical adhesion point

When the planned height of tower crane is certain, identify the vertical adhesion point based on Table 10-11.

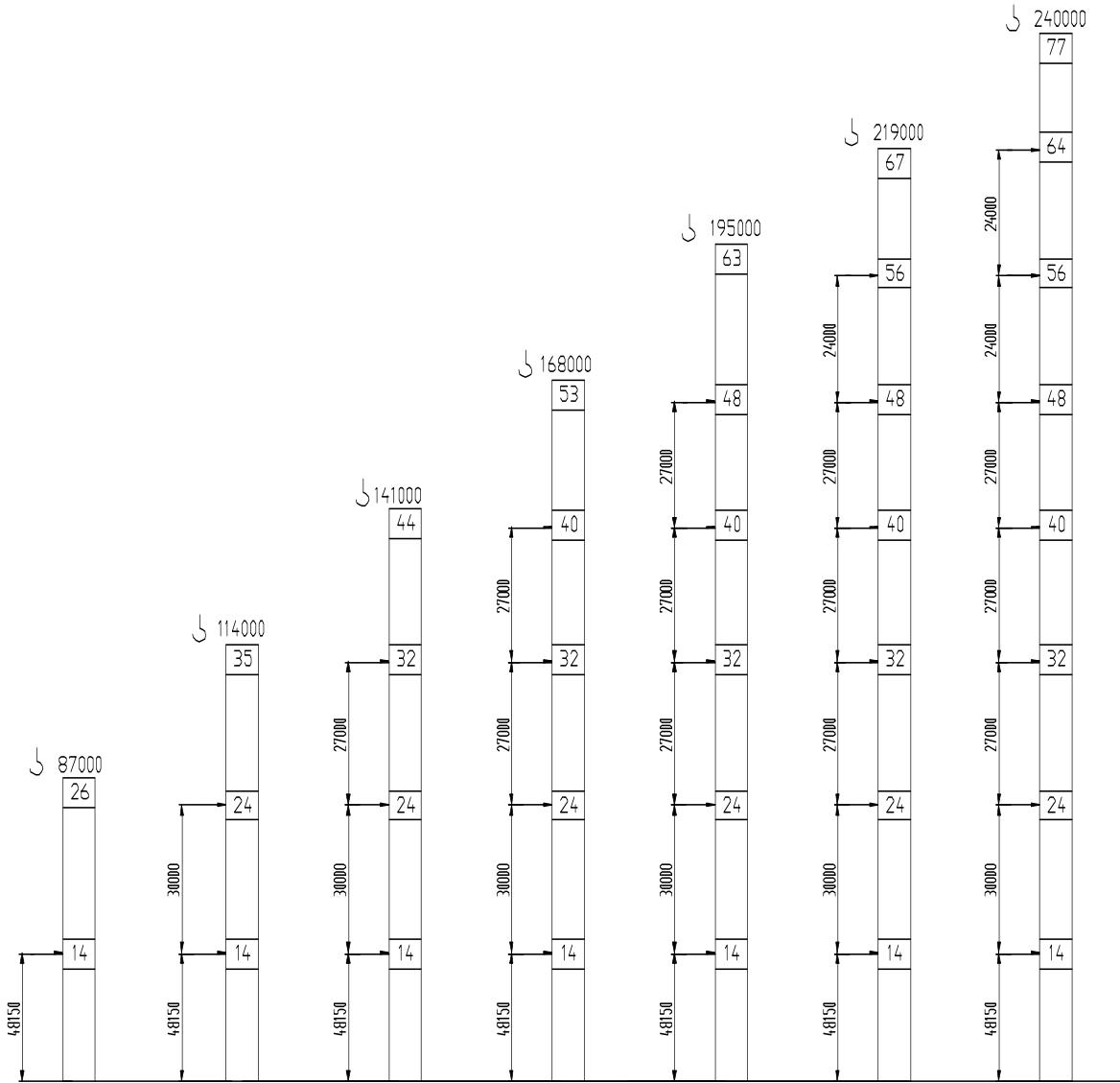


图 10-11 附着架附着尺寸

Fig 10-11 Tie frame size and position

10.5.1.2 水平方向上的附着点

在水平方向上布置附着点没有定式，可根据建筑物具体情况灵活变化。但要遵循以下原则：

10.5.1.2.1 最外侧两根撑杆与附着框架前梁垂线之间的夹角应在  $40^{\circ}\sim 60^{\circ}$  之间（四杆形式）或  $15^{\circ}\sim 45^{\circ}$  之间（三杆形式）。

10.5.1.2.2 最外侧两根撑杆最好对称安装，尽量避免相差太大。

10.5.1.2.3 附着点最好选取建筑物的拐角、或成 T 字的部位，以加大建筑物对撑杆的承载能力。

10.5.1.2.4 最好多作几种附着方案进行比较，选取附着点受力最小的方案。

10.5.1.2.5 如果撑杆支座在建筑物上能作两个方向的安装（如拐角处，立柱上）时，应将其安装在固定螺栓受剪切力较小的方向上。

10.5.1.2.6 在选定附着的位置上，建筑物应根据附着撑杆所受的拉、压力进行适当的加强。

10.5.1.2.7 对附着点的受力情况应作计算，不要盲目作出决定。

附着撑杆安装形式较多，下面给出两种最常用的形式（见图 10-12、10-13）。

#### 10.5.1.2 Horizontal adhesion point

There is no certain allocation of horizontal adhesion, so it is subject to the changes of building situation, with following below principles:

10.5.1.2.1 The angle between the two outboard stay-bars and the front-beam vertical of the attached frame is from  $40^{\circ}$  to  $60^{\circ}$  (four poles), or else  $15^{\circ}$  to  $45^{\circ}$  (three poles)

10.5.1.2.2 The two outboard stay-bars had better be assembled symmetrically, and mostly avoid difference.

10.5.1.2.3 The attached points had better laid at the building corner or T part, to increase the bearing force of the building.

10.5.1.2.4 You'd better make several attaching plans to compare, and choose the plan which the attaching point bears least force.

10.5.1.2.5 If the supporting-seat of the stay-bar could be fixed in 2 directions (e.g. at the corner, on the upright post); it should be fixed on the direction when the standing bolt bears the least shearing force.

10.5.1.2.6 At the chosen attached position, reinforce the building according to the pulling force and pressure born by the stay-bar.

10.5.1.2.7 Calculate the force of the attaching points, and don't make a decision aimlessly.

There are many ways of installing stay-bar, and here are 2 normal ways (Fig 10-12, 10-13).

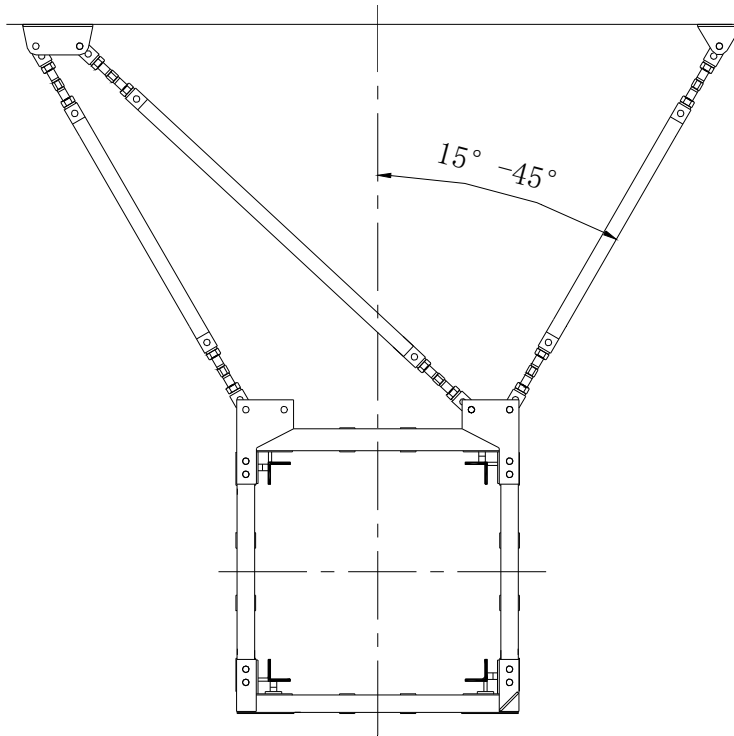


图 10-12 Fig 10-12

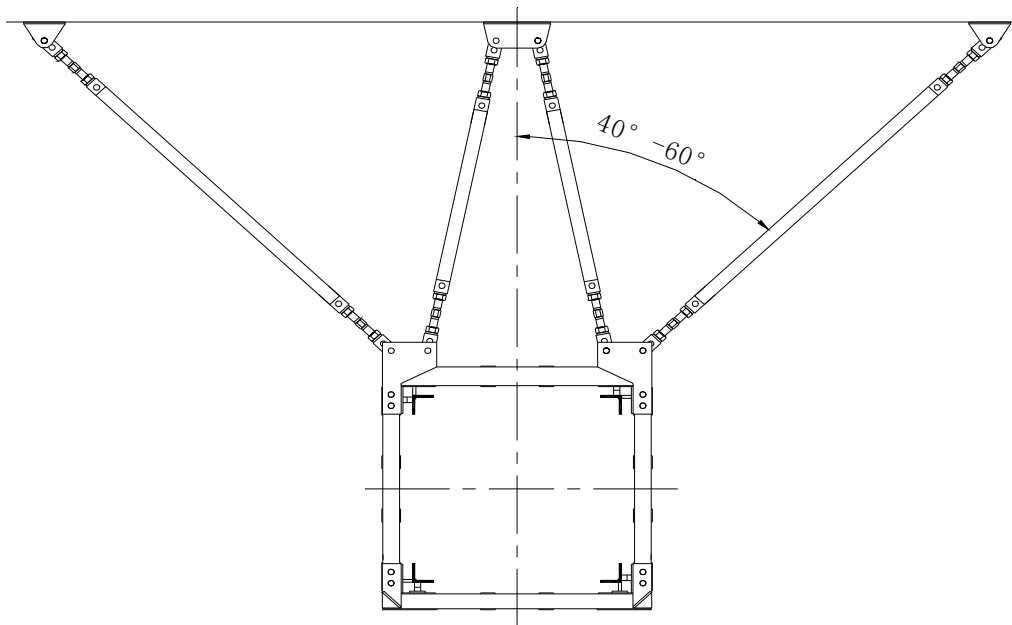


图 10-13 Fig 10-13

### 10.5.2 附着撑杆

由于塔机在每次附着时位置都可能不相同，所以附着撑杆的长度是不确定的。应根据实际距离设计撑杆。有关撑杆的设计要注意如下问题：

10.5.2.1 首先要计算每根撑杆所受的轴向力，选取受力最大的一根作为撑杆设计依据。

10.5.2.2 如果附着撑杆长度较长时，应考虑由于撑杆自重产生的附加弯矩对撑杆受力的影响。

10.5.2.3 如果附着撑杆长度较长时，可采取将撑杆分成几段制作、到现场组装的形式。这时对撑杆的联接形式、联接强度要考虑周全。

### 10.5.2 The attached strut

The attached strut should be designed according to the real distance, for the length of the attached strut couldn't be fixed because the crane's position may change every time when it is attached. NOTES of the design of the attached strut:

10.5.2.1 Firstly, calculate the axial-force bearing by each attached strut, and then choose the attached strut which bears the biggest force as the model.

10.5.2.2 If the attached strut is too long, it is necessary to take the extra-bending moment caused by the stay-bar's weight itself into count.

10.5.2.3 If the attached strut is too long, you can make it in several parts, and then assemble them at the worksite. At this time, you'd better to consider fully about the connecting-pattern and connecting-strength.

### 10.5.3 附着框

附着框在塔机附着时固定在塔身上，由下列部件组成：

### 10.5.3 Tie frame

The tie frame is fixed on the tower crane, when the crane is attached. And it is made up of the following parts:

- |        |         |         |       |
|--------|---------|---------|-------|
| 1、外框楔块 | 2、双锥头销轴 | 3、双锥头销轴 | 4、斜撑杆 |
| 5、卡箍楔块 | 6、垫板    | 7、前梁    | 8、卡箍  |
| 9、侧梁   | 10、卡箍   | 11、后梁   |       |

1. Outside wedge
2. Double cone-head pin
3. Double cone-head pin
4. Angling strut
5. Hoop wedge
6. Backing plate
7. Front beam
8. Hoop
9. Side beam
10. Hoop
11. Rear beam

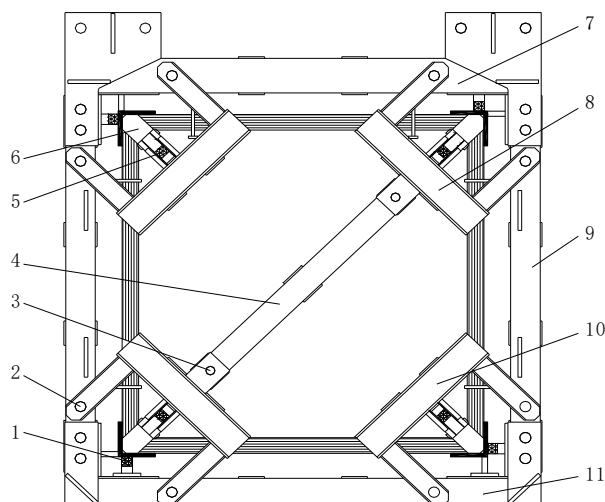
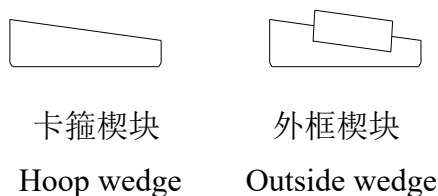


图 10-14 Fig 10-14



卡箍楔块      外框楔块  
Hoop wedge      Outside wedge

图 10-15 Fig 10-15

#### 10.5.4 安装附着框

首先在准备安装附着框的标准节上搭建一临时平台。

10.5.4.1 吊起前梁 7 至安装高度使朝向建筑物一侧，使前梁上两块支承板卡在标准节横腹杆上。用一手拉葫芦将前梁临时固定在塔身上（见图 10-16、图 10-17）。

#### 10.5.4 Installing the frame-attachment

Firstly, set up a platform around the section which to be attached.

10.5.4.1 Hang up the girder 7 to the side of building, and lock it on the section, using a chain block fix it. (Referring to Fig 10-16, and 10-17)

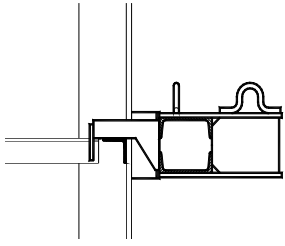


图 10-16  
Fig 10-16

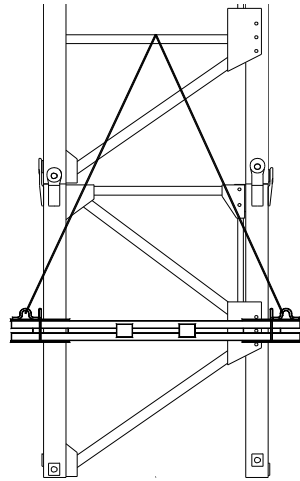


图 10-17  
Fig 10-17

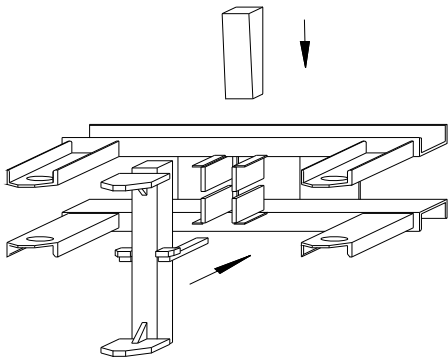


图 10-18  
Fig 10-18

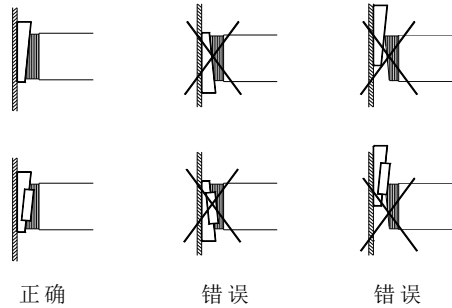


图 10-19  
Fig 10-19

10.5.4.2 吊起一侧梁 9 至塔身侧面，用两根双锥头销轴将侧梁与前梁相联接。

10.5.4.3 吊起另一侧梁安装到塔身另一侧。

10.5.4.4 吊起后梁 11 至塔身与前梁相对一面，用 4 根双锥头销轴将后梁与两侧梁相联接。

10.5.4.5 将垫板 6 插入卡箍 8 内，用铅丝临时固定好。此时要注意楔块安装时的方向，不要装反（见图 10-18）。

10.5.4.6 吊起卡箍 8 至塔身内侧，按图 10-16 所示用两根双锥头销轴将其与框架相联接。

10.5.4.7 用相同方法安装其它卡箍，注意要使有斜撑杆安装耳板的两卡箍安装在塔身对角上。

10.5.4.8 吊起斜撑杆至塔身内，用两根双锥头销轴将其安装在两卡箍上（见图 10-15）。

10.5.4.9 调整好附着框架水平位置。

10.5.4.10 在附着框架与塔身主角钢之间放入外框楔块，轻轻敲紧。

10.5.4.11 在卡箍内垫板与塔身主角钢之间放入卡箍楔块，轻轻敲紧。楔块的安装方向见图（10-19）。

10.5.4.12 检查框架与塔身之间是否贴合紧密，将所有楔块打紧、打实。

10.5.4.13 将附着架附带的专用爬梯装在标准节上。

10.5.4.2 Hang up the girder 9 to the flank of the section and connecting the cross girder and front girder with tapered pin.

10.5.4.3 Hang up the other girder at the other side.

10.5.4.4 Hang up back girder 11 at the back side and connect it to side girder with four tapered pins.

10.5.4.5 Put base plate 6 into clamp 8, fixed it with lead wire. Pay attention the direction of wedge block (referring to Fig 10-18).

10.5.4.6 Hang up clamp 8 into section internal, connecting it to frame with tapered pin.

10.5.4.7 Using the same method install other clamps and pay attention to that put the lug clamps at the cross position.

10.5.4.8 Lift up the sway rod to the internal of section, and connect it to the lug clamps with two tapered pins. (Referring to Fig 10-15)

10.5.4.9 Adjust the balance position of tie frame.

10.5.4.10 Put the outside wedge between the frame and the main angle steel of tower body. Fix it lightly.

10.5.4.11 Put the loop wedge between the base plate and the main angle steel. (Referring to Figure 10-19)

10.5.4.12 Check and confirm the frame and tower body be tight, and all wedge blocks must be tight enough.

10.5.4.13 Place the special ladder of tie frame on mast.

## 10.5.5 安装附着撑杆

10.5.5.1 在地面按计算长度调整好撑杆的长度，分别吊装至各自的位置，两端用双锥头销轴固定好。

10.5.5.2 用经纬仪检查塔身垂直度，如果不符合要求可用撑杆上调整丝杠来调整，直到塔身侧向垂直度在千分之四以内。

10.5.5.3 锁紧撑杆两端螺母。此项工作必须仔细认真，不能马虎从事。

附着后的塔机在正常工作中应经常检查附着撑杆两端锁紧螺母和建筑物上撑杆支座固定螺栓的锁紧情况，如发现有松动现象要及时锁紧，以免事故发生。

## 10.6 附着式塔机的拆卸

附着式起重机的拆卸与安装相反，若用户拆塔时没有完全把握，要参照安装顺序编写出拆塔说明，然后按顺序进行拆塔。

### 10.5.5 Assemble the attached strut

10.5.5.1 Adjust the length of the attached strut and lift up to the respective position, fixed both ends with tapered pins.

10.5.5.2 Examine the verticality by theodolite, and you can adjust the guide screw to insure the verticality within 4%.

10.5.5.3 Lock the nuts of both ends of the attached strut. It is all-important.

After the tower crane attached, you are required to examine the both ends of the attached strut and insure them are tight enough.

### 10.6 Dismantlement of attached tower crane

The dismantlement of attached tower crane is contrary to the steps of installing it. So when dismounting tower crane, please conduct the steps according to the Instructions strictly.

附表一 各部润滑表

序号	润滑部位名称	润滑点数	润滑油种类	润滑方法
1	起升机构制动器	全部铰点	机油	每工作 56 小时用油壶加油
2	起升机构变速箱 小车牵引机构减速箱	3	冬季: HJ-20 机械油 夏季: HJ-30 机械油	每工作 240 小时适当加油, 1500 小时换油一次
3	所有滚动轴承 (除电机内轴承)		ZGIII 钙基润滑脂	每工作 160 小时适当加油, 每半年清除一次
4	全部电机轴承		冬季: ZG-II 钙基润滑脂 夏季: ZG-V 钙基润滑脂	每工作 1500 小时换油一次
5	全部钢丝绳		石墨润滑脂	每大、中修时油煮
6	全部滑轮		冬季: ZG-II 钙基润滑脂 夏季: ZG-V 钙基润滑脂	每工作 240 小时加油一次
7	回转机构减速器	3	N150 或 N220 齿轮油	每工作 240 小时加油一次, 1500 小时换油一次
8	回转机构开式齿轮, 外齿圈上、下坐圈跑道	10	冬季: II 号钙基脂 夏季: V 号钙基脂	每工作 56 小时涂抹和压注一次
9	液压油箱	1	L-HM46 液压油	每半年换油一次
10	回转液力耦合器	1	6 号液压油或 22 号汽轮机油	每工作 1500 小时换油一次
11	起升机构液压推杆器	2	L-HM46 液压油	半年换油一次

No.	Name of lubricating part	The lubrication point	Lubrication oil type	Lubrication way (hour)
1	The brake of hoisting mechanism	All the articulation points	Machine oil	Use the oil pot to add oil after working 56 hours
2	The adjustable speed transmission of hoisting mechanism, speed reducer box of trolley travel mechanism	3	In winter: HJ-20 In summer: HJ-30	Add oil properly after working 240 hours; change the oil one time after working 1500 hours.
3	All the rolling bearings (except the bearing in the electric machine)		ZGIII Albany greasy	Add oil properly after working 160 hours; clear one time every half-year
4	All the electric machine bearings		In winter: ZG- II In summer: G- V	Change oil one time after working 1500 hours
5	All the cable wires		Graphite oil	Oil boiling when make heavy repair and medium repair
6	All the pulleys (including the pulleys on the tower top)		In winter: ZG- II In summer: G- V	Add oil one time after working 240 hours
7	The planetary speed reducer of slewing mechanism	3	Gear oil of N50 or N220	Add oil one time after working 240 hours; change oil one time after working 1500 hours

8	The open gear of slewing mechanism, the upper and bottom part of external tooth, sit ring runway	10	In winter: ZG- II In summer: G- V	Daub, press and pour one time after working 56 hours
9	Hydraulic oil tank	1	Hydraulic oil of L-HM46	Every half-year
10	Slewing hydraulic coupler	1	#6 hydraulic oil or #22 turbine oil	Change oil one time after working 1500 hours
11	Hydraulic pushrod of hoisting mechanism	2	Hydraulic oil of L-HM46	Every half-year

附表二

外购件型号明细表

Appendix 2

Outsourced Parts list

机构名称 Mechanism Name	名称 Part name	型号 Type
起升机构 Lifting mechanism	电动机 Motor	YZP2 250M1-4B 30L 55kW
回转机构 Slewing mechanism	电动机 Motor	YTRVFW132M2-4F1 7.5kW YTRVFW132M2-4F2 7.5kW
	回转支承 Slewing bearing	011.50.1600
牵引机构 Traction mechanism	电动机 Motor	YTDVF132M1-4C 5.5kW
顶升机构 Jacking mechanism	液压系统 Hydraulic system	顶升液压系统总成THS11011Z00401 (液压泵站型号: THS11011Z00401-00, 油缸型号 G18551091F)
起重量限制器 Lifting weight limiter	起重量限制器 Lifting weight limiter	BWL-12T-φ 490-PZ
力矩限制器 Moment limiter	力矩限制器 Moment limiter	BWL-D5A-Z

附表三 随机用图

Appendix 3 Attached drawings

序号 No.	名 称 Name		图 号 Drawing code	份数 QTY	备 注 Remark
1	平衡重 Counter weight	平衡重 A Counterweight A 平衡重 B Counterweight B 平衡重 C Counterweight C		1 1 1	用户按需自备 Unser-made
2	固定基 础 Fixed base	固定基础图 Fixed base figure	H15A	1	用户自备 Unser-made
3	电气部 分 Electric part	电气原理图 Electric diagram		1	用户用于检修 For inspection and repair

## 验收试验

### 验收试验--首次安装

型号：\_\_\_\_\_ 编号：\_\_\_\_\_ 试验人：\_\_\_\_\_

载荷+10%动态试验

#### 1. 最大幅度

载荷：\_\_\_\_\_ +10%=\_\_\_\_\_ Kg 卷扬机速度：\_\_\_\_\_ m/min

所进行动作	记录
起升	
回转	
变幅	
行走	

#### 2. 中间幅度

载荷：\_\_\_\_\_ +10%=\_\_\_\_\_ Kg 卷扬机速度：\_\_\_\_\_ m/min

所进行动作	记录
起升	
回转	
变幅	
行走	

载荷+25%静态试验

载荷：\_\_\_\_\_ +25%=\_\_\_\_\_ Kg 幅度：\_\_\_\_\_ m

记录：\_\_\_\_\_

安全试验装置

#### 1. 起重量限制器和力矩限制器

最大幅度：\_\_\_\_\_ m 卷扬机高度吊载：\_\_\_\_\_ Kg

接触器在\_\_\_\_\_ Kg 载荷时动作

中间幅度：\_\_\_\_\_ m 卷扬机高度吊载：\_\_\_\_\_ Kg

接触器在\_\_\_\_\_ Kg 载荷时动作

小车运行：载荷\_\_\_\_\_ Kg 在\_\_\_\_\_ m 处吊起

小车运行到\_\_\_\_\_ m 幅度时接触器动作

#### 2. 起升吊钩高度限位器 卷扬机高速

记录：\_\_\_\_\_



## 验收试验

### 验收试验--首次安装

型号：\_\_\_\_\_ 编号：\_\_\_\_\_ 试验人：\_\_\_\_\_

载荷+10%动态试验

#### 1. 最大幅度

载荷：\_\_\_\_\_ +10%=\_\_\_\_\_ Kg 卷扬机速度：\_\_\_\_\_ m/min

所进行动作	记录
起升	
回转	
变幅	
行走	

#### 2. 中间幅度

载荷：\_\_\_\_\_ +10%=\_\_\_\_\_ Kg 卷扬机速度：\_\_\_\_\_ m/min

所进行动作	记录
起升	
回转	
变幅	
行走	

载荷+25%静态试验

载荷：\_\_\_\_\_ +25%=\_\_\_\_\_ Kg 幅度：\_\_\_\_\_ m

记录：\_\_\_\_\_

安全试验装置

#### 1. 起重量限制器和力矩限制器

最大幅度：\_\_\_\_\_ m 卷扬机高度吊载：\_\_\_\_\_ Kg

接触器在\_\_\_\_\_ Kg 载荷时动作

中间幅度：\_\_\_\_\_ m 卷扬机高度吊载：\_\_\_\_\_ Kg

接触器在\_\_\_\_\_ Kg 载荷时动作

小车运行：载荷\_\_\_\_\_ Kg 在\_\_\_\_\_ m 处吊起

小车运行到\_\_\_\_\_ m 幅度时接触器动作

#### 2. 起升吊钩高度限位器 卷扬机高速

记录：\_\_\_\_\_



## 验收试验

### 验收试验--首次安装

型号：\_\_\_\_\_ 编号：\_\_\_\_\_ 试验人：\_\_\_\_\_

载荷+10%动态试验

#### 1. 最大幅度

载荷：\_\_\_\_\_ +10%=\_\_\_\_\_ Kg 卷扬机速度：\_\_\_\_\_ m/min

所进行动作	记录
起升	
回转	
变幅	
行走	

#### 2. 中间幅度

载荷：\_\_\_\_\_ +10%=\_\_\_\_\_ Kg 卷扬机速度：\_\_\_\_\_ m/min

所进行动作	记录
起升	
回转	
变幅	
行走	

载荷+25%静态试验

载荷：\_\_\_\_\_ +25%=\_\_\_\_\_ Kg 幅度：\_\_\_\_\_ m

记录：\_\_\_\_\_

安全试验装置

#### 1. 起重量限制器和力矩限制器

最大幅度：\_\_\_\_\_ m 卷扬机高度吊载：\_\_\_\_\_ Kg

接触器在\_\_\_\_\_ Kg 载荷时动作

中间幅度：\_\_\_\_\_ m 卷扬机高度吊载：\_\_\_\_\_ Kg

接触器在\_\_\_\_\_ Kg 载荷时动作

小车运行：载荷\_\_\_\_\_ Kg 在\_\_\_\_\_ m 处吊起

小车运行到\_\_\_\_\_ m 幅度时接触器动作

#### 2. 起升吊钩高度限位器 卷扬机高速

记录：\_\_\_\_\_



## 验收试验

### 验收试验--首次安装

型号：\_\_\_\_\_ 编号：\_\_\_\_\_ 试验人：\_\_\_\_\_

载荷+10%动态试验

#### 1. 最大幅度

载荷：\_\_\_\_\_ +10%=\_\_\_\_\_ Kg 卷扬机速度：\_\_\_\_\_ m/min

所进行动作	记录
起升	
回转	
变幅	
行走	

#### 2. 中间幅度

载荷：\_\_\_\_\_ +10%=\_\_\_\_\_ Kg 卷扬机速度：\_\_\_\_\_ m/min

所进行动作	记录
起升	
回转	
变幅	
行走	

载荷+25%静态试验

载荷：\_\_\_\_\_ +25%=\_\_\_\_\_ Kg 幅度：\_\_\_\_\_ m

记录：\_\_\_\_\_

安全试验装置

#### 1. 起重量限制器和力矩限制器

最大幅度：\_\_\_\_\_ m 卷扬机高度吊载：\_\_\_\_\_ Kg

接触器在\_\_\_\_\_ Kg 载荷时动作

中间幅度：\_\_\_\_\_ m 卷扬机高度吊载：\_\_\_\_\_ Kg

接触器在\_\_\_\_\_ Kg 载荷时动作

小车运行：载荷\_\_\_\_\_ Kg 在\_\_\_\_\_ m 处吊起

小车运行到\_\_\_\_\_ m 幅度时接触器动作

#### 2. 起升吊钩高度限位器 卷扬机高速

记录：\_\_\_\_\_



## 塔机投入使用性能试验记录

塔机说明：型号 \_\_\_\_\_ 编号 \_\_\_\_\_

吊钩下高度（起升高度） \_\_\_\_\_ m

幅度： \_\_\_\_\_ m

工地： \_\_\_\_\_

签字人职务： \_\_\_\_\_

公司： \_\_\_\_\_

地址： \_\_\_\_\_

我承认上述编号的塔机：

- 随机附有使用说明书；
- 其安装符合制造厂的规定；
- 在上述工地安装后已进行合格试验；
- 外部带有主要性能的明显的标牌；
- 处于可工作状态；

上述试验不涉及塔机与地面的连接，这一连接由用户根据安装说明书的数据进行准备。

投入使用日期： \_\_\_\_\_

用户或代表

公司或试验人

签字

签字

---

本项《塔机投入使用性能试验记录》  
寄回徐工集团徐州建机工程机械有限公司

## 塔机投入使用性能试验记录

塔机说明：型号\_\_\_\_\_ 编号\_\_\_\_\_

吊钩下高度（起升高度）\_\_\_\_\_m

幅度：\_\_\_\_\_m

工地：\_\_\_\_\_

签字人职务：\_\_\_\_\_

公司：\_\_\_\_\_

地址：\_\_\_\_\_

我承认上述编号的塔机：

- 随机附有使用说明书；
- 其安装符合制造厂的规定；
- 在上述工地安装后已进行合格试验；
- 外部带有主要性能的明显的标牌；
- 处于可工作状态；

上述试验不涉及塔机与地面的连接，这一连接由用户根据安装说明书的数据进行准备。

投入使用日期：\_\_\_\_\_

用户或代表

公司或试验人

签字

签字

---

本项《塔机投入使用性能试验记录》由销售商保存

## 验收试验

---

## 塔机投入使用性能试验记录

塔机说明：型号 \_\_\_\_\_ 编号 \_\_\_\_\_

吊钩下高度（起升高度） \_\_\_\_\_ m

幅度： \_\_\_\_\_ m

工地： \_\_\_\_\_

签字人职务： \_\_\_\_\_

公司： \_\_\_\_\_

地址： \_\_\_\_\_

我承认上述编号的塔机：

- 随机附有使用说明书；
- 其安装符合制造厂的规定；
- 在上述工地安装后已进行合格试验；
- 外部带有主要性能的明显的标牌；
- 处于可工作状态；

上述试验不涉及塔机与地面的连接，这一连接由用户根据安装说明书的数据进行准备。

投入使用日期： \_\_\_\_\_

用户或代表

公司或试验人

签字

签字

---

本项《塔机投入使用性能试验记录》由用户留存

## 验收试验

---

## 塔机投入使用性能试验记录

塔机说明：型号 \_\_\_\_\_ 编号 \_\_\_\_\_

吊钩下高度（起升高度） \_\_\_\_\_ m

幅度： \_\_\_\_\_ m

工地： \_\_\_\_\_

签字人职务： \_\_\_\_\_

公司： \_\_\_\_\_

地址： \_\_\_\_\_

我承认上述编号的塔机：

- 随机附有使用说明书；
- 其安装符合制造厂的规定；
- 在上述工地安装后已进行合格试验；
- 外部带有主要性能的明显的标牌；
- 处于可工作状态；

上述试验不涉及塔机与地面的连接，这一连接由用户根据安装说明书的数据进行准备。

投入使用日期： \_\_\_\_\_

用户或代表

公司或试验人

签字

签字

---

本项《塔机投入使用性能试验记录》保留在本说明书内

## 验收试验

---

### 性能试验条件

验收试验应由专业人员或由塔机制造厂商指定的机构或其合法代表进行。

#### 一、试验条件

1. 目测检查压重：数量和位置；
2. 载荷试验时，风速不得超过 10m/s(36 公里/小时)；
3. 载荷试验是将自由悬挂在吊钩上的载荷吊起。

#### 二、动态试验

1. 不必进行塔机组合动作，每一动作将分别试验；
2. 进行各种试验时，应按操作说明操作塔机；
3. 如果各项功能合格并经目检未发现机构和结构件有任何损坏，则试验为合格。

#### 三、静态试验

1. 该试验为将相应的载荷吊离地面 100mm 至 200mm，保持不动至少 10 分钟；
2. 如未发现任何影响塔机安全性能裂纹、永久变形或其他损坏、则试验为合格。

## 验收试验

---

# 验收试验

维修日期	维修内容	备注	维修人姓名职务	维修人所属单位部门	维修人签名

# 验收试验

维修日期	维修内容	备注	维修人姓名职务	维修人所属单位部门	维修人签

## 验收试验

维修日期	维修内容	备注	维修人姓名职务	维修人所属单位部	维修人签名

